



# Decommissioning plan for Wind Turbine A02 in Nysted Offshore Wind Farm

**Prepared** Gundula Fischer (GUNFI)  
Rasmus Hauberg Møller (RAMOL)

**Accepted** Gundula Fischer (GUNFI)

**Approved** Rasmus Hauberg Møller (RAMOL)

Doc. No. 07673566\_A  
Doc. Date 30 March 2022

# Table of Contents

1	Background and application.....	3
2	Description of the offshore wind farm.....	3
2.1	Location of the wind farm .....	3
2.2	Location of wind turbine A02.....	4
2.3	Wind turbine generator.....	6
2.4	Foundation .....	7
3	Decommissioning plan .....	9
3.1	Scope and timing of the work.....	9
3.2	Removal of WTG and recycling .....	10
3.3	Foundation removal including cable parts.....	12
4	Seabed survey .....	12
5	Annex.....	13
5.1	Appendix 1: Application Form .....	13

## 1 Background and application

Nysted Offshore Windfarm at Rødsand built in 2003 and comprising 72 wind turbine generators (WTGs) with a total capacity on 166MW have unfortunately on the 12<sup>th</sup> of January 2022 experienced a collapse of WTG and foundation A02.

Ørsted who owns and operates the offshore windfarm is with this application intending to recover the foundation and WTG.

This document describes how the collapsed A02 WTG and foundation will be removed, and possibly recycled.

Due to the limited scope of the decommissioning operation, no independent assessment of the environmental impacts of this project has been prepared. The application form indicating if any potential impact on the environment is to be expected has been completed and is attached to this decommissioning plan.

## 2 Description of the offshore wind farm

### 2.1 Location of the wind farm

Nysted Offshore Wind Farm at Rødsand is located approx. 10 kilometres south of Nysted and about 13 kilometres from Gedser in the waters south of Lolland, see Figure 1. It is operated from the port of Nysted.



Figure 1: Location of Nysted Offshore Windfarm

The wind farm consists of 72 wind turbines in eight rows with each 9 turbines and is connected by internal cables laid out in straight lines between the wind turbines. An export cable connects the wind farm to the onshore grid. The water depth in the wind farm varies between 5 and 15 meters.

## 2.2 Location of wind turbine A02

The collapsed turbine was standing at position A02, see Figure 2.



Figure 2: Nysted OWF layout and location of collapsed WTG

The coordinate for the wind turbine A02 is shown in Table 1 below.

WTG ID	HUB HEIGHT	WGS84_LAT	WGS84_LON	WGS84_UTM31_X	WGS84_UTM31_Y
A02	70	54,5651791	11,66726777	672440,98	6049678,06

Table 1: Coordinate for wind turbine position A02

The distance between Nysted's turbine A02 to the nearest protected habitat is approx. 754,65 m from 1 x Type A and 1 x Type B protected habitat sites.



Neighbouring protected habitats are:

- Type A – Special Protection Area (SPA), Birds Directive Site - [Kyststrækningen v. Hyllekrog-Rødsand](#)
- Type B – Special Area of Conservation (SAC), Habitats Directive Site - [Smålandsfarvandet nord for Lolland, Guldborg Sund, Bøtø Nor, Hyllekrog-Rødsand](#)



Figure 3: Location of Nysted Wind Farm and protected habitats

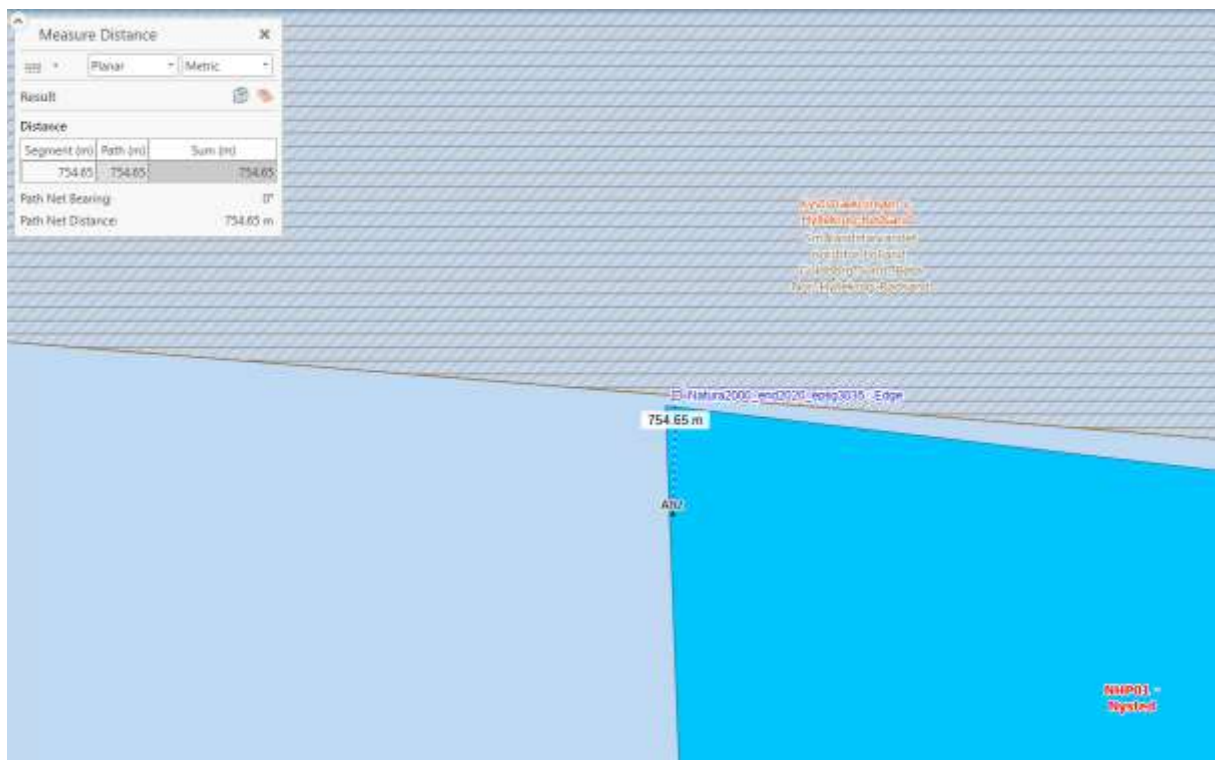

Figure 4: Distance WTG A02 to protected habitats

### 2.3 Wind turbine generator

The wind farm consists of SGRE-2.3-82 wind turbines. A drawing of the turbine is shown in Figure 5. Dimensions and weight of the Nysted A02 wind turbine are shown in Table 2.

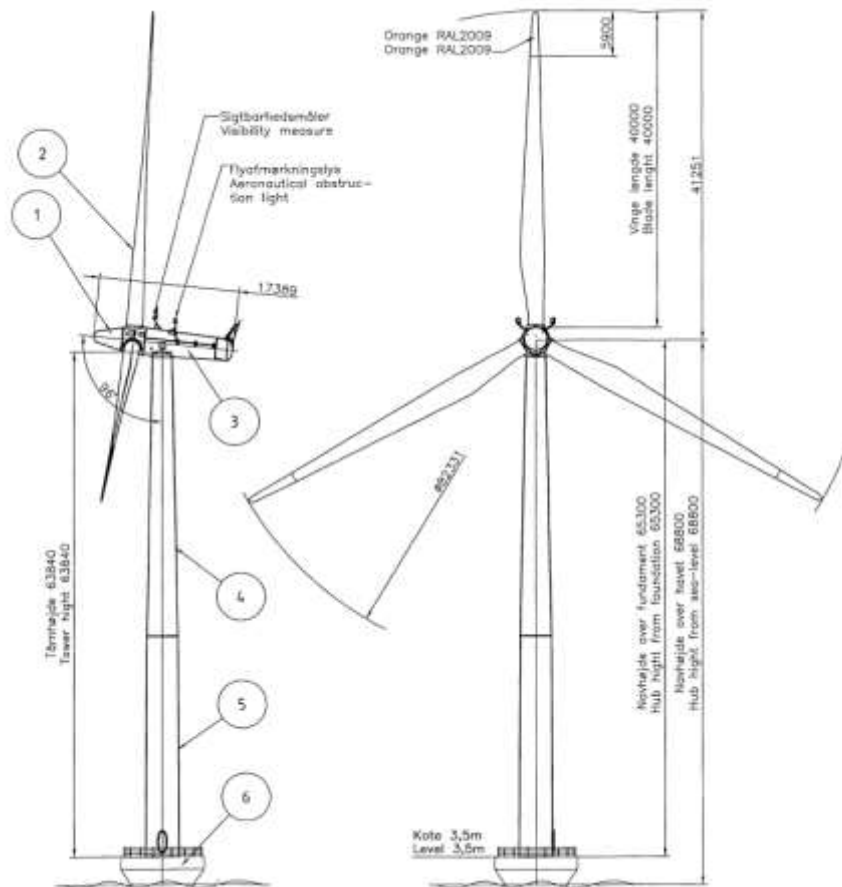

Figure 5: Overview of Nysted turbine

Weights on selected components	
Nacelle	82.100 kg
Blades	27.600 kg
Hub	26.400 kg
Generator	7.000 kg
Gear	23.400 kg
Main shaft incl. bearings	16.000 kg
Power unit	7.300 kg
Tower	121.000 kg

Table 2: Weights of main components.

## 2.4 Foundation

The wind turbines are placed on gravitation foundations cast in concrete; cone-shaped concrete benches that stand on the seabed and protrude above the sea surface. Before the foundations were lowered into positions, as much as 10 meters had been dug through the seabed to reach 'solid ground'. Then a cushion (gravel pit) of stone was laid out and straightened with millimetre precision to ensure that the bottom was completely horizontal. Below sea level, the foundation is built as a large heavy baseplate with a hexagonal, open box above. This ballast box is filled up with stones to ensure that the foundation is heavy enough to support the WTG.

Drawings showing the technical principle of the foundation and gravel pit are shown in Figure 6, Figure 7 and Figure 8. This gives an overall idea of dimensions. Weights on main components and parts can be seen in Table 3. **Error! Reference source not found.**

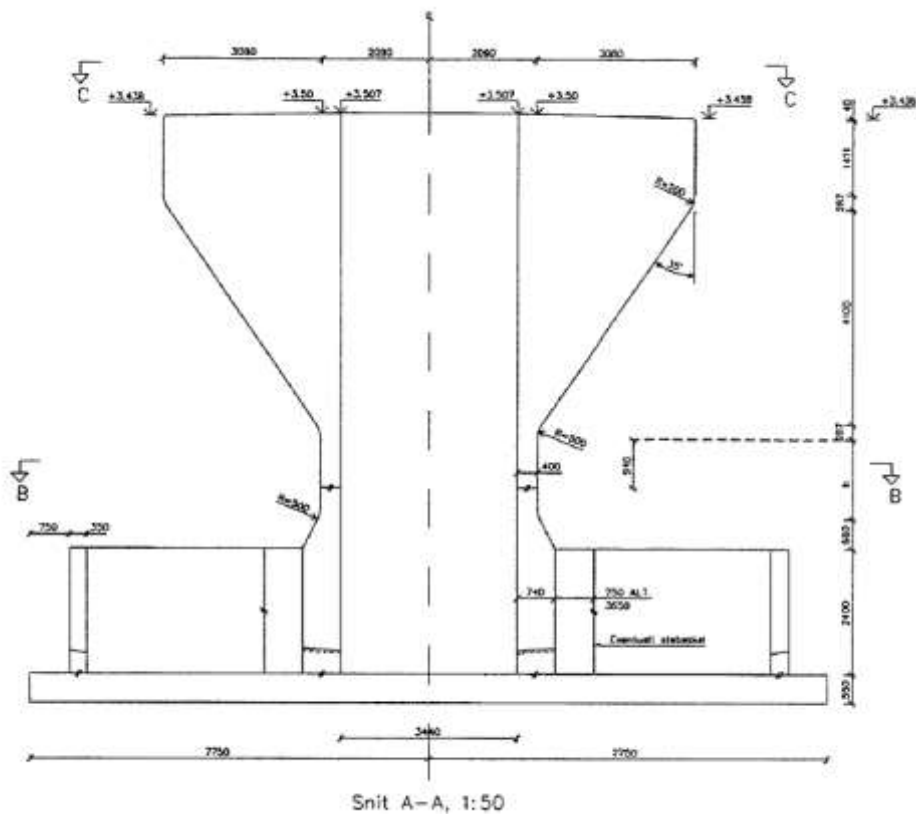

Figure 6: Drawing showing side view of foundation.





Dimensions, weights and volumes of the foundation and the ballast material are listed in Table 3.

Dimensions, weights and volumes on selected parts and components	
Total height	13,00 m
Total with	15,50 m
Foundation volume (concrete)	512 m <sup>3</sup>
Total weight (concrete)	695 t
Ballast volume total	419 m <sup>3</sup>
Ballast weight total	944 t
Gravel volume	1.695 m <sup>3</sup>
Gravel weight total	3801 t

**Table 3: Dimensions, weights and volumes on selected parts and components**

### 3 Decommissioning plan

Ørsted is in the process of selecting a contractor for the removal of A02 responsible for the execution of the project, as described below. Ørsted has not entered into a contract yet, thus the contractor has not yet prepared detailed risk assessments and method statements for decommissioning and removal of each individual component of the wind turbine. This will take place before the work is initiated and in cooperation with Ørsted and may lead to minor adjustments to the decommissioning methods described below, including, for example, workflows or equipment used. If, contrary to expectations, significant changes are decided that could be of importance regarding environmental impacts of the project, the Danish Energy Agency will be notified immediately.

#### 3.1 Scope and timing of the work

Overall, the overall removal project comprises the following activities:

- Mobilisation of vessels, divers and equipment
- Cutting the ice cone
- Lifting and bringing tower to port
- Lifting and bringing ice cone, hub, nacelle and blades to port
- Removing ballast material from bottom part of foundation with excavator
- Lift bottom part of foundation
- Cut cables running to A01 and A03
- Bring bottom part of foundation, ballast material and cable parts to port
- Conduct as left survey
- Dismantling yard at receiving port

Wind turbines, foundations and cables are transported from the wind farm to the receiving port where the recycling process will begin.

It is expected that the removal can be done during June 2022.

### 3.2 Removal of WTG and recycling

The collapsed WTG A02 is from the current knowledge broken into several pieces as it can be seen in Figure 9 and Figure 10. Therefore, the process of removal will be to first cut with a diamond wire the connected top part of the foundation, see Figure 11. This will leave the dark blue part of the foundation connected with the tower which will be lifted and brought to the receiving port.

Nacelle, hub and blades will be lifted and brought to the receiving port together with the two other sections in Figure 11, coloured light blue and grey.

Additional precautionary measures for environmental protection, such as the use of floating booms around the salvage site of the turbine to contain and collect any leaked oil, will be agreed with the Danish Energy Agency prior to the decommissioning operation.

When the parts are in the receiving port, the process of recycling the various wind turbine components will be started. Components will not be reused due to the condition but will be recycled by a certified recycling company (e.g. Stena Recycling A/S or H.J. Hansen A/S) in accordance with Danish law. As Ørsted has announced that no blades will be put in landfills, this is not an option.

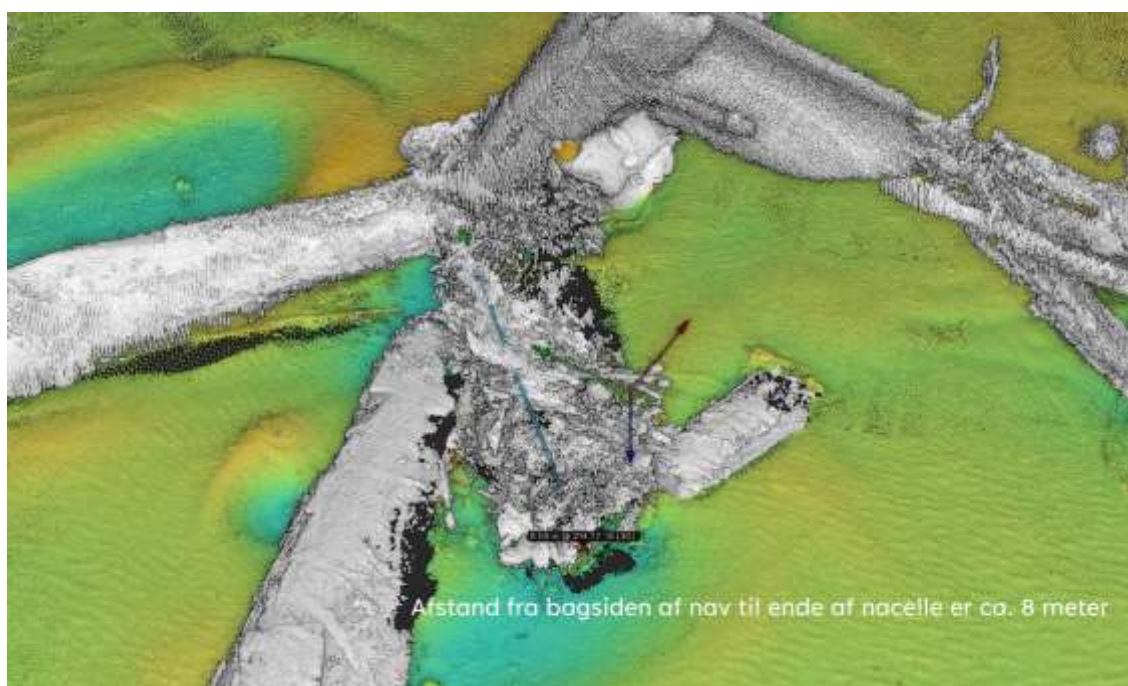

**Figure 9: Survey picture - Nacelle**

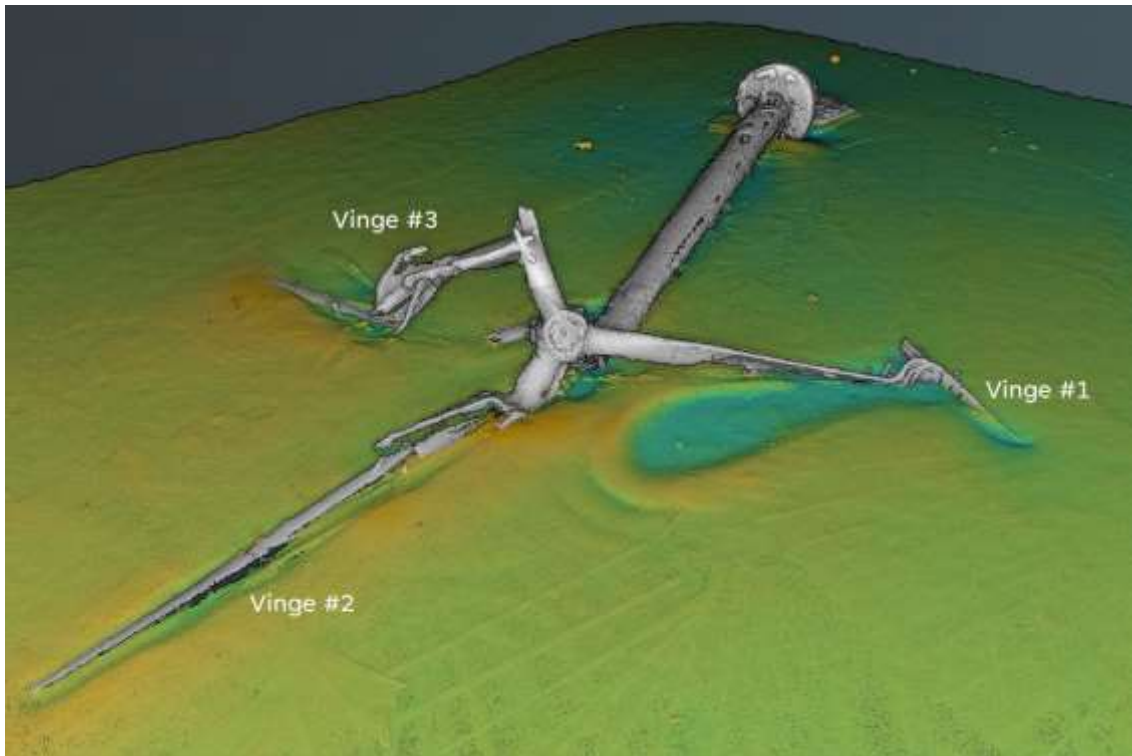

Figure 10: Survey picture – Entire WTG

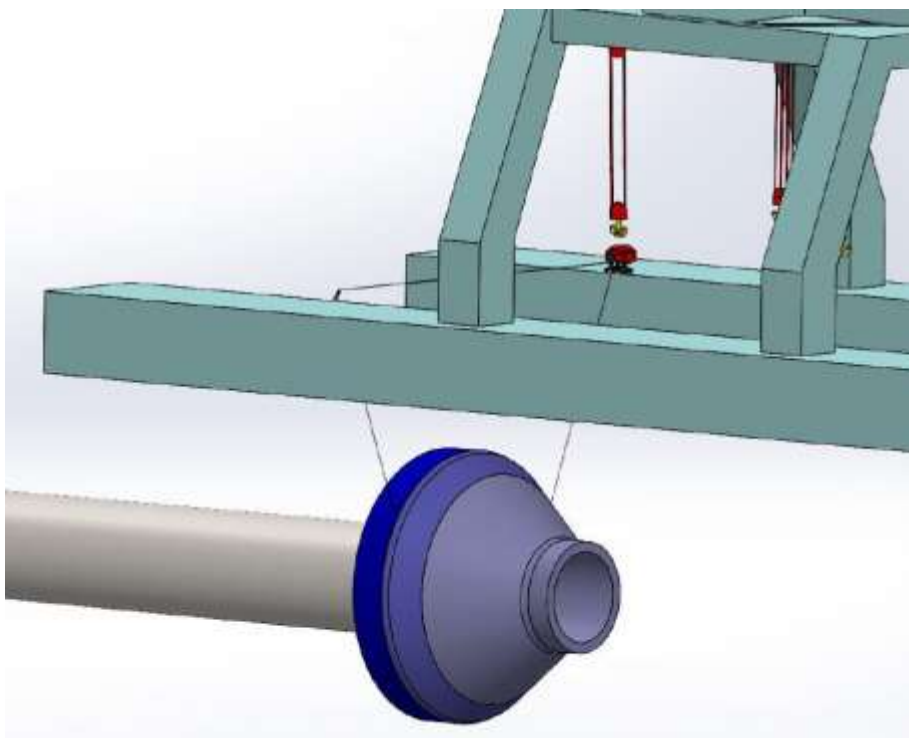
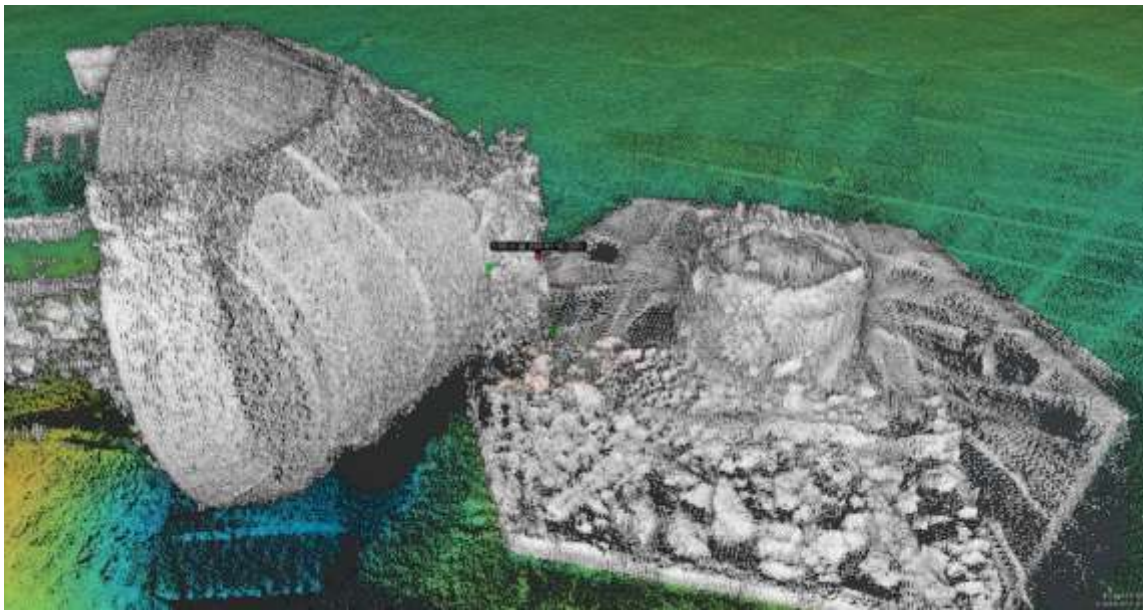

Figure 11: Cutting of ice cone

### 3.3 Foundation removal including cable parts

As described in the previous section, the top part (ice cone) of the foundation will be cut and removed together with the WTG parts. When these parts are removed, what is left will be the bottom part of the foundation seen to the right in Figure 12.



**Figure 12: Survey picture - Foundation**

In the bottom part of the foundation six ballast chambers will be emptied for rocks by means of an excavator which will be taken to the receiving port and then the bottom part will be lifted and taken to port as well.

When in port the foundation will be broken into small pieces and recycled.

The array cables for A02, one going to A01 and one going to A03, will be cut close to the A02 foundation. Loose parts will be taken to shore and recycled. This will leave the majority of the cables between A02 and A01, A03 in the seabed until the rest of the windfarm is being decommissioned. The intention is to make the cable cuts below the seabed so nothing is resting on the seabed.

What is not removed is the gravel pad underneath the foundation. The gravel pad is already below seabed and will be completely covered by the seabed quickly when the foundation is removed.

## 4 Seabed survey

At the end of the decommissioning work, a survey of the seabed will be carried out to document that all material from the foundation and turbine has been removed and the area has been recycled in accordance with the agreement with the Danish Energy Agency.

## 5 Annex

All appendices have been submitted as separate documents to the decommissioning plan.

### 5.1 Appendix 1: EIA-screening application form

Document: ansøgningskema - application form EN - Decommissioning NHP A02 (07680916\_A)