



# Commercial maritime freight- and passenger transport

---

Technology descriptions and projections  
for long-term energy system planning.



## Technology data – Commercial maritime freight- and passenger transport

ISBN 978-87-94447-12-6

First published in January 2024 the Danish Energy Agency

Current version published by:

Danish Energy Agency

Carsten Niebuhrs Gade 43

1577 Copenhagen

E-mail: [teknologikatalog@ens.dk](mailto:teknologikatalog@ens.dk),

Internet: <https://ens.dk/technologydata>

Design and production: Danish Energy Agency

Front cover photo: Adobe Stock

Version number: 0002

This work is licensed under [Attribution 4.0 International](https://creativecommons.org/licenses/by/4.0/) 

## Amendment sheet

### Publication date

Publication date for this catalogue “Technology Data – Commercial freight- and passenger transport” is January 2024. In April 2024 this amendment sheet has been added and also the possibility to add descriptions of amendments in the individual chapters if required. Hereby the catalogue can be updated continuously as technologies evolve, if the data changes significantly or if errors are found.

The newest version of the catalogue will always be available from the Danish Energy Agency’s website.

### Amendments after publication date

All updates made after the publication date will be listed in the amendment sheet below.

Version	Date	Ref.	Description
0001	January 2024	Datasheets	Datasheets adjusted and removed from the technology catalogue. Datasheets in xlsx format remain available on the website.
0002	April 2024	Cover	New cover

## Preface

The purpose of this report is to provide a comprehensive overview of key transport technologies within the maritime transport sector. Technology catalogues published by the Danish Energy Agency aims to establish a standardized and up-to-date basis for planning activities, including evaluations of environmental impacts, technical and economic analyses, and assessments of framework conditions for the development and deployment of specific classes of technologies. It should be noted that this report does not aim to provide an exhaustive collection of specifications on all available incarnations of transport technologies. Instead, selected, representative technologies are included to enable generic comparisons of technologies with similar functions in the transport system. Updates to this report will be made as technologies evolve, significant data changes occur, or errors are found. Any updates will be listed in the amendment sheet on and in connection with the relevant chapters. The most recent version of this report will be available on the Danish Energy Agency’s website. Finally, this report is intended for both Danish and international audiences and aims to contribute to similar initiatives aimed at forming a public and concerted knowledge base for international analyses.

## Danish preface

Formålet med denne rapport er at give et indblik i centrale transportteknologier inden for maritim transport. Teknologikataloger udgivet af Energistyrelsen har til formål at etablere et standardiseret og opdateret grundlag for

planlægningsarbejde og vurderinger af forsyningsikkerhed, beredskab, miljø og markedsudvikling hos bl.a. de systemansvarlige selskaber, universiteterne, rådgivere og Energistyrelsen. Dette omfatter for eksempel fremskrivninger, scenarieanalyser og teknisk-økonomiske analyser. Det skal bemærkes, at denne rapport ikke har til formål at give en udtømmende samling af specifikationer for alle tilgængelige maritime transportteknologier. I stedet indgår udvalgte, repræsentative teknologier for at muliggøre generiske sammenligninger af teknologier med lignende funktioner i transportsystemet. Opdateringer til denne rapport vil blive foretaget i takt med, at teknologier udvikler sig, der sker væsentlige dataændringer, eller der bliver fundet fejl. Eventuelle opdateringer vil blive anført i ændringsarket. Den seneste version af denne rapport vil være tilgængelig på Energistyrelsens hjemmeside. Endelig henvender denne rapport sig til både dansk og internationalt publikum og har til formål at bidrage til lignende initiativer, der har til formål at danne et offentligt og fælles vidensgrundlag for internationale analyser.

## Table of contents

<i>Amendment sheet</i> .....	3
<i>Preface</i> .....	3
<i>Danish preface</i> .....	3
<b>1. Introduction</b> .....	<b>7</b>
1.1. <i>Qualitative description</i> .....	9
1.2. <i>Quantitative description</i> .....	12
<i>Technical parameters</i> .....	14
<i>Environment</i> .....	15
<i>Financial data</i> .....	15
<b>2. Qualitative description – conventional diesel propulsion</b> .....	<b>16</b>
2.1. <i>Container ships</i> .....	28
2.2. <i>Bulk carriers and tankers</i> .....	31
2.3. <i>Ro-Ro cargo ferries</i> .....	34
2.4. <i>Ro-Ro passenger ferries</i> .....	36
2.5. <i>Fast ferries</i> .....	38
2.6. <i>Small ferries</i> .....	40
<b>3. Qualitative description – methanol internal combustion engine</b> .....	<b>41</b>
3.1. <i>Container ships</i> .....	47
3.2. <i>Bulk carriers and tankers</i> .....	47
3.3. <i>Ro-Ro cargo ferries</i> .....	48
3.4. <i>Ro-Ro passenger ferries</i> .....	48
3.5. <i>Fast ferries</i> .....	48
3.6. <i>Small ferries</i> .....	48
<b>4. Qualitative description – internal combustion engine with ammonia</b> .....	<b>49</b>
4.1. <i>Container ships</i> .....	52
4.2. <i>Bulk carriers and tankers</i> .....	53

4.3.	<i>Ro-Ro cargo ferries</i> .....	53
<b>5.</b>	<b>Qualitative description – battery electric propulsion</b> .....	<b>53</b>
5.1.	<i>Ro-Ro cargo ferries</i> .....	59
5.2.	<i>Fast ferries</i> .....	60
5.3.	<i>Small ferries</i> .....	60
<b>6.</b>	<b>Qualitative description – fuel cell propulsion</b> .....	<b>61</b>
6.1.	<i>Small ferries</i> .....	64
<b>7.</b>	<b>Quantitative description</b> .....	<b>65</b>
7.1.	<i>Documentation of central assumptions behind the data sheets</i> .....	65
7.2.	<i>Technical parameters</i> .....	66
7.3.	<i>Energy and fuel related parameters</i> .....	88
7.4.	<i>Environment and climate</i> .....	91
7.5.	<i>Financial data</i> .....	93
<b>8.</b>	<b>References</b> .....	<b>100</b>

## 1. Introduction

This introduction acts as a guideline defining the disposition for the content of the technology catalogue. This is based on similar principles used in the chapters for trucks and buses available on the website of the Danish Energy Agency.

This catalogue presents technologies applying to seaborne transport. Ships have a high degree of diversity, which is why a set of standard ship types are selected to provide a generalized overview of the technical parameters.

The primary purpose of the catalogue is to provide generalized data that can be applied in analyses of ships in the transport sector, including economic scenario models and high-level transport planning. The focus of the catalogue is limited to providing data for the technological performance of the ships. Consequently, the catalogue does not provide data or detailed information on fuel prices, upstream emissions associated with fuel production, or costs and externalities linked to the necessary infrastructure.

Each technology is described in a separate technology chapter, making up the main part of the catalogue. The catalogue will focus on technologies involving electric propulsion systems and internal combustion engines powered by alternative fuels such as ammonia and methanol. It is, however, the intention that the catalogue can be extended with additional chapters and technologies when relevant. It is not the intent of the catalogue to choose or recommend any specific technology, but strictly to provide descriptions alongside data for use in further analyses and modelling of the transport sector.

The catalogue also includes a chapter on the conventional Internal Combustion Engines (ICE) with marine oil-based fuel, which serves as the baseline to which new alternative engine technologies and fuels are compared. Each technology is described in relation to propulsion system, typical fuel/energy consumption, emissions, and cost parameters where possible. The technology chapters in the catalogue contain a qualitative description of the technologies. Quantitative data are published in a separate Excel file for Data sheets. All aspects and data within the catalogue are related to new ships. The qualitative and quantitative descriptions below explain the formats of the technology chapters, how data are obtained, and the underlying assumptions.

The different propulsion technologies and fuels in this catalogue are the following:

- Internal combustion engine with conventional marine fuel
- Internal combustion engine with methanol
- Internal combustion engine with ammonia
- Electric motor with batteries as storage technology
- Electric motor with fuel cells using hydrogen

To undertake meaningful analysis of technologies in maritime transport, the heterogeneous shipping sector is broken down into 6 categories. The ship types selected for each category and segment are generic types representing typical ship configurations for each segment. Apart from container ships, bulk carriers, and tankers there is a diverse segment of ferries. Roll-on/Roll-off (Ro-Ro) vessels are cargo ships designed to carry wheeled cargo such as cars, trucks, buses, etc. Some Ro-Ro ferries have a larger focus of passenger transport. The differences will be described in the technology chapters.

The ship types included are the following:

- Container ships in two main categories:
  - Smaller container feeder ships
  - Larger container ships
- Bulk carriers and tankers are in the same category, as they share similar design characteristics and structure

- Ro-Ro cargo ferries
- Ro-Ro passenger ferries
- High-speed car carrying catamaran ferries
- Small ferries

Not all propulsion technologies or fuels are investigated for all ship types, which is illustrated in Table 1 and will be elaborated in the individual technology chapters. The selection and prioritization are based on the maturity of the technology in combination with ship type. In future updates of the catalogue, the combination of technologies and ship types can be expanded.

Marine gas oil (MGO)/marine diesel oil (MDO), in combination with diesel engines, is chosen as the baseline technology for all the ships. The difference between MGO and MDO is outlined in chapter 2, however, the energy content and emission factors are very similar, and the results from model calculations are very similar. Another fuel type, heavy fuel oil (HFO), is primarily used for container ships, bulk carriers and tankers used together with a SO<sub>x</sub> scrubber to comply with emission limits for sulphur, if the actual sulphur content in the HFO is too high. With the scrubber technology, emissions from HFO are similar to MGO/MDO. Overall, the differences between the fuels are smaller than the uncertainties of the emission factors, which is why the same baseline fuels are used across all ship types.

Alternative energy storage technologies, such as flywheels, might prove relevant for electric propulsion systems in the future. However, these technologies are still immature within the shipping sector, which makes data more speculative. The technologies can be added in future versions of the catalogue. Similarly, fuel cells operating on ammonia or methanol can be included in updates of the catalogue, if deemed relevant.

The technologies included in this catalogue are stated in the table below.

**Table 1 Overview of ship types and propulsion technologies and fuels provided in this catalogue**

	MGO /MDO	Battery electric	Fuel cells	Methanol	Ammonia
Container feeder ships	✓	✗	✗	✓	✓
Larger container ships	✓	✗	✗	✓	✓
Bulk carriers / tankers	✓	✗	✗	✓	✓
Ro-Ro cargo ferries	✓	✓	✗	✓	✓
Ro-Ro passenger ferries	✓	✓	✗	✓	✗
High-speed catamaran ferries	✓	(✓)	✗	✓	✗
Small ferries	✓	✓	(✓)	✓	✗

✓ = Qualitative description + datasheets available

✗ = Not included

(✓) = Qualitative description available



## 1.1. Qualitative description

The qualitative description describes the key characteristics of the technology as concise as possible. The following paragraphs are included where relevant for the technology.

### Contact information

Containing the following information:

- Contact information: Contact details in case the reader has clarifying questions to the technology chapters. This could be the Danish Energy Agency or the author of the technology chapters.
- Author: Entity/person responsible for preparing the technology chapters
- Reviewer: Entity/person responsible for reviewing the technology chapters.

### Description of propulsion technology and fuel

Presentation of the propulsion technology for non-engineers. A picture of a representative ship as well as a basic diagram of the propulsion technology should be included. In this qualitative section the technology description should include the normal service speed and maximum ship deadweight and payload of the technology, and the expected development in these parameters. For container ships it might also be relevant to add the full load container capacity and for ferries the cargo carrying capacity such as personal cars and/or lane meters for the rolling cargo units.

This section should also contain a description of the expected most relevant applications in Denmark based on current operations and routes. This qualitative consideration could include which ship types are relevant and examples of which sailing routes they service.

It should be noted, that in the quantitative parts of the catalogue and in the coherent datasheets, the technologies should be evaluated for the following propulsion technologies/fuels and ship types:

- Internal combustion engine with conventional marine fuel
- Internal combustion engine with methanol
- Internal combustion engine with ammonia
- Electric motor with batteries as storage technology
- Electric motor with fuel cells using hydrogen

The included ship types are the following:

- Container ships in two main categories:
  - Smaller container feeder ships
  - Larger container ships
- Bulk carriers and tankers, which are very similar and will be put in the same category.
- Ro-Ro cargo ferries
- Ro-Ro passenger ferries
- High-speed car carrying catamaran ferries
- Small ferries

### *Advantages/disadvantages*

A description of specific advantages and disadvantages relative to the other propulsion technologies.

### *Bunkering or charging infrastructure*

A description of the bunkering or charging facilities should provide an overview of the current status (i.e. potential for bunkering e-fuels or charging infrastructure in ports), prospects for development going forward (i.e. through policy requirements for alternative energy infrastructure in ports and announced Danish PtX (Power-to-X) projects with a maritime focus), and potential benefits and/or challenges relative to other propulsion technologies.

### *Interaction with the energy system*

Briefly reflect on how the propulsion technology and/or the fuel utilised interacts with the Danish energy system. I.e., how rapid charging of ferries may strain the distribution network in some areas.

### *Current market and technological status and future development perspectives*

A presentation of the current market and technology status, and expectations for the future. This section should include the most relevant challenges to further development of the propulsion technology/fuel. The potential for technological development in terms of costs and efficiency should be quantified in the data sheets.

The status and developments in neighbouring countries shall also be discussed (i.e., possibilities for bunkering e-fuels or charging infrastructure).

### *Environment and climate*

The environmental footprints associated with ships arise largely during their use and via their production and scrapping.

This section should therefore include a description of the energy use, technological filters/emission reduction technologies utilised, and resulting “tailpipe” or *local emissions*<sup>1</sup> released during use of the specific propulsion system. Local emissions include CO<sub>2</sub>, CH<sub>4</sub>, NO<sub>x</sub>, N<sub>2</sub>O, SO<sub>x</sub>, CO<sub>2</sub>, HC<sub>3</sub> and particulate emissions per nautical mile.

In addition, the section can mention a description of where the future ships are likely to be built.

### *Prediction of performance and costs*

Cost reductions and performance improvements can be expected for most technologies in the future. This section describes the assumptions underlying the cost and performance aspects in 2023 as well as the improvements assumed for the years 2025, 2030, 2040 and 2050.

The specific propulsion technology is identified and classified in one of four categories of technological maturity (see below), indicating the commercial and technological progress, and the assumptions for the projections are described in detail.

The potential for improving technologies is linked to the level of technological maturity. The technologies are categorised within one of the following four levels of technological maturity.

---

<sup>1</sup> The upstream emissions are not within the scope of this chapter, nor is it within the scope of this technology catalogue.

**Category 1.** Technologies that are still in the *research and development phase*. The uncertainty related to price and performance today and in the future is highly significant.

**Category 2.** Technologies in the *pioneer phase*. The technology has been proven to work through demonstration. Due to the limited application, the price and performance is still attached with high uncertainty, since development and customisation is still needed. The technology still has a significant development potential.

**Category 3.** *Commercial technologies with moderate deployment*. The price and performance of the technology today is well known. These technologies are deemed to have a certain development potential and therefore there is a considerable level of uncertainty related to future price and performance.

**Category 4.** *Commercial technologies, with large deployment*. The price and performance of the technology today is well known, and normally only incremental improvements would be expected. Therefore, the future price and performance may also be projected with a relatively high level of certainty.

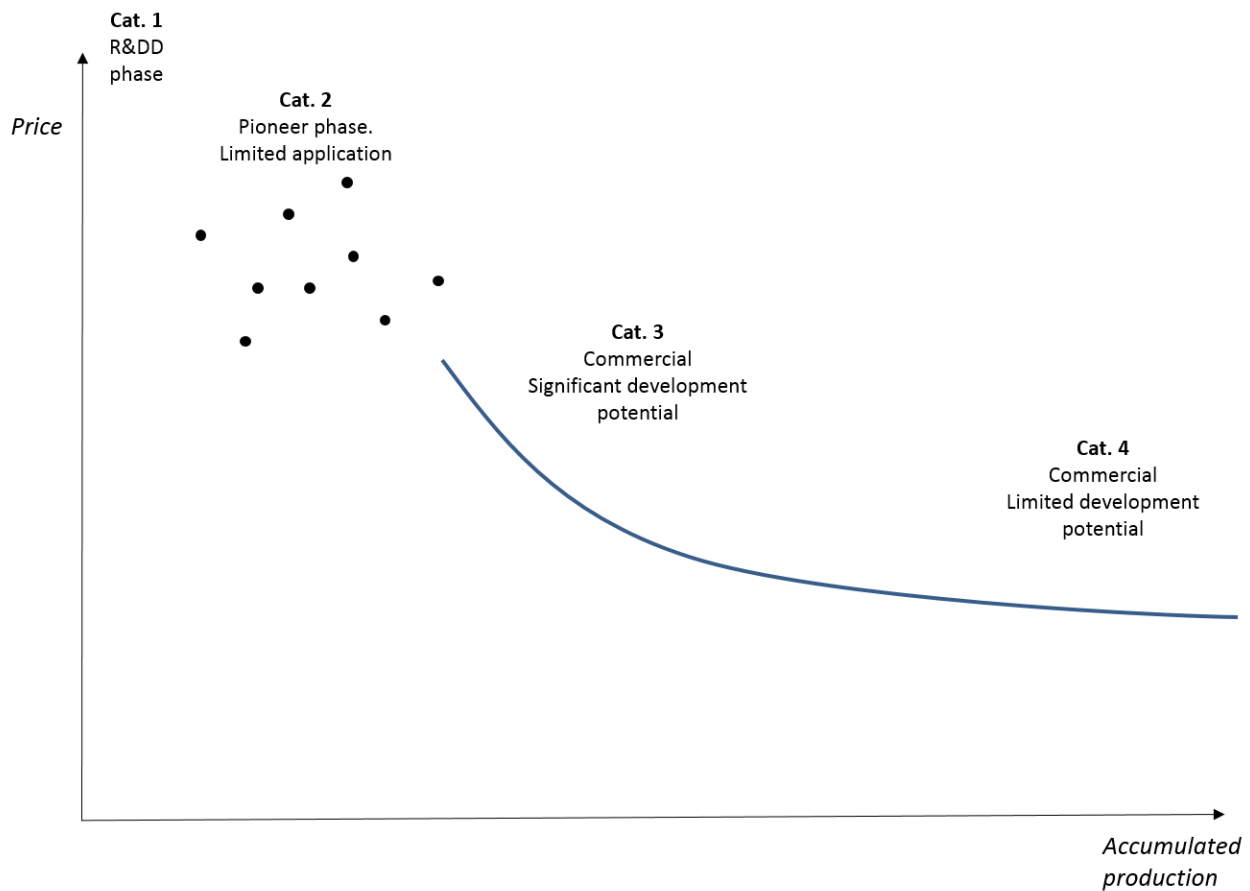

**Figure 1: Technological development phases. Correlation between accumulated production volume (MW) and price**

### Uncertainty

The catalogue covers both mature technologies and technologies under development. This implies that the price and performance of some technologies may be estimated with a relatively high level of certainty whereas in the case of others, both cost and performance today as well as in the future are associated with high levels of uncertainty.

This section of the technology chapters explains the main challenges to precision of the data and identifies the areas of uncertainty. This includes technological or market related issues of the specific technology as well as the level of experience and knowledge in the sector and possible limitations on raw materials. The issues should also relate to the technological development maturity as discussed above.

#### **Additional remarks**

This section includes other information, for example links to web sites that describe the technology further or give key figures on it.

## **1.2. Quantitative description**

To allow for comparison of different propulsion technologies and fuels, it is important that the data is presented in such a way that the utility of each set of combination of technology and ship type is as comparable as possible. For example, if the battery in an electric ferry results in the ship weighing more than a MGO version within the same category, the emissions and energy usage should be provided for a MGO and electric ferry with the same amount of payload.

A part of the table designed to contain all the required quantitative data is displayed below (Table 2). All data should refer to a new ship produced in the year indicated. All cost data should be stated in fixed 2023 prices excluding value added taxes (VAT) and other taxes.

Each cell should contain only one central numeric value (i.e., no range of values). To reflect a potential range of values, there are columns labelled “typical range”, providing a lower and higher bound representing the variation within a ship type/technology and are based on empirical data. Most of the technical data are not linked to actual uncertainty, and therefore it is more suitable to present a range of values representing the smaller and larger ships within a ship type. The section on uncertainty in the qualitative description for each technology indicates the main issues influencing the uncertainty related to the specific technology. For technologies in the early stages of technological development or technologies especially prone to variations of cost and performance data, the bounds expressing the confidence interval could result in large intervals. The level of uncertainty is not stated in the Data sheet, as the ranges reflect the variation within each ship category. This approach can be changed in future versions of the catalogue if relevant.

All data in the tables should be referenced by a number in the utmost right column (Ref), referring to source specifics below the table.

Notes can include additional information on how data was obtained, as well as assumptions and potential calculations behind the figures presented.

**Table 2 Extract of table – with key parameters**

<b>Fast ferry, diesel</b>		
	<b>2023</b>	<b>2050</b>
<b>Technical parameters</b>		
Deadweight (tons)	699	699
Maximum payload/number of passengers (# of TEU/ passengers/ PCU/ LM)	300	300
Maximum payload (tons)	559	559
Typical payload (tons)	419	419
Fuel tank or battery size (m <sup>3</sup> or MWh)	25	25
Weight of battery (tons)	N/A	N/A
Main engine power (kW)	33.525	33.525
Maximum service speed (knots)	40	40
Typical operational speed (knots)	36	36
Length (m)	97	97
Breadth (m)	27	27
Drought (m)	4	4
<b>Energy and fuel related parameters</b>		
Energy consumption - typical payload (GJ/nm)		
Typical operational speed	6,74	6,74
<b>Environment</b>		
Low speed – typical payload		
CO <sub>2</sub> emissions per nautical mile (kg/nm)	527,01	527,01
CH <sub>4</sub> emissions per nautical mile (kg/nm)	0,01	0,01
N <sub>2</sub> O emissions per nautical mile (kg/nm)	0,03	0,03
NO <sub>x</sub> emissions per nautical mile (kg/nm)	2,08	2,08
SO <sub>x</sub> emissions per nautical mile (kg/nm)	0,35	0,35
HC emissions per nautical mile (kg/nm)	0,43	0,43
CO emissions per nautical mile (kg/nm)	0,43	0,43
Particulates per nautical mile (kg/nm)	0,23	0,23
<b>Financial data</b>		
Typical ship lifetime (years)	30	30
Typical battery lifetime (years)	N/A	N/A
Upfront ship cost (mill. €)	63	63
Fixed O&M (€/year)	N/A	N/A
Variable O&M (€/nm)	N/A	N/A

## Technical parameters

### Deadweight (tonnes)

Deadweight tonnage is a measure of how much weight a ship can carry and is the sum of weights of cargo, fuel, provisions, ballast water, passengers, crew etc. For all ship types and propulsion system/fuel combinations the maximum deadweight in tonnes is reported. Very often cargo ships are associated with the so-called design deadweight, which is typical approx. 90 % of the maximum deadweight.

### Maximum payload/number of passengers

For all ship types and propulsion system/fuel combinations the payload is given in tonnes and is solely associated with the weight of the cargo. Additionally, for container ships the maximum number of TEU (twenty-foot equivalent unit of cargo containers) is given. For ferries, the maximum number of passengers/cars/lane-meters for rolling cargo are useful parameters characterising the physical properties of actual ship.

### Typical payload (tonnes)

For all ship types the typical payload in tonnes.

### Fuel tank and/or battery size

Size of the fuel tank (in m<sup>3</sup>), or capacity of a battery (in MWh). For batteries, it is the total battery capacity. For electric propulsion, normally only approximately 60 % (depth of discharge) of the electric energy in the batteries can be utilized during normal operation before recharging is necessary. This is based on lithium-ion batteries used in ships to date and depends on trade-offs between battery lifetime, charging speed and range.

### Battery weight

Only relevant for electric ships. Depends on the development of the energy density in batteries.

### Main engine power (kW)

The power of the propulsion engine(s) in a standard ship within the type (in kW).

### Maximum service speed

The maximum speed of the ship types and propulsion system/fuel combinations (in knots).

### Typical operational speed

The typical operational speed of the ship types and propulsion system/fuel combinations (in knots).

### Typical length

The typical length of the ship. The most used length is the length between perpendiculars, L<sub>pp</sub>, i.e. the length from the point where stem intersects the waterline (forward PP) to the rudder stock in the aft part of the ship, designated the aft perpendicular (AP). Sometimes the intersection between the stern and the waterline is defined as the aft perpendicular – in such a case L<sub>pp</sub> is equal to the waterline length. The waterline is corresponding to the deepest allowable draught for the ship.

### Typical breadth

The typical breadth of the ship is the so-called maximum waterline breadth.

### Typical draught

The typical draught of the ship is the maximum allowable draught.

## Energy and fuel related parameters

### Energy consumption

The energy consumption (GJ/nm) should ideally be based on examples of ships analysed with e.g. the SHIP-DESMO tool, which applies empirical and semi-empirical calculation methods. The results from these simulations could, if possible, also be summarised in a chart.

The values should be presented according to low, typical operational and maximum service speed as well as maximum, and typical payload.

## Environment

### Emissions

Local emissions of CO<sub>2</sub>, CH<sub>4</sub>, N<sub>2</sub>O, NO<sub>x</sub>, SO<sub>2</sub>, HC, CO and particulates in g/nm and g/t/nm (meaning per tonne payload) resulting from the operation of the ship for. The values should be presented according to low, typical operational and maximum service speed as well as maximum and typical payload.

Upstream emissions related to fuels are not included.

## Financial data

### Typical ship lifetime

Typical lifetime of the ship (in years)

### Typical battery lifetime

Typical lifetime of the battery (in years). Depends on assumptions on charging cycles etc.

### Upfront ship cost

The upfront cost of the typical vessel (in €). Cost of batteries /propulsion system should be presented separately, if possible. If a significant replacement part (i.e., a battery) is anticipated to be required before the end of the ship's typical lifetime, then the additional anticipated cost of that part in a future year could be indicated as a potential extra cost.

### Fixed O&M

The fixed operations and maintenance O&M costs (€/year), where possible.

### Variable O&M (€/nm)

The variable operations and maintenance O&M costs ((€/nm)), where possible.

## 2. Qualitative description – conventional diesel propulsion

### Contact information

Containing the following information:

- Contact information: The Danish Energy Agency, Ulrich Lopdrup, [ulo@ens.dk](mailto:ulo@ens.dk)
- Author: HOK Marineconsult ApS, Hans Otto Kristensen and COWI
- Reviewer: The Danish Energy Agency

### Description of propulsion technology and fuel

Different ship types use different propulsion systems that use several techniques for generating power. Conventionally, the required power is produced using one or more marine diesel engines that work on either two- or four-stroke mode. Strokes indicate the number of strokes of the piston to complete one operating cycle of the engine. These engines have several pistons/cylinders that generate rotational motion through the combustion of the fuel at ignition temperature. The rotational motion of the crank shaft is used to rotate the propeller(s) either directly (typical for slow speed two stroke engines) or via a gearbox for medium or high speed engines.

A more complex diesel-electric system uses diesel engines to power an electrical generator, which supplies electrical power to an electrical motor and other electrical consumers onboard.

For ship propulsion the following engine types are generally used:

- Low speed two-stroke diesel engines (50 – 300 RPM (revolutions per minute))
- Medium speed four-stroke diesel engines (300 – 1000 RPM)
- High speed four-stroke diesel engines (1000 – 3000 RPM)

### Diesel propulsion and power generation arrangements

The traditional propulsion and power generation arrangement for large deep sea commercial shipping has generally been a single slow-speed two-stroke main propulsion engine directly coupled to a fixed pitch propeller with typically three medium-speed four-stroke auxiliary engines driving generator sets (the number of auxiliary engines may in special cases vary between 2 and 5 engines). Two-stroke diesel engines have the highest efficiencies amongst mechanical means of propulsion, which is why they are used for ship types where fuel prices represent the main operating costs (e.g. container ships, bulk carriers and tankers).

The slow-speed two-stroke engine is typically defined as one with a rated speed of less than 300 RPM. It includes a long-stroke design as illustrated in Figure 2. The slow-speed design has evolved to ever larger piston strokes and bore-stroke



ratios (cylinder bore diameter / piston stroke length) in excess of 4.5 are now common. There has also been a trend for improved fuel consumption through increased brake mean effective pressure (BMEP). Typical BMEPs have risen from 18 to 22 bar and typical firing pressures increased from 140 to 180 bar since 2005. This has supported the trend in reducing rated engine speed and the use of ever larger diameter propellers for increased propulsion efficiency.

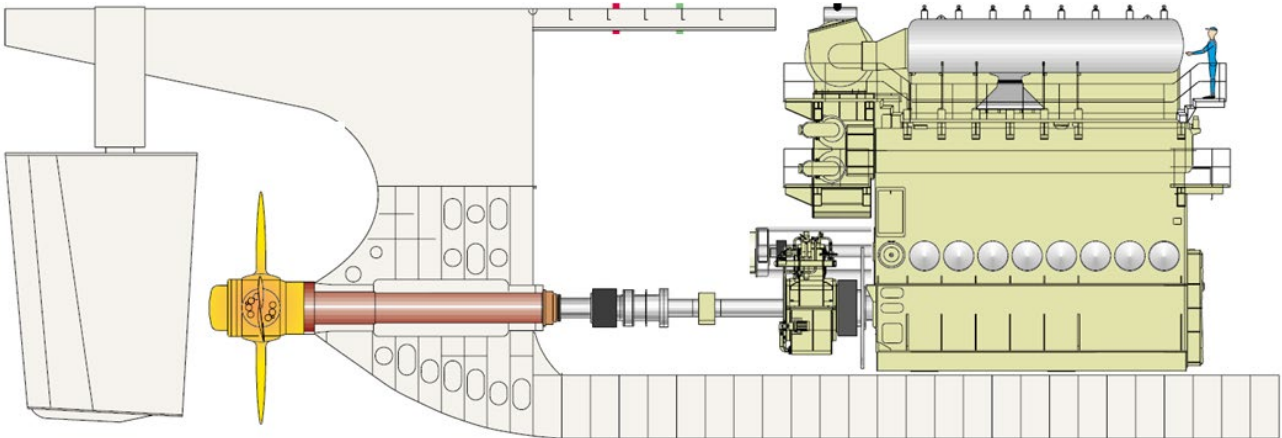

**Figure 2 Two-stroke engine installation with propeller (Courtesy MAN Energy Solutions)**

The medium-speed four-stroke diesel engines are defined as engines with a rated speed between 300 and 1000 rpm. These are used for propulsion and for power generation on deep sea fleets and usually have higher specific fuel oil consumption (SFOC) characteristics than the slow-speed two-strokes. An example of a typical main and auxiliary engine arrangement is shown in Figure 3. Medium-speed four-stroke engines also used as main propulsion with a gearbox on smaller ships.

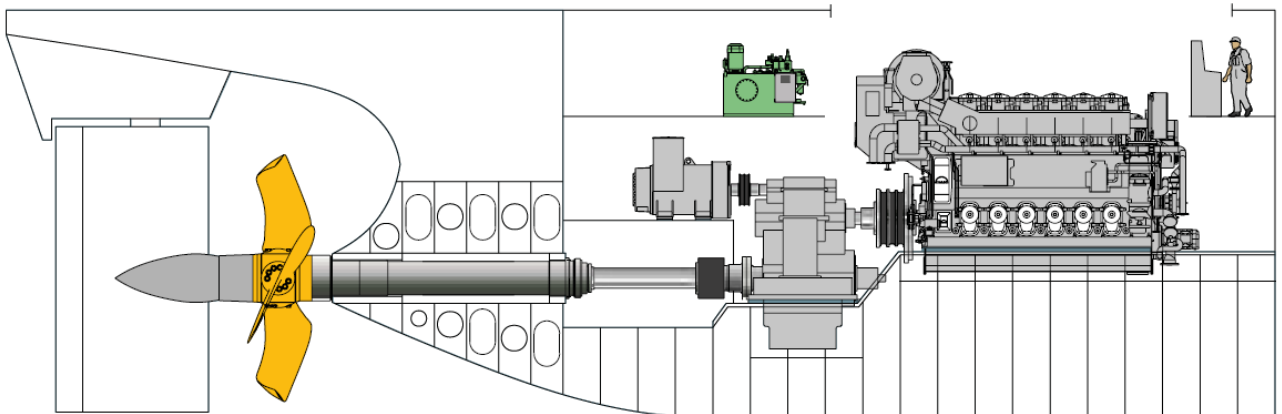
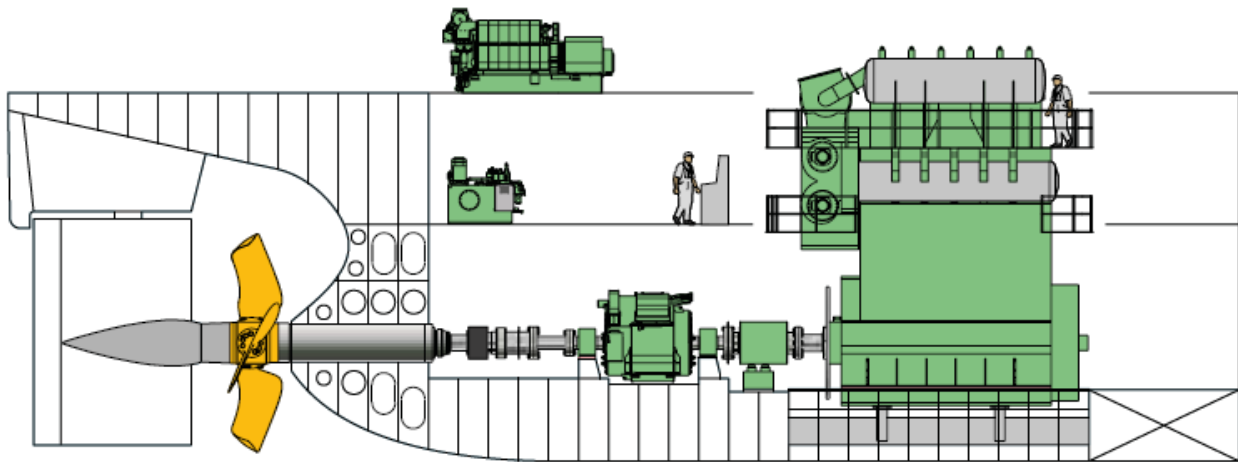

**Figure 3 Four-stroke medium speed propulsion system installation – complete powertrain with propeller (Courtesy MAN Energy Solutions)**

High-speed diesel engines are defined as engines with rated speeds over 1000 RPM. These may be utilized as auxiliary or emergency generator sets on larger vessels and as propulsion with a gearbox and auxiliary engines on smaller vessels such as ferries or patrol crafts where the high power to weight and power to volume metrics are a prerequisite.

### Diesel-electric propulsion

The main electrical power onboard ship is generated by the auxiliary diesel engine driven generators (by four-stroke engines), which may also be supplemented by a shaft generator driven from the two-stroke slow-speed main propulsion engine, as illustrated in Figure 4. Where engines are arranged in a diesel electric drive arrangement, the power generation engines provide power for both propulsion and ship electrical loads.



**Figure 4 Two-stroke main engine with an electric mechanical driven generator installed in the shaft line for generation of electrical power during normal sailing at sea (MAN Energy Solutions, 2023)**

Diesel electrical propulsion systems are often used on ships with a varying engine load profile, for example ferries, which must accelerate and decelerate during a crossing. The number of engines in operation can be varied according to the necessary power demand during an actual crossing scenario, where much power is needed in the acceleration phase. This means that each engine can be operated as close as possible to its optimum load (typically at 75 – 85 % of its maximum power). When less power is needed one or even more engines are completely stopped.

On the ferries on the route from Rødby to Puttgarden, diesel electric ferries, have been in operation since 1997. During the last decade the electric propulsion system has been gradually modified by installation of batteries, where batteries can be used for storage of the electric power generated<sup>2</sup>, when the propulsion power reaches a critical low load level, where the engines are running at a too low power level in a suboptimal situation. The excess electric power produced by the engines when they are kept running at a sufficiently high loading is fed into the batteries for later use. In this way the batteries make it possible to keep a very constant power level, such that the engine load is at an optimal level. This

---

<sup>2</sup> No external power is used to charge the onboard batteries.

together with completely new propellers has reduced the energy consumption per trip with 30 – 40 % over a period of approx. 20 years.

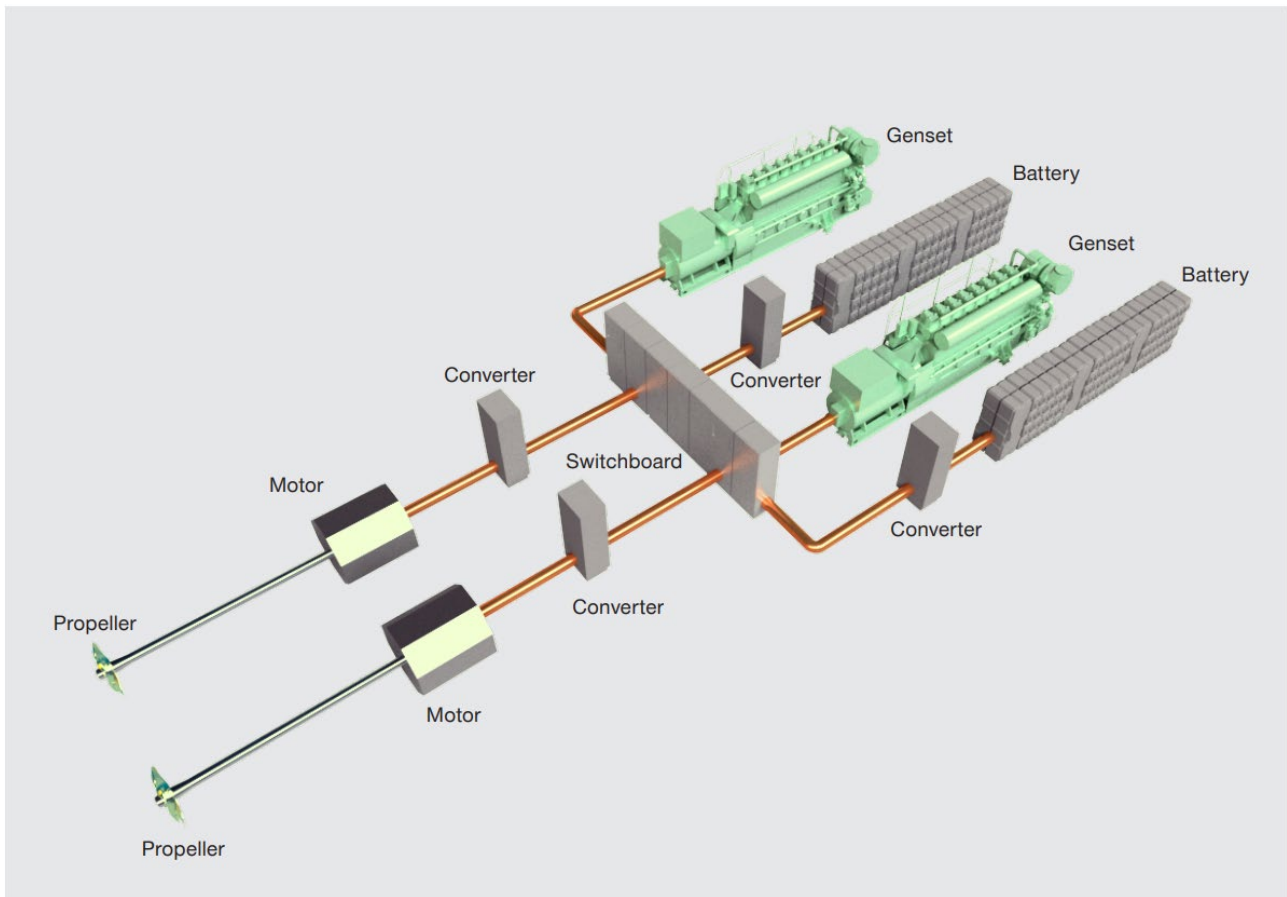

Figure 5 Combined diesel electrical and battery based propulsion system (MAN Energy Solutions, 2019)

### Propulsion via waterjet

For high-speed vessels so-called waterjets are often used instead of propellers as their efficiency in the high speed range is higher than the efficiency of conventional propellers. The size and arrangement of waterjets is also easier to install in a high-speed ship, as the machinery can be concentrated in the aft part of the hull structure, which is illustrated in Figure 6.

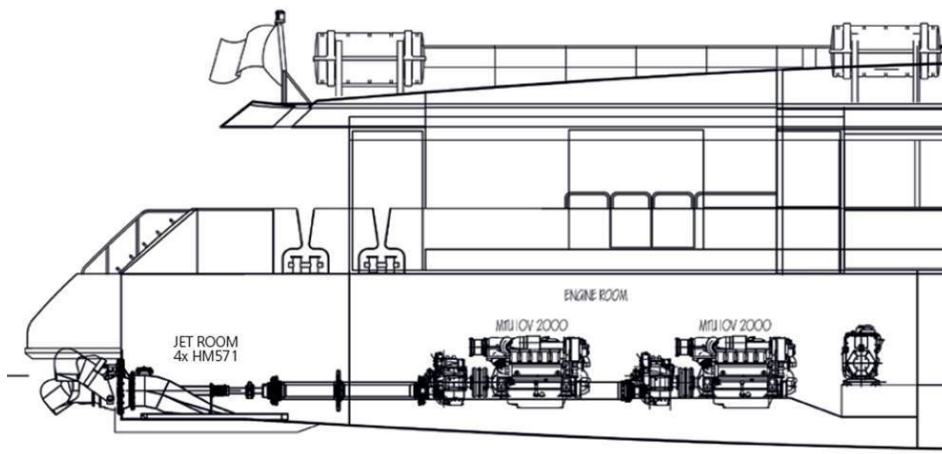

Figure 6 Drawing of a waterjet propulsion system with diesel engines (RINA, 2018)

### Advantages/disadvantages

ICE is a known technology with many variations adapted to the specific use. Spare parts, repair and maintenance are readily available. In addition, safety measures are well known.

The existing bunkering infrastructure is well established and provides the fuel globally.

MGO/MDO have a high energy density compared to other fuels and technologies at the current stage, which gives this technology a long range.

On the downside, diesel-oil emits greenhouse gases and air pollutants.

### Bunkering or charging infrastructure

Bunkering infrastructure is widely available worldwide.

### Interaction with the energy system

The use of diesel engines in shipping relies on fuel products from the refining process of crude oil. HFO Heavy Fuel Oil/bunker fuel oil) is a remnant from the distillations of crude oil, where MGO (Marine Gas Oil) is the refined more high-quality product and MDO (Marine Diesel Oil) is in the lower bracket of the refining process and therefore containing a small amount of HFO. The flashpoints and viscosity of the fuels are slightly different. MGO is typically used in smaller vessels such as ferries, due to the engine technology and emission regulations in the area of operation. MDO is used in a wide range of ships. HFO is predominantly used in large ocean-going vessels such as container ships, bulk carriers, and tankers, which have larger engines and higher fuel consumption, making HFO a cost-effective option. However, emission regulations have led to the usage of MGO/MDO or the installation of SO<sub>x</sub> scrubbers.

The continued use of fossil fuels in ships relies on the established supply chains and prices will be volatile along with changes to the general market demand within oil extraction. While the use of diesel engines as such increase demand for fossil fuel, they are not in direct relation to the energy system.

## Current market and technological status and future development perspectives

ICE using diesel is the most dominant form of propulsion technology today. However, to live up to greenhouse gas reduction goals in the future, a transition to other technologies and fuels with a lower or zero greenhouse gas impact will be needed.

Diesel-electric propulsion has emerged in especially ferries in the past 20 – 30 years. There can be advantages from diesel-electric propulsion for some segments, but it also leads to system energy losses. At present, no significant emerging trend away from direct-drive slow-speed propulsion systems for the bulk of the commercial deep sea fleet can be seen.

There is a general trend to minimise fuel consumption, also in the future, to reduce costs. Furthermore, requirements from regulators will contribute to the energy efficiency of new ships. An example is the Energy Efficiency Design Index (EEDI) developed by the International Maritime Organizations (IMO). The EEDI is used to calculate a vessel's energy efficiency. Regulations regarding EEDI thresholds apply for new ships commissioned and depend on the gross tonnage<sup>3</sup>, (GT), for ships larger than 400 GT and ship type. More ship types will be included in the future and the requirements are tightened over time as illustrated in Figure 7. EEDI rules for existing ships have also been introduced in recent years by IMO – however designated as EEXI (Energy Efficiency Existing Ship Index).

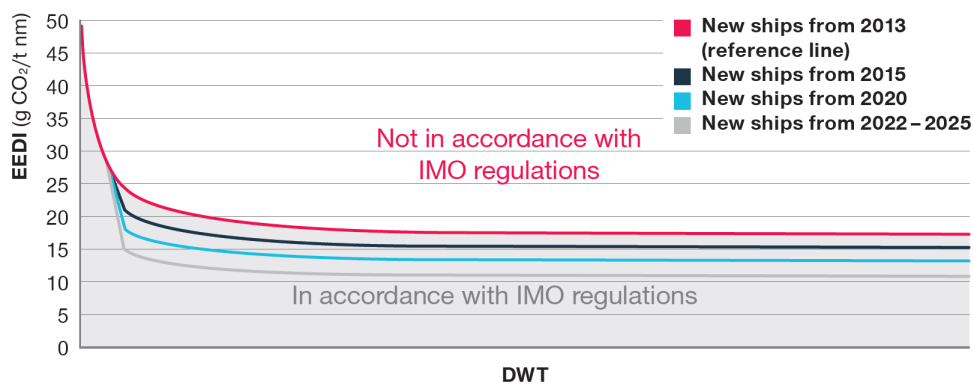

Figure 7 Principles of EEDI requirements (Courtesy MAN Energy Solutions)

## Environment and climate

### Specific fuel oil consumption (SFOC)

Exhaust emissions from marine diesel engines largely comprise of nitrogen, oxygen, carbon dioxide and water vapor with smaller quantities of carbon monoxide, oxides of sulphur and nitrogen, partially reacted and non-combusted hydrocarbons and particulate material. Emissions depend on the ship's energy consumption, i.e. the specific fuel oil consumption (SFOC)<sup>4</sup> and the emissions from the engines. The SFOC depends on the engine type:

<sup>3</sup> The gross tonnage refers to the internal volume of the ship. 1GT = 2.83m<sup>3</sup> (100 cubic feet) while deadweight tonnage refers to the ships carrying capacity measured in tones.

<sup>4</sup> Specific fuel oil consumption (SFOC) can be defined as fuel consumption in grams for unit power developed in unit time, SFOC is usually measured in g/kWh.

- The slow-speed two-stroke engine is the most efficient primary propulsion available and can achieve fuel efficiency in excess of 52 % from the base engine. This compares, for example, to an efficiency of approximately 42 % from an advanced road car diesel engine. With minimal losses from the direct-coupled engine to propeller configuration, the two-stroke slow-speed propulsion arrangement, particularly with a fixed pitch propeller (FPP), provides the simplest and most fuel-efficient propulsion option.
- Medium-speed two-stroke diesel engines have higher SFOC, typically approximately 10 % higher than a two-stroke slow-speed design at similar power levels.
- Similarly, high-speed four-stroke engines may have SFOC levels of approximately 10 % higher than the medium-speed designs.

Since the propulsion shaft speed of medium and high-speed engines needs to be reduced significantly to match an efficient propeller speed, these engines must be connected to the propeller through a speed reduction transmission system. This can be either through a mechanical reduction gear unit or an electric drive system. These transmission systems introduce additional losses, approximately 3 – 5 % from gear units and up to about 10 % from an electric drive system. Hence there can be significant fuel penalties for medium- and high-speed installations compared to slow speed.

The efficiency of diesel engines has continuously increased since the first maritime diesel engine was introduced on an ocean-going merchant ship, the *SELANDIA*, in 1912. This development is illustrated in Figure 8 for 2-stroke engines, where the oil crisis in 1973 intensified the positive development towards more efficient diesel engines. After 2000 the energy efficiency increase became more moderate, because of new regulations for lower NO<sub>x</sub> emissions, which slightly counteracted the positive development as most of the NO<sub>x</sub> reducing measures offset possible fuel oil savings. The average SFOC in 2023 is approx. 160 g/kWh, which can be slightly lower for the very large 2-stroke diesel engines and slightly higher for smaller diesel engines. The SFC figures corresponds to the use of MDO/MGO.

It was possible to decrease the specific fuel oil consumption even more than the general trend since 1973 as example by de-rating of a diesel-engine, where the engine is operated at its normal maximum cylinder pressure for the design continuous service rating, but at a lower mean effective pressure and shaft speed. However, today the difference to the general energy efficiency is not highly significant.

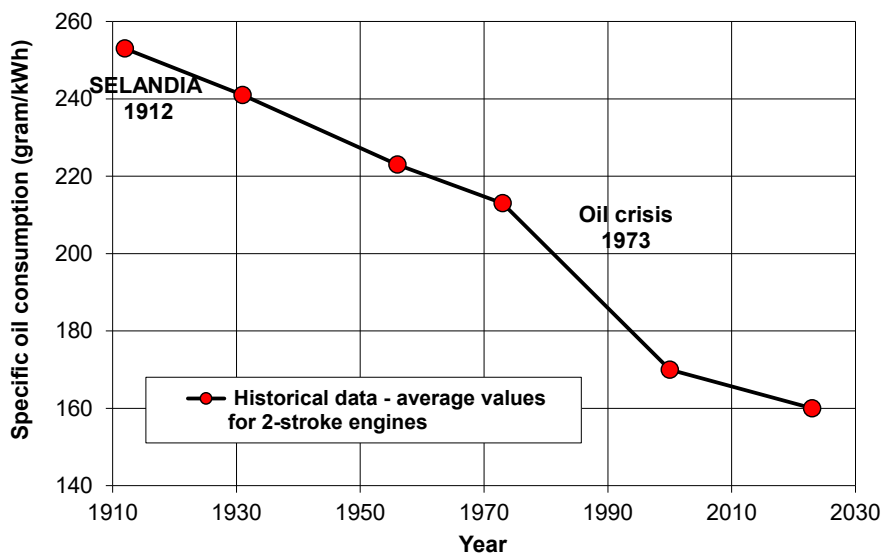

Figure 8 Development of specific oil consumption for two stroke low speed diesel engines (test bed conditions, 42.7 MJ/kg oil)

**SO<sub>2</sub> (SO<sub>x</sub>)**

SO<sub>2</sub> is proportional with the fuel oil consumption and the content of sulphur in the oil (see section 7.4). The lower the sulphur content is, the lower fuel specific emission rate of SO<sub>2</sub>. Consequently, more and more strict requirements towards lower sulphur content are imposed on oil for marine diesel engines have been introduced in recent years and will be tightened even further in the coming years. Concerns regarding pollution is likely to mean that heavy fuel oils with a sulphur content below the current average (of more than 1 -2%) will become more common in the years ahead, as forthcoming legislation restricts emission limits of both SO<sub>x</sub> and NO<sub>x</sub>.

The Baltic Sea and the North Sea are now ECA areas (Emission Control Areas) with a sulphur limit of 1 % in 2010 and further reduced to 0.1 % in 2020, as shown in Figure 9.

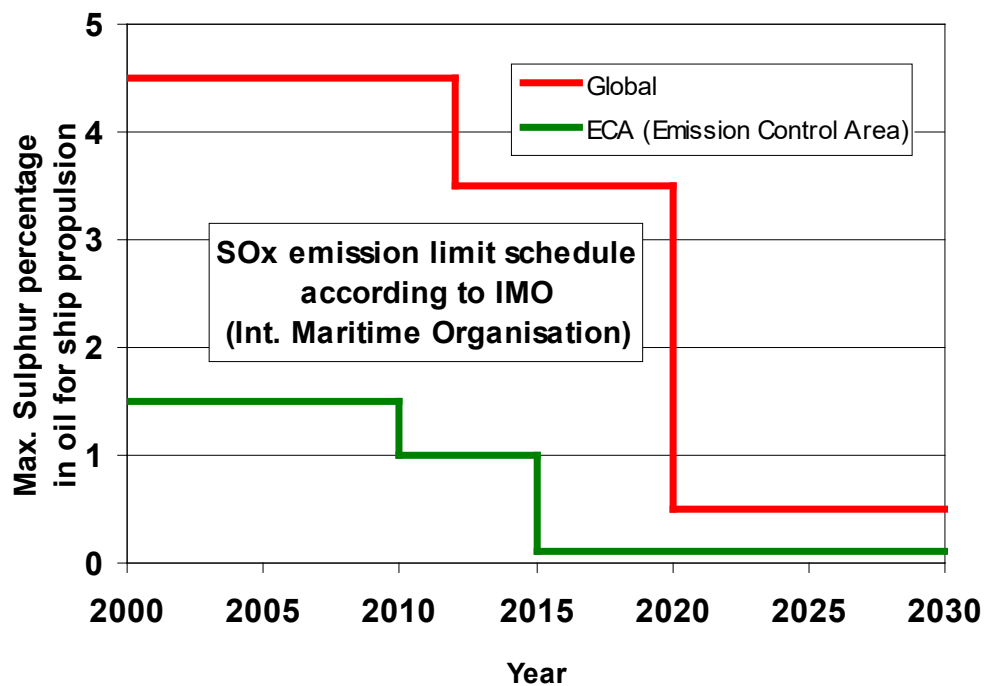

Figure 9 Maximum allowable sulphur content according to IMO legislation, MARPOL Annex VI

**SO<sub>2</sub> emission reduction technologies**

SO<sub>2</sub> emissions can be reduced either by using fuels with low sulphur content, which makes the fuel more expensive. An alternative solution is to use so-called scrubbers, which can be used for washing the exhaust gas from the main engine,

and in principle it can be compared to a large shower cabinet placed in the funnel of a ship. It is possible to reduce the sulphur emissions by 98 %, i.e. to a level as low as if low sulphur fuel oil<sup>5</sup> was used, while at the same time reducing particulate emissions by 40-75%.

## **NO<sub>x</sub>**

The fuel specific NO<sub>x</sub> emission rate for diesel engines depends on different factors e.g. the engine type. Slow speed engines have generally higher NO<sub>x</sub> emissions compared with medium speed engines, which is reflected in the requirements already imposed by IMO in the MARPOL Annex VI: *“Regulations for the Prevention of Air Pollution from Ships”*. NO<sub>x</sub> demands came into force in May 2005, with the clause that all diesel engines manufactured after January 2000 must fulfil the NO<sub>x</sub> demands, as shown in Figure 10.

The highest allowable specific NO<sub>x</sub> emission rate (IMO Tier I level for engines manufactured before 2011) is 17 g NO<sub>x</sub> per kWh for low-speed engines, while the rate for medium speed engines (750 RPM) is approximately 12 g NO<sub>x</sub>/kWh. For high-speed engines at about 1100 RPM the allowable NO<sub>x</sub> emission rate according to Tier I is approximately 11 g/kWh. Stricter limits under Tier II (since 2011) and III (since 2016) levels must be fulfilled corresponding to 20 % and 80 % NO<sub>x</sub> reduction respectively, compared with Tier I level, as shown in Figure 10. Stricter limits under Tier II (since 2011) and III (since 2016) levels must be fulfilled corresponding to 20 % and 80 % NO<sub>x</sub> reduction respectively, compared with Tier I level, as shown in Figure 10. Tier III standards only apply to specified ships operating in emission control areas and has been in effect since 2016 in the North American and Caribbean ECAs and 2021 in the Baltic Sea and North Sea ECAs.

---

<sup>5</sup> Fuel oils like Very Low Sulphur Fuel Oil (VLSFO) and Ultra-low Sulphur Fuel Oil (ULSFO) used as compliant fuels are not specifically analysed in this catalogue. Their energy content and CO<sub>2</sub>- emissions are close to MGO/MDO, however, other emissions like particulates are higher.



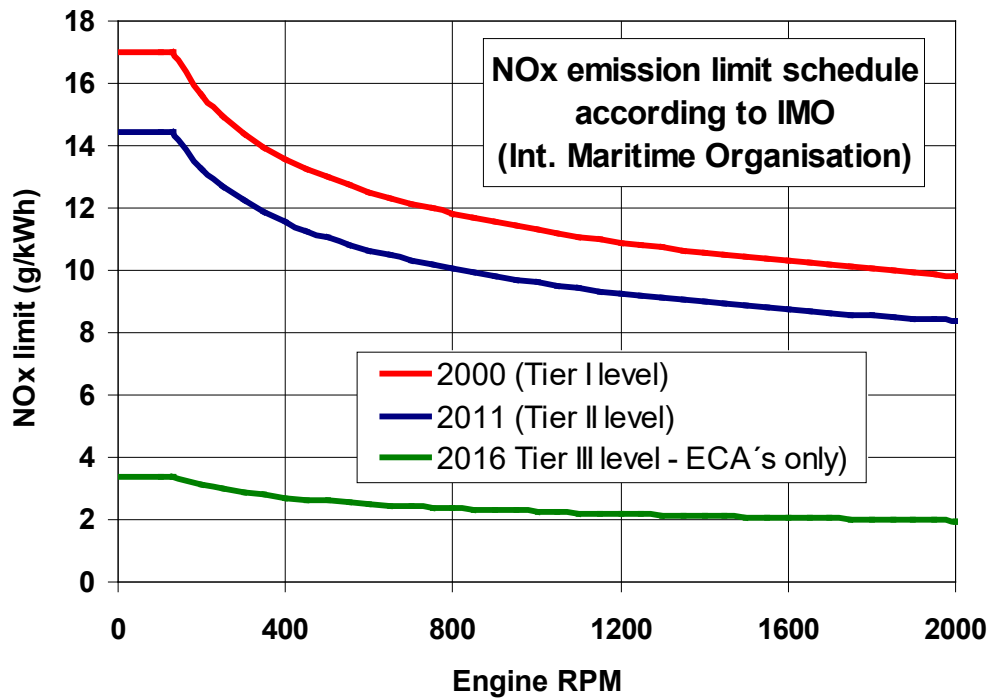

Figure 10 Maximum allowable fuel specific NO<sub>x</sub> emission rate according to IMO, MARPOL Annex VI

### NO<sub>x</sub> emission reduction technologies

The following two NO<sub>x</sub> reducing technologies can be used to reduce NO<sub>x</sub> emissions:

- Exhaust Gas Recirculation (EGR)
- Selective Catalytic Reduction (SCR)

**Exhaust Gas Recirculation** is a method to significantly reduce NO<sub>x</sub> emissions from marine engines. It is proven to be able to meet the Tier III NO<sub>x</sub> requirements, which applies to all new ships entering a NO<sub>x</sub> Emission Control Area (ECA) from 2016.

The illustration in Figure 11 shows an EGR system from MAN Energy Solutions. Part of the exhaust gas is diverted from the exhaust gas receiver through a wet scrubber, which cleans the gas and reduces the temperature of the exhaust gas. The gas flows through a cooler and water mist catcher and finally through the EGR blower which lifts the pressure to the scavenge air pressure (scavenging refers to the supply of fresh air inside the cylinder for a proper fuel/air ratio during compression). A water handling system supplies the scrubber with recirculating fresh water with the addition of NaOH to neutralize the effect of sulphur in the fuel.

The effect of this system will be that a minor part of the oxygen in the scavenge air is replaced by CO<sub>2</sub> from the combustion. The heat capacity of the scavenge air will be slightly increased and the temperature peaks of the combustion will be reduced. Accordingly, the amount of NO<sub>x</sub> generated in the combustion chamber is reduced but it is also followed by a minor fuel penalty. The NO<sub>x</sub> reduction value is dependent of the ratio of recirculating gas. EGR alters

the physical and chemical reactions during the generation of particles, hence EGR can influence the emission of particles both positively and negatively (Zhao, Li, Wang, Xu, & Yuan, 2019).

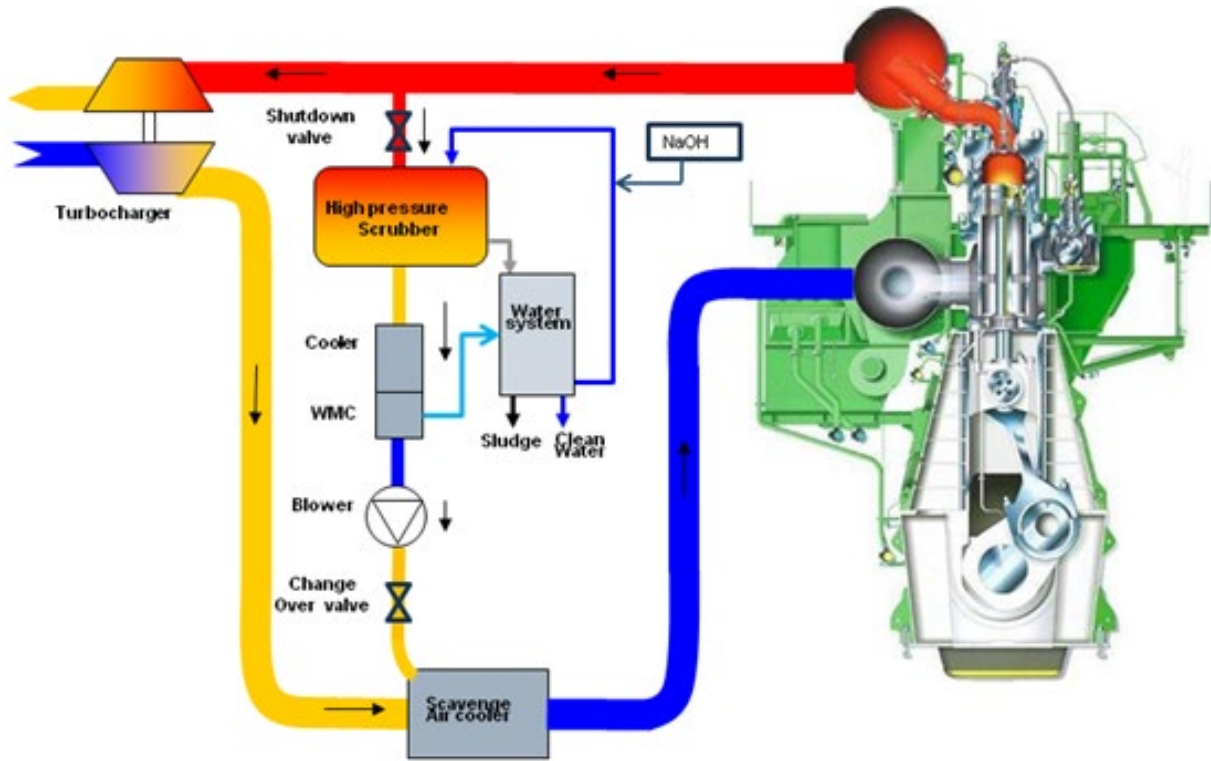

Figure 11 The principles of an EGR system (Courtesy MAN Energy Solutions)

In addition to the corrections in SFOC mentioned above, the electric power consumption of an EGR system has to be taken into account. The main consumers are the EGR blower, scrubber water pump and the water cleaning plant. The total electrical power consumption is approximately 2 % of the total main engine power, such that the SFOC is indirectly increased by 2 % plus corrections due to change in NO<sub>x</sub> emissions.

**Selective Catalytic Reduction (SCR)** is a well-known and widely used technology for removing NO<sub>x</sub> from exhaust gases and can be installed in any ship type. The SCR uses a catalyst to convert NO<sub>x</sub> into nitrogen and water by using reaction reducing agents, such as ammonia (NH<sub>3</sub>) or urea. The application of the technology may lead to a reduction in NO<sub>x</sub> emissions of up to 90 - 95%. To reach a 90 % NO<sub>x</sub> reduction, approximately 15 g of urea is needed per kWh energy from the engine. In addition to the catalyst that ensures reduction of NO<sub>x</sub>, the cleaning technology may also include an oxidation step, resulting in significant reduction of HC, CO and particles. In addition to the SCR catalyst, an SCR system consists of a reactor tank, a pump and control system for dosage of ammonia/urea.

One of the most critical problems is the relatively large space required for the SCR system and storage of ammonia or urea, especially in connection with a retrofit solution. On the other hand, in a recent case, from the Danish Navy, it was shown to be possible to install a retrofit SCR system on vessels with limited free space, for instance the so-called Diana Class patrol vessels.

### **Particulates**

The particulate fraction of the exhaust emission represents a complex mixture of inorganic and organic substances largely comprising elemental carbon, ash minerals and heavy metals and a variety of non-combusted or partially combusted hydrocarbon components of the fuel and lubricating oils. The emission of particulates has been found to be particularly affected by the sulphur content (as shown in Figure 65 with results from different investigations, section 7.4).

The scrubber technology reducing sulphur content automatically reduces particle emissions as well due to the equation above. Also, SCR can reduce particle emissions if an oxidation step is included.

### **HC and CO**

The hydrocarbon (HC) fraction of the exhaust gas will predominantly consist of un-burnt or partially combusted fuel and lubricating oils. Carbon monoxide (CO) is a product of incomplete combustion of carbonaceous material. Its formation in the diesel engine is thus principally a function of the excess air ratio, the temperature of combustion and the uniformity of the air/fuel mixture in the combustion chamber. In general, CO emissions are low due to high excess oxygen concentrations and an efficient combustion process. However, in poorly maintained engines or at low power ranges, the proportion of CO may be expected to increase considerably in relative concentration.

### **Greenhouse gas emissions**

Emissions of greenhouse gasses are the highest for diesel engines compared to the other technologies included in this catalogue (see section 7.4). The carbon in the diesel fuel combines with oxygen during combustion, resulting in CO<sub>2</sub> emissions. A smaller amount of N<sub>2</sub>O, which has a warming potential of the atmosphere that is 265 times that of CO<sub>2</sub> (over a 100-year period), is also released during the combustion. Additionally, incomplete combustion or inefficient burning of diesel oil can produce small amounts of CH<sub>4</sub>, which has a 28 times greater than CO<sub>2</sub> (over a 100-year period) (IPCC, 2013).

Besides the emission of GHG, ICE also have additional climate effects arising from emissions of black carbon (BC), also called soot particles. BC is not a greenhouse gas but is part of the particulate emissions formed by incomplete combustion (ranging from approximately 25 % to 85 % of the total particulate emission depending on the engine type). This is considered to be international shipping's second largest source of global warming after CO<sub>2</sub> emissions. BC absorbs energy from sunlight and transfer it as heat to the surroundings. When BC is deposited on snow- and ice-covered surfaces where sunlight is normally reflected, the reflection is reduced, whereby the energy from sunlight is absorbed as heat. BC therefore causes particular problems in the Arctic, because the particles, in addition to the direct contribution to warming the atmosphere, accelerate the melting (ICCT, 2017).

The emission of BC from internal combustion engines depends on, among other things fuel type, engine and after-treatment technology as well as engine wear and load. HFO (Heavy Fuel Oil) is considered to cause the largest emission of BC from shipping.

### Prediction of performance and costs

ICE is a mature technology in Category 4 (Figure 1), which is why general cost reductions through learning curves are unlikely. Also, the increase in energy efficiency in shipping engines over the last decades is observed to flatten out in recent years. As the most significant improvements to conventional shipping engines have been implemented, only small improvements can be likely. In the data sheets, no further increase in energy efficiency over time is assumed. There is consensus in the sector, that the required changes to reach significant reductions in emissions or increased engine efficiency, is a transition to other technologies and fuels.

Emission regulation will increase the operating costs through e.g., CO<sub>2</sub>-taxes and the emission cap and trade system (e.g. in the EU, Fit-for-55). These effects are not quantified in this catalogue.

### Uncertainty

The uncertainty of the data and modelling of ICEs and diesel is low, as it is a mature technology with many observable data points.

### Additional remarks

Besides the development in different engine technologies and fuels, other types of energy saving technologies can be expected to be applied in coming years – e.g. rotor sails, hydrodynamic measures etc. However, these technologies will be independent of the engine technology, and will presumably provide energy savings independently from the propulsion system.

## 2.1. Container ships

The use of containers started during the Second World War, and the first ship specifically designed for container transportation appeared in 1960, viz. the Supanya. The amount of cargo shipped in containers has increased considerably over the last 25 – 30 years, resulting in a rapid increase in both the number and the size of container vessels during this period.

### Size and capacity

The size of a container ship will normally be stated by means of the maximum number of TEU-sized containers it is able to carry. The abbreviation “TEU” stands for “twenty-foot equivalent unit”, which is the standard container size designated by the International Standards Organisation (ISO). The length of 20 feet corresponds to 6 meters, and the width and height of the container is about 2.44 meters. Therefore, the ship dimensions, such as the ship breadth, depends on the number of containers placed abreast on deck and in the holds. Thus, one extra container box abreast in a given ship design involves an increased ship breadth of about 2.5 meters.

Formerly, the average-loaded TEU container weighed about 10-12 tonnes, so the container vessels had often been dimensioned for 11 - 16 tonnes deadweight per TEU (Figure 32) but it is subject to large variations. However, the

maximum number of TEU containers to be transported is an important parameter for the container vessels. Therefore, the cargo capacity used today by most shipyards and ship-owners is equal to the maximum number of TEU boxes that can be stacked on the container ship, independent of the weight of the boxes. Therefore, this way of definition of the size of the container vessels, is generally used by ship designers and naval architects.

Depending on the TEU size and hull dimensions, container vessels can be divided into the following main groups or classes. However, adjacent groups will overlap and in some TEU areas no container vessels are available:

- Small Feeder  $\leq 1,000$  TEU
- Feeder 1,000 - 3,000 TEU
- Panamax 3,000 - 5,300 TEU
- Post-Panamax/New Panamax 5,300 -14,000 TEU
- Ultra large container vessels, ULCV  $>14,000$  TEU

The container fleet is developing fast. The ships are growing both in number and size (Figure 29), and the largest container ships delivered in 2022 had a capacity of approx. 23,000 TEU.

Container ships of up to 25,000 - 30,000 TEU, may be expected in the future, but this depends very much on the port infrastructure and corresponding operating efficiency, which are the limiting factors on the container ship sizes today. The larger the container ship, the more time and/or equipment is required for loading and unloading. As the time schedule for a container ship is very tight, possible extra time needed for loading/unloading means that, in general, larger container ships might have to operate at a proportionately higher service speed.

Feeder container vessels up to 3,000 TEU are normally applied for feeding the very large container vessels but are also servicing markets and areas where the demand for large container vessels is too low. The beam of the feeders is, in general, 16 - 32.2 m. Feeder container ships service a large part of Danish ports and sail to many different ports in the neighbouring countries such as Nordic countries, Germany, Netherlands and the UK.



Figure 12 Container feeder vessel (courtesy JR Shipping)

Larger container ships of over 3,000 TEU sail globally. The most representative size in the Danish context is a 12,000 TEU container ship. The large container ships primarily sail to/from Aarhus, the largest container port in Denmark, as well as Kalundborg and connect these ports closest to Denmark to e.g. Hamburg, Bremerhafen, Gothenburg, Rotterdam and other large container ports globally.



**Figure 13 Container ship with 12,000 TEU (Copyright RCL Group)**

The average daily capacity utilization of container ships is approximately 70 % of maximum capacity (payload).

### **Propulsion system**

Fuel prices have increased drastically over the last few years. This means that shipyards and ship-owners today have increased their attention on making the propulsion system as efficient as possible to reduce the fuel costs of the ship. It also means that a lot of effort is used to install the most efficient propeller and propulsion system in general. The bigger the propeller diameter is, the higher the obtainable propeller efficiency is.

To lower the specific fuel oil consumption (SFOC) more efficient long-stroke engines are preferable to short-stroke engine types. By extra investment in a Waste Heat Recovery (WHR)<sup>6</sup> system, sometimes inclusive of a shaft engine to absorb the electricity produced, the total fuel consumption of the container ship may be further reduced.

High fuel prices and the need for lower energy consumption incentivises reducing the ship speed in service, reducing the propeller speed and thereby also the engine speed. All this means that today, some container ships have been

---

<sup>6</sup> A waste heat recovery system (WHR) is a mechanical system consisting of a steam boiler connected to the main engine exhaust gas outlet. A steam turbine is fed with steam produced by the exhaust gas boiler. The turbine drives a shaft generator, which produce electricity for onboard use, when the ship is at sea.

ordered with two-stroke main engines with a relatively low engine speed type, which is normally used for bulk carriers and tankers.

The design ship speed used for especially container ships for several years has been relatively high because of the relatively low fuel prices and high freight rates. However, because of the considerable increase in fuel prices over the last few years, the design ship speed has since 2010 decreased for most ship types. Primarily for container ships. Figure 14 shows the development in maximum design speeds for container ships built before and after 2010, illustrating that the speed is declining for newer ships. The design ship speed might be even lower in the future, or the applied ship speed in service might be reduced.

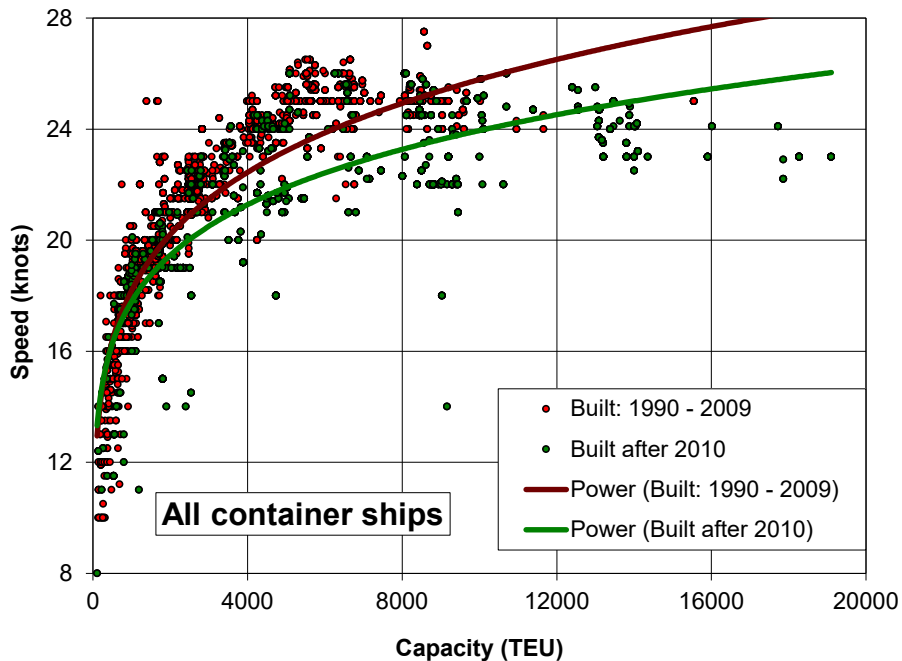

Figure 14 Typical maximum container service ship speed development

Today, container ships are very often operated at lower speeds than maximum as illustrated in Figure 33. The typical operating speed for ships built after 2010 and before 2010 corresponds to respectively 80 % and 60 % of the maximum design speed, which illustrates that older ships decide to sail on a speed which reduces the energy use and thereby fuel costs.

## 2.2. Bulk carriers and tankers

Bulk cargo is defined as loose cargo that is loaded directly into a ship's hold. There are both dry bulk carriers and wet bulk carriers, with the latter better known as tankers. Bulk carriers and tankers are two of the three dominating merchant ship types together with container vessels. Today, bulk carriers comprise about one third of the world fleet in tonnage terms.

The size of a bulk carrier or tanker will normally be stated as the maximum possible deadweight tonnage (DWT), which corresponds to the fully loaded deadweight.

In this technology catalogue tankers and bulk carriers are considered as one single ship type, as their size and general characteristics with respect to main dimensions are very similar.

### **Bulk carriers**

Bulk carriers transport bulk cargo such as oil, grain, ores, coal, cement, etc., or one which is not bundled, bottled, or otherwise packed, and which is loaded without counting or marking. A bulk carrier is therefore a ship in which the cargo is carried in bulk, rather than in barrels, bags, containers, etc., and is usually homogeneous and capable of being loaded by gravity.

Depending on the deadweight tonnage and hull dimensions, bulk carriers have been divided into the following main groups or classes. However, there will be some overlapping into adjacent groups and other sub classes can be found:

- Small < 10,000 DWT
- Handysize 10,000 - 35,000 DWT
- Handymax 35,000 - 55,000 DWT
- Panamax 55,000 - 80,000 DWT
- Capesize 80,000 - 200,000 DWT
- VLBC > 200,000 DWT (Very Large Bulk Carrier)

Even though the maximum overall length limited by the present lock chambers is 289.6 m (950 ft), the term Panamax size is defined as 32.3 m (106 ft) breadth, 225 m overall length, and no more than 12.0 m draught (39.5 ft) for passage through the old Panama Canal. The reason for the smaller ship size (length) used with these ship types is that a large part of the world's ports and corresponding facilities are based on the length of 225 m. The size of the Panama Canal used to be a decisive factor for the dimensions of Panamax bulk carriers, but it is not anymore since the opening of the new Panama Canal, which permits a breadth of 49 meters.

Due to the demand for more efficient ships, there is a tendency that the Panamax bulk carriers are not growing as much in deadweight, as the hull form simply has become too blunt and resulting in a relatively large propulsion power demand.

The range of weight of the Capesize bulk carriers, i.e. vessels with a deadweight tonnage higher than 80,000 DWT, has been increased. Often, the largest ones are called "Ultra Large Capesize" or just "Very Large Bulk Carrier" (VLBC). In this catalogue, the latter name of VLBC for Capesize bulk carriers bigger than 200,000 DWT is used.





Figure 15 Bulk carrier 60,000 DWT (Copyright Mitsui E&S Shipbuilding)

## Tankers

Tankers can be divided into main types such as chemical tanker, product tanker, crude oil tanker and gas tanker. The ship particulars of the gas tankers (LNG and LPG) are quite different from those of other types of tankers. Gas tankers are not dealt with in this study. Apart from this limited group of tankers, the other tanker types follow the same propulsion rules.

Depending on the deadweight tonnage and hull dimensions, tankers can be split into the following main groups or classes; there will be, some overlapping into adjacent groups<sup>7</sup>:

- Small tankers (< 10,000 DWT)
- Handysize (10,000 - 30,000 DWT)
- Handymax (30,000 – 55,000 DWT)
- Panamax (60,000 - 75,000 DWT)
- Aframax (80,000 - 120,000 DWT)
- Suezmax (125,000 - 170,000 DWT)
- VLCC (250,000 - 320,000 DWT)
- ULCC (> 350,000 DWT)

---

<sup>7</sup> There are some gaps between the categories, as certain ship sizes do not exist.



Figure 16 Oil tanker ship (Courtesy MAN Energy Solutions)

Bulk carriers and tankers sail to Denmark from a large variety of countries, ranging from neighbouring countries to Australia, depending on where materials relevant for bulk or tanker transport originate, e.g. countries in the Middle East for oil products, Baltic countries for wood chips etc. Bulk carriers and tankers normally do not sail on fixed routes but operate according to supply and demand of commodities.

### Propulsion systems

Tanker vessels and bulk carriers normally have a slow two-stroke propulsion system like container ships. However, the speed is significantly lower compared to container ships due to the ship design of a bulk carrier/tanker – with a much more blunt hull shape and a high so-called block coefficient, expressing the hull volume relative to the volume of a box surrounding the hull volume. Due to that reason higher speeds require very large amounts of energy which is unfeasible.

## 2.3. Ro-Ro cargo ferries

The word Ro-Ro ship is an abbreviation for Roll-on / Roll-off ships, i.e. ships on which wheeled vehicles rolls on board, when loading and rolls off board when unloading the ferry. Special ramps and doors are required to facilitate this. The vehicles may be the cargo itself as for instance in dedicated car carriers (which are not included in this catalogue) or the cargo may be carried by wheeled vehicles, such as trucks and trailers. Besides, some cargo is stowed and loaded/unloaded directly on the decks by forklift trucks or other terminal equipment.

A Ro-Ro cargo ship mainly transports vehicles able to carry goods i.e. trucks, trailers and in some special cases train wagons. In contrast, a Ro-Ro passenger ship, also called a conventional car ferry, mainly transports passengers including cars and trucks and is described in section 2.4.

Ro-Ro ships were developed in the 1950's, when road transport started booming and a demand for moving trucks and road trailers across water emerged. Soon after, trucks and road trailers started carrying the newly developed containers in increasing numbers. However, in Ro-Ro ships a large amount of space around the vehicles, is wasted and made this ship type inefficient regarding utilizing cargo volume as compared with the Lift-on / Lift-off (Lo-Lo) arrangements of the cellular container ships developed shortly after. But the Ro-Ro ships have an advantage in their very fast and efficient cargo handling resulting in quick turnaround times (short port time). This is a combination of the fast Ro-Ro loading and unloading process and the advantage that road trailers need relatively short time in the terminals, with no requirements for trans-shipment from one transport mode to another.

Ro-Ro cargo ferries normally operate on fixed routes between two ports. Examples in Denmark are the international routes Esbjerg – Immingham and Køge – Klaipeda. However, from other Danish ports (e.g. Copenhagen) Ro-Ro cargo ships are operated to different foreign countries

Ro-Ro ship sizes are classed as follows:

- Small: Length < 120 m
- Medium: 120 m < Length < 160 m
- Large: Length > 160 m



Figure 17 Ro-Ro cargo ferry operating from Denmark (Courtesy DFDS)

### Capacity and deadweight

The capacity of a Ro-Ro cargo ship is primarily measured in lane metres. The approximate maximum capacity of 40 ft trailers is equal to the total lane metres divided by 14.4. This is based on all single lanes being a multiple of 14.4 m in length allowing a lengthwise 0.30 m spacing between the trailers. Those Ro-Ro ships, which are designed to carry cars on the tank top, on permanent car decks and/or on hoistable car decks should be specified both with the maximum lane metres for trailers and with the reduced lane metres in combination with a specified maximum number of cars. The capacity of an intercontinental Ro-Ro ship is usually stated as a combination of its TEU-container capacity, deadweight, and car capacity. Lane metres in ordinary Ro-Ro cargo ships range from about 200 m to about 8,000 m and vary considerably with the ship length as can be seen from Figure 44.

The deadweight of ordinary Ro-Ro ships ranges from about 700 tonnes to 30,000 tonnes and in few cases up to about 45,000 tonnes (Figure 45). For a given ship length the deadweight, like the number of lane meters, varies considerably. This can be due to specified average weights of cargo units, arrangement requirements, number of decks, hull line shapes, speed, etc.

### Propulsion system

The propulsion system for Ro-Ro cargo ferries is usually a four-stroke engine, however, special cases with a two-stroke design have been observed in the past, e.g. some DFDS Ro-Ro cargo ships.

There are incentives to reduce the service speed to save on fuel costs, and there is a tendency that service speed has decreased slightly, however, Ro-Ro cargo ferries do not have the same time flexibility compared to e.g. cargo ships due to fixed time schedules and competition with road transport.

## 2.4. Ro-Ro passenger ferries

Ro-Ro passenger ships, also called car passenger ferries, are characterized by having at least one deck for vehicles and mostly one or more decks for passengers. Very large Ro-Ro passenger ships very often have two decks for vehicles and many decks for passengers, especially if they are designed with passenger cabins for longer sailing routes. They are in general designed according to the drive-through principle, where vehicles are loaded at one end and unloaded at the opposite end. When small ferries (which is a special category of passenger ferries, see section 2.6) are excluded, the normal passenger ferries may be from about 50 m to about 230 m in length (Figure 48).

Ferries dealt with in this chapter are built of steel and have service speeds normally not exceeding 30 knots. High-speed ferries (see section 2.5), which include fast Ro-Ro car passenger ferries and fast ferries for passengers only, are built of light materials and usually have service speeds exceeding 30 knots.

Over the years train/passenger ferries have primarily been carrying lorries (trucks), buses, and cars. The demand for car/passenger ferries has, since their introduction in the 1930s, experienced a steady growth, in particular, where a ferry route connects ports, where the distance on land between these ports is much longer than the sailing distance.

A ferry service is normally a route with a fixed timetable and is therefore in a sense a sort of permanent liner shipping operation. Most routes are round trips between two ports only, but on some routes of several hours duration there may be extra ports of call.

In Denmark Ro-Ro passenger ferries serve the many islands with larger ferries operating to and from Samsø, Ærø, Læsø, Als and Bornholm and many smaller Ro-Ro passenger ferries have service to many of the smaller islands in Denmark or crossing the Limfjord (the smaller ferries are further described in section 2.6). Additionally, Denmark also has some even larger Ro-Ro passenger ferries, which are operated on international routes such as Rødby-Puttgarden, Elsinore-Helsingborg, Hirtshals-Kristiansand, Frederikshavn-Gothenburg and Copenhagen-Oslo where the largest Ro-Ro passenger ferries operate today.



Figure 18 Ro-Ro passenger ferry used between Copenhagen and Oslo (Courtesy DFDS)

### Capacities and deadweight

Since individual car ferry designs vary considerably regarding number of car decks, number of passengers including passenger areas, speed, and machinery etc. it is not surprising that variations in capacities for a given ship length are great as well.

For this analysis a 1,600-passenger ferry is selected as a representative size, corresponding to an average of a ferry to Bornholm and the ferry between Copenhagen and Oslo. For the data sheets smaller and larger types are selected to illustrate the lower and upper bound of this ship type and the large variation. The 3 sizes are as follows:

- 400 passenger ferry with a length of 91 m and a gross tonnage of approx. 7,200 GT
- 1,600 passenger ferry with a length 139 m and a gross tonnage of approx. 19,000 GT
- 3,500 passenger ferry with a length of 215 m and a gross tonnage of approx. 60,000 GT

The smaller size represents some of the ferries operating in Denmark like Spodsbjerg-Tårs or Kalundborg-Samsø, while the largest ferry is selected to cover the whole expected range of ferries currently operating in the Baltic Sea, which might be operated from Denmark in the future.

Car ferry capacities are stated as the maximum of passengers, which can be carried (Figure 44). Two other key parameters are the length of lanes (Figure 49) for trucks and busses and the number of cars (Figure 50). In section 7.2 the graphs showing the three parameters, cars, passengers, and lane meters as function of the ship size (length between perpendiculars,  $L_{pp}$ ) are shown, indicating the large individual variations in both car, passenger and lane meters for a given ship length/ship size.

### Propulsion system

The propulsion system for Ro-Ro passenger ferries is usually a four-stroke engine, however, special cases with a two-stroke design have been observed in the past.

Speeds in service vary from approximately 12 knots on the smallest ferries, up to approx. 30 knots according to the ShipPax data (Figure 51). It is important to have in mind, that the service speed is normally adapted to suit an adequate timetable for the actual ferry route. An example of speed reduction to save fuel costs is the DFDS ferry between Copenhagen and Oslo, where lower speed has led to an increase in crossing time of two to three hours within the last 10 years.

## 2.5. Fast ferries

Fast ferries are high-speed crafts (HSC) for transport of passengers and vehicles. However, smaller ones are generally for passengers only. Fast ferries are normally built of lighter materials than steel, usually aluminium alloys, and are equipped with high-powered, high-speed machinery able to provide the craft with service speeds from about 25 knots to more than 40 knots. The ships may either be of mono-hull type or of multiple-hull type, but most commonly they are twin-hulled (catamarans). Fast ferries designed only for passengers usually have one enclosed deck, but more decks are possible. Those which are designed for combined transport of passengers and vehicles usually have one or more vehicle decks and one or more passenger decks above like the conventional Ro-Ro passenger vessels.

To reach higher speeds than possible with conventional ships, the design of fast ferries focuses on increasing the ratio of the payload of the ship compared to the total weight of the ship (displacement tonnage). Typically, the lightweight (weight of the ship excluding deadweight) is reduced by using aluminium alloys as construction material instead of steel, adopting several materials and features originally developed in the aircraft industry. The engines used in fast ferries are usually lighter, higher powered and operated at higher revolutions compared to conventional ships. Instead of conventional ship propellers, waterjets have been introduced. In addition to these constructional and outfitting features, also the application of different hydrodynamic advantages has considerably reduced the water resistance obtainable by semi- or fully-planning hulls, which have contributed to higher speeds.

To increase the relative payload, the amount of fuel is also limited, which limits the vessel's range.

Fast ferries of the types and sizes available today are best suited for deployment on short-haul services ranging from a few nautical miles up to distances where the crossing takes 2 – 4 hours. Examples of these are a crossing of a Norwegian fjord being a fairly short trip and the crossing of the Irish Sea between England and Ireland being a long trip. On such routes crossing times for fast ferries have typically been reduced by 50-60 pct. compared to conventional ferries.

There are several fast ferry types, which are quite different from each other. The most common ones include:

- Hovercraft, hydrofoil vessels
- SES (surface effect ships)

- Catamarans
- Slender monohull vessels

Experience shows that fast ferries require more costly maintenance and repairs than conventional ferries. Various components are more vulnerable, and the high speed puts extra pressure on the technical equipment. Catamarans are in many respects simpler and less costly than some of the other fast ferry types. The catamaran consists of two hulls widely separated and connected with a body or bridge structure elevated well above the water surface (for protection against wave impact in rough weather) on which a superstructure and possibly deck houses are superimposed. The deck has a very large area, mainly due to the ample beam. On some catamarans the two hulls have asymmetric bodies, others symmetric ones. The engine rooms with the machinery are arranged in both hulls with one complete propulsion plant in each hull.

Molslinjen is operating catamaran ferries in Denmark. In 2023 the world largest catamaran ferry, Express 5, with a capacity of 451 cars and 1,600 passengers was delivered. The ferry operates on the route between Rønne and Ystad together with 2 other catamaran ferries for the company Bornholmslinjen. Another route is between Zealand and Jutland, where the high-speed catamaran ferries approximately halved the crossing time compared to conventional ferries.



Figure 19 Molslinjen's high-speed catamaran ferry (Courtesy Molslinjen)

### Capacity and deadweight

The fast ferries normally have a capacity range of approximately 70 to 450 cars, within a length of 60-115 meters (Figure 52). The passenger capacity is 450 to 1,600 (Figure 53) with a deadweight range of 250 tonnes to 1,000 tonnes (Figure 54).

### Propulsion system

Fast ferries have from two to four propulsors, which may be screw propellers or waterjets.

In IMO terminology a craft is a high-speed craft (HSC) when it is capable of a maximum speed  $V_{\max}$ :

$$V_{\max} > 3.7 \cdot \nabla^{0.1667} \text{ m/s}$$

Where  $\nabla$  is the displacement in  $\text{m}^3$  corresponding to the design waterline.

## 2.6. Small ferries

Denmark has around 50 domestic ferry routes served by small ferries with a length of 10 – 60 meters and with a car capacity of up to around 40 cars (see Figure 58). These ferries belong to a special ferry segment with many different ferries with only small accommodation for passengers, as the sailing distance and associated sailing time is generally short. The number of passengers varies from very few passengers up to 400.



Figure 20 The small ferry M/F Mary sailing between Hvalsund and Sundsøre (Copyright Brian Krause)



### Capacity and deadweight

Based on ferry statistics for the small ferries, the maximum payload is typically 75 – 85 % of the maximum deadweight, which means that a payload of 80 % is used in the calculations.

Many of the ferries have a maximum passenger capacity of typical 98 or 147 passengers (see Figure 59) which is the number of persons, which can be evacuated safely by a crew of 2 or 3 persons respectively according to the official safety rules and judgements by the Danish Maritime Authorities. Due to the economy for the municipalities where the ferries operate it is very important to keep the crew number as low as possible. Additionally, the demand for small ferry transport in Denmark is low, with the actual number of passengers on a trip often is below 10. Therefore, the passenger capacity is not expected to increase in the future.

Due to the small physical size of the ferries and the low cargo carrying capacity, the lightweight and the deadweight are relatively low resulting in a moderate displacement of the ferries.

### Propulsion system

The small ferries are either single ended ferries or double enders, with a propeller in each end, such that the ferries do not need to turn on the way in and out of the port. This reduces the manoeuvring and thereby the crossing time, which is beneficial on especially shorter sailing distances, as the average sailing speed will be lower for a double ended ferry. For a given transport capacity and speed the difference in propulsion power for a single ender versus a double ender is not significant. Hence, a single ender is assumed in the generic ship design model developed in this catalogue for prediction of energy demand per nautical mile and per nautical mile per tonne payload.

Based on the speed and water depth data for the different ferry routes in Figure 60 and Figure 61, speed and power calculations have been carried out at 6, 8 and 10 knots assuming an average water depth of 7 m, which results in a power increase of 5 – 20 % with the highest increase at 10 knots.

## 3. Qualitative description – methanol internal combustion engine

### Contact information

Containing the following information:

- Contact information: The Danish Energy Agency, Ulrich Lopdrup, [ulo@ens.dk](mailto:ulo@ens.dk)
- Author: HOK Marineconsult ApS, Hans Otto Kristensen and COWI
- Reviewer: The Danish Energy Agency

### Description of propulsion technology and fuel

Methanol is a versatile alcohol that has emerged as a promising candidate in the realm of marine propulsion. As a clear, colourless liquid, methanol possesses unique properties that make it an attractive option for fuelling ships. It is a simple chemical that is easy to produce by a multitude of processes. There are currently three main engine options for methanol usage: dual fuel methanol-diesel used in a compression ignition engine (with an individually injected cylinder),

a lean-burn spark ignition engine or emulsified methanol used as a pre-blended mono fuel in a diesel engine. In this catalogue only dual fuel engines are described as they are the most dominant engines on the market today.

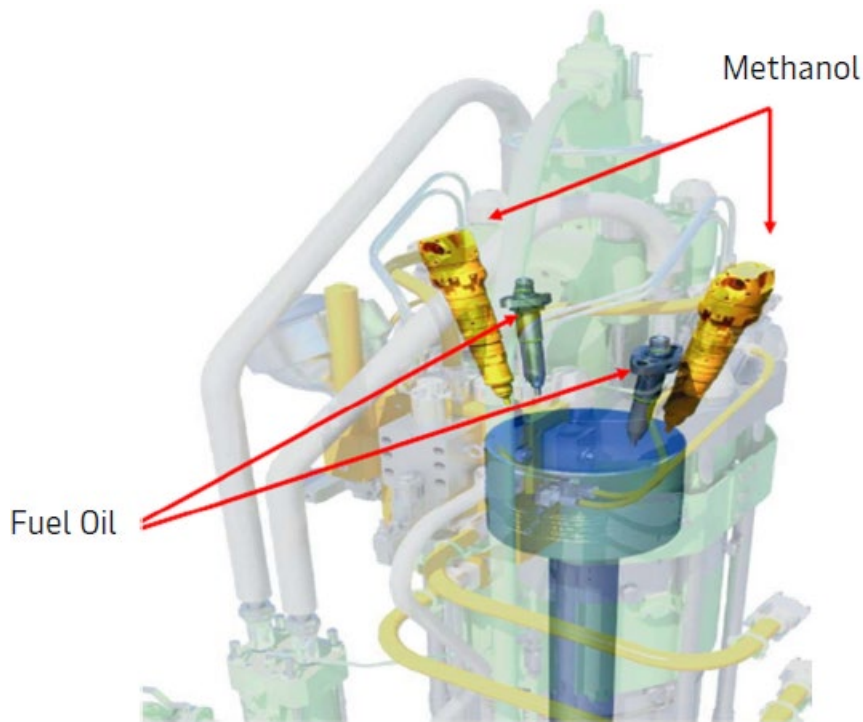

**Figure 21 Illustration of a dual fuel engine with separate fuel pipes and injection systems for methanol pilot fuel oil (Courtesy MAN Energy Solutions)**

Utilizing the diesel principle ensures that the methanol burning engine has the same power output and efficiency as the fuel oil burning engine. In addition, the benefits apply in both methanol (dual-fuel mode) and diesel oil (compliant fuel only mode) operating modes. The engine power output is not affected by ambient conditions, and it is only slightly sensitive to the quality of methanol, which is currently benchmarked to IMPCA (International Methanol Producers & Consumers Association).

### **Advantages/disadvantages**

Many operators consider methanol as one of the future carbon-neutral fuels, which however, depends on the origin of the inputs used to produce the methanol. Even if methanol is produced as a carbon-neutral alternative, there will still be NO<sub>x</sub> and N<sub>2</sub>O emissions and unless carbon neutral diesel fuel (like second generation biofuel or e-fuel) is used as pilot fuel there will be some CO<sub>2</sub> emissions stemming from the pilot fuel. Obtaining 100 % carbon free well-to-wake fuel consumption accounting for all upstream emissions will, therefore, still prove difficult.

Methanol is easy to handle, compared to e.g. hydrogen and ammonia, and it is stored and injected into the engine as a liquid, just as easily as conventional bunker fuels. On the other hand, methanol has a low flash point, which means

storage tanks need double sealing to minimize the risk of explosions, which is a disadvantage compared to conventional fuel.

As for other types of dual fuel engines, methanol has the potential as a retrofit solution for newer engines already in service. All ME-C engines are delivered as so-called “dual fuel ready” engines. Therefore, in new projects, the engines are prepared for later conversion to dual fuel independent of vessel application (tanker, bulk, container, etc.).

As of November 2020, methanol has been approved and will be incorporated in the “International Code of Safety for Ships using gas or other low-flashpoint fuels (IGF code), which means that, in contrast to ammonia, there are regulatory procedures and safety standards in place for methanol.

Carbon neutral or green methanol can be produced through a variety of processes e.g. from biomass, municipal solid waste (MSW), or other biogenic matters, as well as via electrolysis coupled with a sustainable carbon source e.g. direct air capture. A lack of appropriate CO<sub>2</sub> sources might pose a challenge for methanol production.

The energy density of methanol (19.9 MJ/kg, see also Table 6) is around half that of MGO, so larger fuel tanks or more frequent bunkering are needed. For container ships, tanker, and bulk carriers the larger tanks correspond to roughly 5 – 10 % less payload. However, the increase in tank size can be mitigated through more frequent bunkering.

### Bunkering or charging infrastructure

Methanol is liquid at ambient temperature and pressure and can be handled, stored, and pumped like other liquid fuels. The low viscosity of methanol and volatility will require modifications to the bunkering process, onboard storage and handling, but unlike pressurized or cryogenic fuels (e.g. hydrogen, ammonia), methanol does not require refrigeration, liquefaction or vaporization equipment or pressurized storage tanks. Unlike other alternative fuels methanol only requires minor modifications to the existing bunkering infrastructure (Padeti, 2022).

Even prior to the Marine Safety Committee decision in IMO, classification societies have started addressing those bunkering and handling concerns. In September 2020, Lloyds Register unveiled the Bunkering Technical Reference on Methanol, which outlines procedures for ship-owners/operators, ports, bunker suppliers, and other stakeholders. Meanwhile, DNV<sup>8</sup> has in the past year added methanol to its Alternative Fuels Insight platform, indicating that large-scale bunkering infrastructure for methanol<sup>9</sup> can now be found at more than 100 ports around the world, predominantly in northern Europe.

In 2023, the ports of Gothenburg and Antwerp-Bruges have conducted ship-to-ship methanol bunkering. Following a tender for PtX in Denmark, the first PtX production facilities were initiated in 2023. The tender supports 5 PtX projects.

### Interaction with the energy system

Methanol has traditionally been sourced from natural gas, with no direct impact on the energy system. However, for methanol to be a sustainable alternative to fossil fuels, it must be produced through sustainable production measures. This can for example be through gasification from sustainable sources of biomass or as a synthesized product through

---

<sup>8</sup> Det Norske Veritas, an international accredited registrar and classification society.

<sup>9</sup> The majority of methanol currently available is not produced as a carbon neutral fuel but based on fossil resources.

hydrogen from electrolysis using renewable electricity and a source of sustainably derived carbon dioxide. These two pathways to production of methanol are, respectively, returning bio-methanol and e-methanol, indicating their non-fossil origins.

E-methanol is one of many potential products from PtX, utilizing the conversion of renewable electricity to hydrogen as an energy carrier. As PtX is expected to play a significant role in the transition of the transport and industry sectors on a global scale, it introduces a similarly large demand for renewable electricity for electrolysis. The demand for electrolysis required to support PtX-processes will potentially challenge both the renewable energy production capacities and the grid infrastructure, pushing the current limits of the grid. However, by utilizing excess renewable energy during off-peak periods, electrolysis can store renewable energy as hydrogen. This can be converted into e-fuels, such as e-methanol. Consequently, whether electrolysis will constrain or benefit the grid operation will depend on how it is operated. The ability to run flexibly, combined with great sensitivity of electrolysis production to the electricity price means that the electrolysis plant is expected to respond to flexibility incentives and to act accordingly in relation to the electricity system. Because of this ability to be flexible, PtX also has a potential to reduce some of the challenges that will emerge associated with the future increasing need for network reinforcements, as well as the challenges of ensuring the long-term security of electricity supply.

### Current market and technological status and future development perspectives

In the literature, the use of methanol as an alternative energy carrier for maritime shipping is considered to be an option for implementation in the short to medium term, based on its availability, emission reduction potential and energy density. However, there is uncertainty about the economic feasibility, e.g. the fuel cost and the business case of transitioning to methanol.

There are already several high-profile vessels operating with methanol. In 2015, Swedish operator Stena Line's 2000-built cruise ferry *Stena Germanica* underwent a retrofit as part of a joint venture between Stena AB, Wärtsilä, Methanex Corporation, and the ports of Gothenburg and Kiel, which the ferry travels between. *Stena Germanica* is fitted with 4 x Wärtsilä 8ZAL40S four-stroke dual fuel engines, and achieves significant reduction in NO<sub>x</sub> (60 %) and SO<sub>x</sub> (90 %) emissions. While it is generally considered to have been a success after five years of operation, the Germanica project was not without its challenges, both regarding seal leakage caused by methanol's low viscosity and ensuring the safety of the fuel delivery system.

As of mid-2023, DNV calculated that the total order book for methanol-fuelled ships has reached 140 vessels for delivery over the next five years, primarily for the container, bulk carrier, and tankers segment (DNV, 2023).

Maersk has had a first ship with a dual fuel engine able to operate on green methanol delivered in September 2023. The vessel is a feeder container ship of 2,100 TEU, called *Laura Maersk*. Maersk has another 24 vessels with dual fuel engines of larger ocean going container ships (9,000 – 17,000 TEU), in order.

Another operator - Evergreen - has announced an order of 24 methanol dual fuel container ships with a capacity of 16,000 TEU each.

## Environment and climate

### Specific fuel consumption (SFC)

As the specific energy content per kg methanol is only 19.9 MJ/kg compared to 42.7 MJ/kg for MGO, the SFC for a methanol driven engine will be proportionally higher as follows (assuming the same engine efficiency as stipulated by (MAN Energy Solutions, 2023):

$$\text{SFC (methanol 2 stroke engine)} = 42.7/19.9 \times 0.170 \text{ kg/kWh} = 0.365 \text{ kg/kWh}$$

$$\text{SFC (methanol 4 stroke engine)} = 42.7/19.9 \times 0.190 \text{ kg/kWh} = 0.408 \text{ kg/kWh}$$

Taking into account that 5 % pilot diesel fuel is used for the combustion process, this small amount of diesel oil results in following SFC for a methanol engine:

$$\text{SFC (2 stroke, methanol engine + 5 \% diesel)} = 0.95 \times 0.365 \text{ kg/kWh} + 0.05 \times 0.170 \text{ kg/kWh} = 0.355 \text{ kg/kWh}$$

$$\text{SFC (4 stroke, methanol engine + 5 \% diesel)} = 0.95 \times 0.408 \text{ kg/kWh} + 0.05 \times 0.190 \text{ kg/kWh} = 0.397 \text{ kg/kWh}$$

### Air pollution emissions

Methanol is used together with a pilot fuel. If the pilot fuel is fossil based diesel oil, there will be emissions that need to be taken into account (Harmsen, 2021).

Sulphur emissions from methanol are very low and are primarily based on pilot fuels, which makes it attractive for ships operating in IMO emission control areas to meet the requirements for lower sulphur emissions. Furthermore, since the methanol molecule contains no carbon-to-carbon bonds, it does not produce much particulate matter or soot when burned. The SO<sub>x</sub> and particulate emissions of methanol together with the diesel pilot fuels are approximated based on (Harmsen, 2021) and determined through the equations below:

$$\text{PM (methanol + 5 \% pilot fuel)} = 0.034 \text{ g/kWh} \times 0.95 + 0.27 \text{ g/kWh} \times 0.05 = 0.046 \text{ g/kWh}$$

$$\text{SO}_x \text{ (methanol + 5 \% pilot fuel)} = 0.007 \text{ g/kWh} \times 0.95 + 0.4 \text{ g/kWh} \times 0.05 = 0.027 \text{ g/kWh}$$

The HC and CO emissions using methanol have not yet been measured officially but they will be lower than using diesel oil. A reduction of HC and CO emissions per kWh of 75 % seems to be a reasonable conservative assumption.

To comply with Tier III regulations of the IMO, a simple methanol-and-water blending system has been introduced to lower the NO<sub>x</sub>-level for Tier III compliance. Water for the blending system can be produced on board. By installing the blending system, selective catalytic reduction (SCR) systems and exhaust gas recirculation (EGR) systems can be avoided, at significant cost savings. The latest ME-LGIM engine order included the methanol-and-water blending system.

### Greenhouse gas emissions

CO<sub>2</sub> emissions per tonne methanol are lower than for MGO/HFO (Table 8). Even though methanol has a lower energy density (Table 6), the CO<sub>2</sub> emissions per nautical mile are still below the level of MGO/HFO. There are also N<sub>2</sub>O and CH<sub>4</sub> emissions (with a warming potential that is respectively 265 times and 28 times greater than CO<sub>2</sub> over a 100-year period) from the combustion of methanol (Table 9). As methanol has to be used with a diesel pilot fuel, these emissions have to be taken into account. Besides the emission of GHG, ICE running on methanol also have additional climate effects arising from emissions of black carbon (BC), also called soot particles. BC is not a greenhouse gas but is part of the

particulate emissions formed by incomplete combustion (see page 25 under conventional diesel propulsion). However, the particulate emissions compared to ICE running on MGP/MDO are considerable lower.

The large focus on green methanol as an alternative fuel stems from the potential to reduce greenhouse gases, when accounting for the entire value chain, meaning well-to-wake emissions, which are not reported in this catalogue. A significant challenge for the production of bio- and e-methanol will be securing sufficient sustainably derived CO<sub>2</sub>. Both bio- and e-methanol require CO<sub>2</sub> as input. If the final methanol product is to be considered sustainable and abate emissions from fossil alternatives, the source of CO<sub>2</sub> is vital. The demand on sustainably derived CO<sub>2</sub> will expectedly surge at a high rate, as an increasing count of applications of sustainable CO<sub>2</sub> in fuels will replace conventional fuels. If the CO<sub>2</sub> can't be derived from sustainable sources, the emissions from methanol will stem for fossil sources, leading back to the original issue of abating the increase of CO<sub>2</sub> in the atmosphere. The scarce stock of sustainable CO<sub>2</sub> poses a threat to the sustainability of both bio- and e-methanol. Future technological developments, such as direct air capture (DAC) may, however, enable yet another source of sustainable applications of CO<sub>2</sub>.

### **Production sites**

Examples of shipyards contracted with building some of the ordered methanol container ships are in South Korea's Hyundai Heavy Industries (Maersk) and Japan's Nihon Shipyard (Evergreen).

### **Prediction of performance and costs**

The maturity of the technology is in late Category 2 ("pioneer phase") and entering Category 3 ("commercial technologies with moderate deployment") according to Figure 1. There are differences between the ship types, with some tankers and a Ro-Ro passenger ferry in operation, the first container feeder ship is in operation since September 2023, while other ship types are still being built and tested.

Benchmarked against conventional fuel capabilities, additional capital expenditure (CAPEX) for the methanol dual fuel capability is in the range of 8 - 12 %, according to Maersk's press release (Maersk, 2022) for these vessels. This is lower than the 10 - 15 % communicated in the press earlier and is due to economy of scale effects. Costs can be expected to decrease when the engines become more widely available due to economies of scale.

OPEX are primarily driven by fuel costs. Methanol prices are significantly higher compared to MGO/HFO and therefore increase OPEX. The high fuel costs can make costly investments worthwhile, which will improve the energy efficiency of methanol over time. Due to high uncertainty about the magnitude, this is not quantified in the data sheets.

Regarding maintenance and labour, a dual fuel system has larger costs compared to a conventional ICE due to the higher complexity of the engines and fuel supply systems (Bui, Perera, & Emblemståg, 2022).

### **Uncertainty**

There is some uncertainty as the technology is not yet widespread, and therefore not giving many data points. The largest uncertainty is whether the production of methanol will reach the required amounts in the future and how large the prices difference will be between methanol and diesel oil.

### **Additional remarks**

No additional remarks.

### 3.1. Container ships

The first methanol-fuelled container ship Laura Maersk with a 2,100 TEU capacity was built in the Hyundai Mipo Dockyard in South Korea and was named in September 2023. Larger container ships ordered by Maersk are planned to be delivered between 2024 and 2027.



Figure 22 Laura Maersk, the first dual fuel container ship by A.P. Moller-Maersk that can run on methanol (Courtesy State of Green)

### 3.2. Bulk carriers and tankers

Lindanger was the first dual fuel methanol-fuelled tanker, built at Hyundai Mipo shipyard in South Korea in 2016 and has a two-stroke dual fuel engine designed by MAN and Hyundai. There is currently a global fleet of 18 methanol-fuelled tankers (DNV, 2023).



Figure 23 Lindanger, a 50,000 DWT tanker with a dual fuel engine that can run on methanol (Courtesy Westfal-Larsen)

### 3.3. Ro-Ro cargo ferries

There is no information about Ro-Ro cargo ferries currently operating on methanol. Several companies have ordered Ro-Ro cargo ferries expected to be delivered in the upcoming years. Examples are two ferries ordered by Stena Line, being built at the China Merchants Jinling Shipyard (Weihai) using Wärtsilä engines. They are expected to have a 2,400 lane-meter capacity and will operate in the Stena Line Irish Sea system. The expected delivery is in 2025.

### 3.4. Ro-Ro passenger ferries

The first ferry to run on methanol was Stena Germanica with a capacity for 1,500 passengers, 300 cars and approximately 4,000 lane meters. The ferry was not newly built but retrofitted in 2015 with a Wärtsilä four-stroke dual fuel engine. Other examples of methanol driven Ro-Ro passenger ferries have not been found in the research for this catalogue.

### 3.5. Fast ferries

There is no information about fast ferries currently operating on methanol, however, technically it can be possible.

### 3.6. Small ferries

There is no information about small ferries currently operating on methanol, however, technically it can be possible.



## 4. Qualitative description – internal combustion engine with ammonia

### Contact information

Containing the following information:

- Contact information: The Danish Energy Agency, Ulrich Lopdrup, [ulo@ens.dk](mailto:ulo@ens.dk)
- Author: HOK Marineconsult ApS, Hans Otto Kristensen and COWI
- Reviewer: The Danish Energy Agency

### Description of propulsion technology and fuel

Ammonia, traditionally known for its role in fertilizers and various chemical processes, is emerging as a viable and promising marine fuel. As an energy carrier, ammonia presents several attributes that make it a compelling choice for decarbonizing the shipping industry. The development of internal combustion engines fuelled by ammonia is building upon the experiences from LNG and methanol dual-fuel engines.

Ammonia (NH<sub>3</sub>) is an attractive fuel as it does not lead to CO<sub>2</sub> emissions from combustion. Ammonia does not contain carbon and can be made using hydrogen from electricity from renewable energy sources and nitrogen separated out of the air. However, if not properly handled, there is a risk of emitting N<sub>2</sub>O emissions which is a greenhouse gas. For ammonia to work as a fuel in an ICE, it has to be combined with a smaller amount of pilot fuel, e.g. diesel or hydrogen. The latter can be derived directly from ammonia through on-board cracking of the ammonia. The dual fuel engine follows the same principles as the one for methanol as illustrated in . Compression engines for the use of ammonia are currently developed worldwide. IEA is forecasting that ammonia will account for more than half of marine fuels by 2070 (IEA, 2020).

### Advantages/disadvantages

Ammonia is very toxic, which is why there are considerable security concerns. However, ammonia is one of the most frequently transported chemicals worldwide, and therefore regulation and safety procedures etc. for transporting ammonia are already in place, in some use cases. The European Maritime Safety Agency (EMSA) states, that related health, safety and environmental challenges can be managed and sees ammonia as a potential long term marine fuel (EMSA, 2022). Both EMSA and IMO are working with the development of new safety rules for use of ammonia, which for example already are existing for use of methanol. A similar work is done by the classification societies (of which some have already ammonia rules ready) such that the whole maritime industry has a well organised rule framework for use of ammonia in the future. Due to the safety concerns, ammonia is met with greater challenges as an option for passenger ferries, and in the short run first and foremost expected to be implemented in relation to Ro-Ro cargo ships, container ships, bulk carriers and tankers.

The energy density of ammonia (18.6 MJ/kg, see also Table 6) is around half that of MGO, so larger fuel tanks are needed for similar energy volumes. For container ships, tanker and bulk carriers the larger tanks correspond to roughly 5 - 10 % less payload. As for methanol the increase in tank size can be mitigated through more frequent bunkering.

### Bunkering or charging infrastructure

Ammonia can be stored in a liquefied state either at pressures of approximately 17 bar at ambient temperature or refrigerated (-33°C) at ambient pressure (EMSA, 2022), which makes it more challenging to handle compared to methanol or diesel oil.

Ammonia is used as input for products in the fertiliser and chemical industries, which is why ammonia already is transported in large amounts worldwide, thus storage and distribution infrastructure is readily available. Due to its high toxicity and security concerns, classification societies evaluate that ammonia cannot be bunkered in ports with residential areas close by.

The ammonia bunkering process is somewhat similar to ammonia handling as a commodity cargo, but the key differences include the quantity of ammonia transferred, tank types and capacity, operating mode and frequency. As many ammonia terminals exist the introduction of bunker barges is seen as the next step to complete the necessary bunkering infrastructure.

Bunker trading companies like Yara and Bunker Holding have announced to focus on key trade routes and port locations where ammonia bunker fuel could be adopted by first movers. In a consortium including Yara and Equinor, a network of ammonia bunker fuel barges across Scandinavia is being established. These projects have not reported of any ship-to-ship bunkering trials being conducted so far.

### Interaction with the energy system

Large amounts of renewable energy are needed for the production of green hydrogen, which is the basis of green e-ammonia. The hydrogen can be produced through electrolysis, powered by renewable electricity, ensuring a fossil-free production process. This makes ammonia a carbon-free energy carrier. The demand for electrolysis required to support PtX-processes will potentially challenge both the renewable energy production and the grid infrastructure, as it may demand more renewable energy than what is accessible at a given point in time, as well as pushing the limits of the grid. However, by utilizing excess renewable energy during off-peak periods, electrolysis can store renewable energy in the form of hydrogen for e-fuels, such as methanol and ammonia. Consequently, whether electrolysis will constrain or benefit the grid operation will depend on how it is operated. The ability to run flexibly, combined with great sensitivity of electrolysis production to the electricity price means that the electrolysis plant is expected to respond to incentives and to act with flexibility in relation to the electricity system. Because of this ability to be flexible, PtX also has a potential to reduce some of the challenges that exist associated with the future increasing need for network reinforcements, as well as the challenges of ensuring the long-term security of electricity supply. Ammonia's high volumetric energy density compared to hydrogen supports seasonal energy storage and potentially contributes to a dynamic hydrogen infrastructure, potentially increasing grid flexibility and sustainability.

### Current market and technological status and future development perspectives

First engines using ammonia are expected to be delivered in 2024 (Mærsk Mc-Kinney Møller Center, 2023), meaning that the technology is less commercially mature compared to methanol. Leading engine developing companies (e.g. MAN Energy Solutions, Wärtsilä) have done intensive research and development efforts into developing solutions for using ammonia as a fuel. Several consortiums and partnerships have announced projects with different ship types in focus. A consortium of Lloyd's Register, Mediterranean Shipping Company and MAN Energy Solutions are currently designing an ammonia dual fuel container ship. A consortium based in Japan has completed land-based testing of a four-stroke ammonia fuelled engine, which is planned to be installed on a tug in 2024. Swiss marine power company WinGD

is working on a dual fuel ammonia engine for ten 210,000 DWT bulk carriers for the Belgian ship-owner CMB (Latarche, 2023).

## Environment and climate

### Specific fuel consumption (SFC)

As the specific energy content per kg ammonia is only 18.6 MJ/kg compared to 42.7 MJ/kg for MGO, the SFC for an ammonia driven engine will be proportionally higher as follows (assuming the same engine efficiency as stipulated by (MAN Energy Solutions, 2023):

$$\text{SFC (ammonia 2 stroke engine)} = 42.7/18.6 \times 0.170 \text{ kg/kWh} = 0.390 \text{ kg/kWh}$$

$$\text{SFC (ammonia 4 stroke engine)} = 42.7/18.6 \times 0.190 \text{ kg/kWh} = 0.436 \text{ kg/kWh}$$

Taking into account that 5 % pilot diesel fuel is used for the combustion process, this small amount of diesel oil results in following SFC for an ammonia engine:

$$\text{SFC (2 stroke, ammonia engine + 5 \% diesel)} = 0.95 \times 0.390 \text{ kg/kWh} + 0.05 \times 0.170 \text{ kg/kWh} = 0.379 \text{ kg/kWh}$$

$$\text{SFC (4 stroke, ammonia engine + 5 \% diesel)} = 0.95 \times 0.436 \text{ kg/kWh} + 0.05 \times 0.190 \text{ kg/kWh} = 0.424 \text{ kg/kWh}$$

### Air pollution emissions

The emission profile of ammonia combustion engines is uncertain and highly depends on the type and amount of pilot fuel used.

The SO<sub>x</sub>, HC and CO emissions using ammonia are only related to the use of pilot fuel, which are taken into account proportionally with the 5 % pilot fuel.

No particulate emission data are yet available for engines operating on ammonia. However, PM emissions for methanol engines are also assumed valid for ammonia engines, where the influence of the pilot fuel is taken into account, which means that following emissions are assumed:

$$\text{PM (ammonia + 5 \% pilot fuel)} = 0.034 \text{ g/kWh} \times 0.95 + 0.27 \text{ g/kWh} \times 0.05 = 0.046 \text{ g/kWh}$$

NO<sub>x</sub> emissions formed by incomplete ammonia combustion are highly uncertain but higher than for conventional diesel fuel (Nadimi & et al., 2023). However, it is assumed that the compliance with Tier III regulations of NO<sub>x</sub> by the IMO has to be fulfilled. Existing and known NO<sub>x</sub>-reduction technologies used with fossil fuels can also be used for ammonia dual fuel engines, e.g. selective catalytic reduction (SCR) and exhaust gas recirculation (EGR) (Mærsk Mc-Kinney Møller Center, 2023).

### Greenhouse gas emissions

There are no CO<sub>2</sub> emissions from combustion of ammonia, meaning the only direct CO<sub>2</sub> emissions occur from the use of pilot fuel.

However, leakage of N<sub>2</sub>O (a greenhouse gas with a warming potential of the atmosphere that is 265 times that of CO<sub>2</sub> over a 100-year period) in larger amounts than from other engines is a concern (Mærsk Mc-Kinney Møller Center, 2023). No valid data exist for the potential leakage of N<sub>2</sub>O today, but the high combustion temperature in an ammonia driven

engine is expected to limit the emissions of N<sub>2</sub>O (European Maritime Safety Agency, 2022). According to research done in the industry, it seems to be possible to reduce N<sub>2</sub>O emissions to an extent where they will be negligible in the future. This uncertainty has to be solved in the future to give an accurate assessment of the greenhouse gas emissions from the technology (Førby & et al., 2023).

Besides the emission of GHG, ICE running on ammonia also have additional climate effects arising from emissions of black carbon (BC), also called soot particles. BC is not a greenhouse gas but is part of the particulate emissions formed by incomplete combustion (see page 25 under conventional diesel propulsion). However, the particulate emissions compared to ICE running on MGP/MDO are considerable lower.

### **Production sites**

Relevant shipyards involved in building the ammonia powered ships are in China, Japan, and Korea.

### **Prediction of performance and costs**

The technology is just about to emerge from Category 1 (“research and development phase”) to Category 2 (“pioneer phase”) (see Figure 1), with the first ships expected to be in operation in 2024. Compared to a conventional ICE, there are additional costs for an ammonia fuelled engine e.g. the dual fuel injection system and safety system, material selection and specialized fuel tanks. In the literature, it is mentioned that CAPEX could be up to 20 % higher than for a conventional vessel, with first-of-a-kind projects being 25 – 30 % more costly (Global Maritime Forum, 2023). These numbers are based on a gas carrier example and are assumed to be applicable for other ship types as well. The price is expected to decrease as the technology matures and becomes more commercially available.

A large part of the OPEX is the fuel cost itself, which will be significantly larger than for diesel oil. The high fuel costs can make costly investments worthwhile, which will improve the energy efficiency of ammonia over time. Due to high uncertainty about the magnitude, this is not quantified in the data sheets.

Due to the low energy density of ammonia, a ship will have to increase the bunkering frequency adding to costs compared to diesel. In an assessment of an ammonia fuelled gas carrier, fuel costs accounted for 80-90% of the additional annualized cost compared to a traditional carrier running on MGO (Global Maritime Forum, 2023). Regarding maintenance and labour, a dual fuel system has larger costs compared to a conventional ICE due to the higher complexity of the engines and fuel supply systems (Bui, Perera, & Emblemståg, 2022).

### **Uncertainty**

As the engines running on ammonia are not yet commercially available, there is a large uncertainty around several aspects of the technology. Security concerns, technical issues with the engine or fuel as well as ammonia slips in the engine are not yet observable in practice.

### **Additional remarks**

No additional remarks.

## **4.1. Container ships**

There is no information about container ships currently operating on ammonia, however, technically it can be possible.

Several companies report that they own “ammonia ready” ships or have these ships under construction. However, “ammonia ready” seems to refer to having two options in the future; both the possibility to retrofit the vessel with an ammonia system as well as with a methanol system.

## 4.2. Bulk carriers and tankers

There is no information about container ships currently operating on ammonia, however, technically it can be possible.

Several companies report having gotten delivered “ammonia ready” ships or having ships under construction. However, “ammonia ready” seems to refer to the option of installing an ammonia system later (retrofit) while also having the option to retrofit the vessel to methanol.

## 4.3. Ro-Ro cargo ferries

There is no information about container ships currently operating on ammonia, however, technically it can be possible. As Ro-Ro cargo ferries in addition to the crew only have a maximum of 12 passengers, the security concerns are lower compared to passenger ferries. Industry experts consider ammonia as an option for Ro-Ro cargo ships, which is why a data sheet is included.

# 5. Qualitative description – battery electric propulsion

## Contact information

Containing the following information:

- Contact information: The Danish Energy Agency, Ulrich Lopdrup, [ulo@ens.dk](mailto:ulo@ens.dk)
- Author: HOK Marineconsult ApS, Hans Otto Kristensen and COWI
- Reviewer: The Danish Energy Agency

## Description of propulsion technology and fuel

These ships rely on advanced battery technology as their primary power source, paving the way for zero-emission maritime operations. Harnessing the potential of batteries, these ships offer a clean alternative to conventional fossil fuel-powered ships, significantly reducing greenhouse gas emissions and air pollution. The battery electric propulsion system is illustrated in Figure 24. Battery electric systems directly convert electro-chemical energy in batteries to mechanical power in an electric motor, which has a higher overall energy efficiency, achieving efficiency ratings above 90 %, while ICEs can operate at up to 50 % efficiency. Battery electric systems are commercially ready for certain ship types, most notable passenger ferries up to 11,000 GT (IMO, 2023).

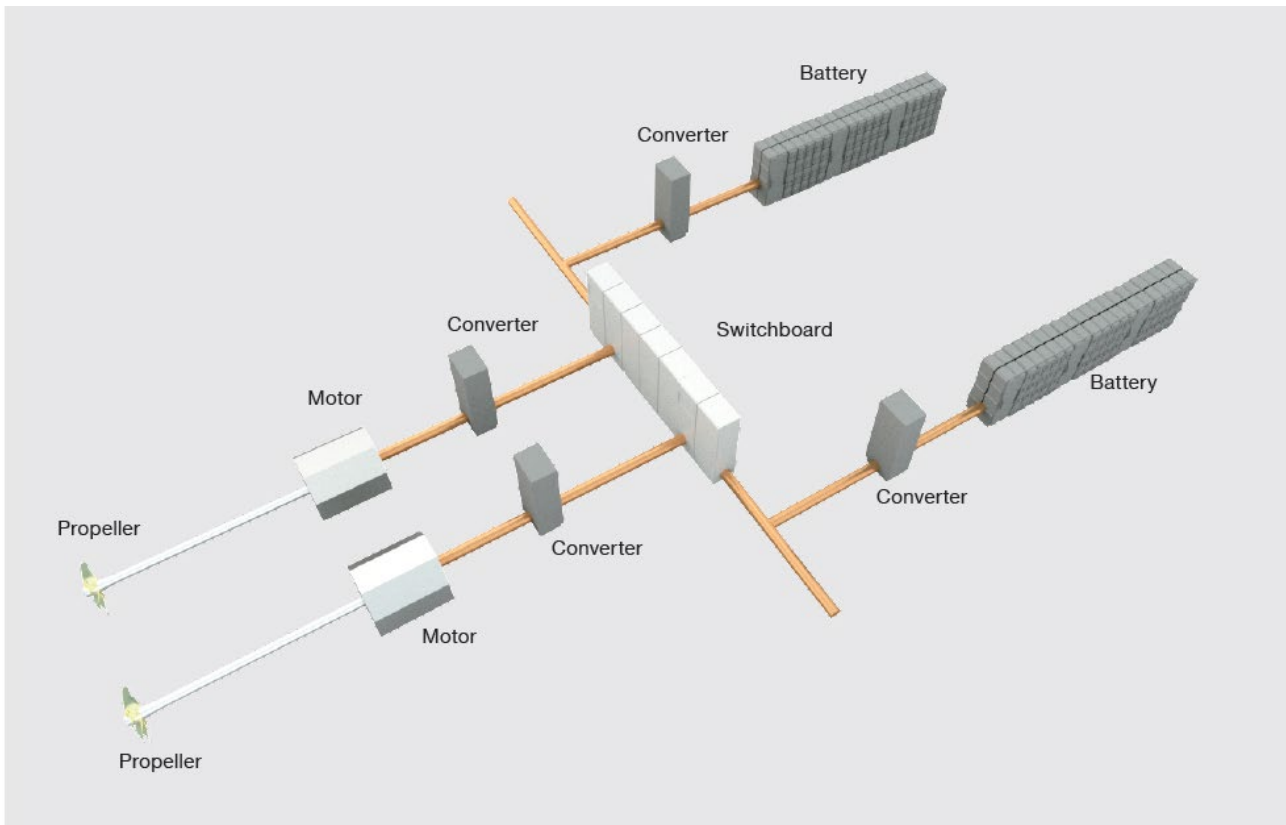

**Figure 24 Battery-electric propulsion system (MAN Energy Solutions, 2019)**

The energy density of batteries is currently the primary challenge due to high weight when the sailing distance is long. For lithium-ion batteries, the normal Stage of Charge (SoC) is typically between 20 % and 80 %. It is recommended to avoid fully depleting or fully recharging the battery to maximise its lifespan (Davies & et al., 2019). Therefore, only approximately 60 % of the electric energy in batteries can be utilized before recharging is necessary. This can be different for other battery types, which are under development.

The main power source for modern electrical ferries is batteries, but in case of battery failure the ferry will not be able to sail and manoeuvre safely. Therefore, electrical ferries are increasingly equipped with a diesel-electrical power supply, which can act as an emergency back-up solution in such cases. Fuel tanks are therefore necessary for supplying diesel generators. The fuel tank and diesel generators are not reflected in the data sheets.

### Advantages/disadvantages

Electric motors are a known technology and there are examples of fully battery electric ferries. There is a full reduction of emissions during use.

OPEX is low due to high efficiency of the electric motor and the favourable electricity prices compared to e-fuels.

CAPEX can be high depending on the size of battery pack. Further, batteries must be replaced during the ship lifetime causing additional investment costs.

The energy density of batteries is currently low, which means that battery packs are heavy and reduce the payload of a ship significantly when the sailing distance is long. This makes the technology unfeasible for large ships sailing long distances.

The charging time when ships are in port can conflict with the conventional schedules.

A sufficient charging infrastructure must be secured, which is both costly and can lead to challenges in the local electricity grid.

### **Bunkering or charging infrastructure**

Integrating infrastructure to support electric ferries and ships into existing power grids necessitates overcoming infrastructure challenges and grid capacity limitations. This includes substantial upgrades to the grid and the implementation of efficient charging infrastructure.

Examples of existing charging infrastructure, in Denmark, is the Elsinore – Helsingborg route, where robots at the two harbours automatically connect the ferries to the grid, when the ferries arrive. The operator reports that the charging infrastructure operates with 10.5 MW and that a charging time of 7 to 9 minutes is sufficient for the crossing of 2.5 nautical miles. Scandlines is currently building charging infrastructure in Rødbyhavn with a 50 kV / 25 MW cable to support their upcoming electrical ferry between Rødby and Puttgarden.

### **Interaction with the energy system**

Battery electric ships have a direct interaction with the energy system as their “fuel” is electricity stored directly from the grid. Integrating electric ships into the energy system may present notable challenges, as the power demand is large and not flexible during service hours.

Ferries operate with tight schedules and other ships face larger costs the longer time they spend in port. Therefore, the charging needs for ships require a large power supply in a short period time when they are in port. Time schedules for especially ferries are not flexible, hence the point of time when charging is needed is highly inflexible. The charging patterns could potentially necessitate grid upgrades to handle increased loads, and at the same time pose challenges for balancing of the energy system.

Balancing the load on the grid and ensuring uninterrupted power supply to both vessels and the onshore grid could maybe be mitigated partly, by encouraging battery charging during off-peak hours when possible or by the ports having alternative sufficient energy storages. However, these facilitations might not be neither viable nor economically feasible.

### **Current market and technological status and future development perspectives**

Examples of ships with electric motors and battery storage are 4 ferries currently operating in Denmark:

- TYCHO BRAHE: Helsingborg – Elsinore. Fully-electric after retrofit in 2018
- AURORA: Helsingborg – Elsinore. Fully-electric after retrofit in 2018
- ELLEN: Søby – Fynshav, 2019
- GROTT: Esbjerg – Fanø: 2021

Other countries, which have deployed battery-electric ferries on several short routes, are Norway and Sweden. The Norwegian government has requirements stating that all new ferries and fast ferries shall be low- or zero-emission

within the coming years. The development in the number of battery-electric ferries shows that there is a trend in deploying the technology for the segment of ferries.

The newest batteries deployed for maritime use have an energy density around 6 tonnes per MWh, which makes batteries heavy, compared liquid fuels. Especially for longer distances, where energy needs are high, the battery weight will increase to an amount which makes the technology unfeasible at the current stage. The battery capacities and energy density of batteries currently used in the 4 ferries operating in Denmark are illustrated in Table 3, which shows that there has been a positive development in the energy density over the last years. The sailing distances between charging for these ferries vary between 3 to 20 nautical miles.

**Table 3 Battery data for ferries with battery-electric propulsion operating in Denmark**

Ferry	Battery	Weight	Capacity	Energy density
		tonnes	kWh	kg/kWh
<b>TYCHO BRAHE (1. generation batteries)</b>	SPBES (SHIFT)	57.0	4,160	13.7
<b>TYCHO BRAHE (2. generation batteries)</b>	Corvus Dolphin	52.0	6,345	8.2
<b>AURORA af Helsingborg (1. generation batteries)</b>	SPBES (SHIFT)	57.0	4,160	13.7
<b>AURORA af Helsingborg (2. generation batteries)</b>	SPBES (SHIFT)	69.7	4,800	14.5
<b>ELLEN</b>	Leclanché	54.3	4,401	12.3
<b>GROTTE</b>	Corvus Orca	15.23	1,107	13.8

Sample calculations for ferries (except catamaran ferries) show weight challenges of batteries are counteracted due to a reduced main propulsion machinery weight (no or smaller fuel tanks and lighter motors) for a crossing time of approximately one hour. Therefore, mentioned negative consequences of batteries can be disregarded for ferries serving relatively short routes.

In comparison, systematic calculations for container ships show that the weight of batteries for 24 hours sailing will correspond to 14 - 25 % of the deadweight, meaning that with less than one week of sailing the necessary battery weight will be equal to the entire deadweight. In the current state this clearly shows that electric powering of deep-sea cargo ships is impossible, as shown in Table 4 for container ships. The situation will be the same for tankers and bulk carriers.



**Table 4 Illustration of battery weights if used on container ships**

<b>Ship size (TEU)</b>	<b>Weight of batteries for one day sailing in pct. of deadweight</b>	<b>Number of possible sailing days on batteries having the same weight as the total deadweight</b>
<b>1,000</b>	25.0	4.0
<b>5,000</b>	19.5	5.1
<b>10,000</b>	18.6	5.4
<b>15,000</b>	15.8	6.3
<b>20,000</b>	14.5	6.9
<b>25,000</b>	14.0	7.1

Battery suppliers, research literature and experts from the Technical University of Denmark expect the observed trend in improved energy density in batteries to continue in the future. Taking uncertainties into account, a reduced weight to 5 kg/kWh is expected in the period 2025 - 2030, with further battery weight reductions to be expected after 2030.<sup>10</sup> It is not possible to present a reliable forecast based on the literature, however, a lower weight of 2 kg/kWh is under high uncertainty assumed to be developed by 2050.

### **Environment and climate**

The battery- electric propulsion system does not have any direct emissions of greenhouse gases or air pollutants during use. There are currently emissions from the production of electricity, which are not included in the scope of this catalogue.

However, there will be indirect emissions related to the production of the ship and the batteries, which are significant and should be included when doing a life-cycle-assessment of emissions related to a battery-electric ship. The battery packs are expected to have a shorter life span than the ship, why battery replacement must be taken into account when assessing the life cycle emissions.

Production sites for electrical ferries can be Denmark, like Hvide Sande Shipyard where Grotte was built, but for larger ferries shipyards in Turkey seem to be more relevant in the future, where e.g. two battery electric ferries for Molslinjen and 1 battery electric ferry for Scandlines are currently being build.

### **Prediction of performance and costs**

The technology is in Category 3 level of maturity (“commercial with moderate deployment”) in Figure 1. Due to the development of several parameters like energy density and price, the technology is already deployed on small ferries

---

<sup>10</sup> Professor at DTU (Technical University of Denmark), Section Power-to-X and Storage at the Department of Wind and Energy Systems.

or ferries with short sailing routes, whereas it is expected to first become feasible for larger ferries/longer routes in the future.

The CAPEX of battery electric propulsion systems contains among other things the following two parts. Firstly, the battery for electricity storage, which presently is a costly component. Secondly the motor, which compared to a conventional ICE has lower costs due to a simpler design and fewer moving parts. It depends on the ship type, whether a cost increase or decrease compared to diesel combustion propulsion systems can be expected.

Costs for battery electric propulsion systems are expected to decrease over time as the technology advances and economies of scale effects due to larger units produced.

In addition to an increase in the energy density of batteries, the literature is predicting a drop in battery prices. Bloomberg and the International Energy Agency IEA have published prices of around 150 USD/kWh for year 2022 and 2023 and Bloomberg predicts prices to fall below 100 USD/kWh by 2026. In the technology catalogue for energy storage (Danish Energy Agency, 2018) a price of 70 USD/kWh is predicted for 2030 decreasing to 50 USD/kWh in 2040 and 40 USD/kWh in 2050, using a 18 % learning rate and the predicted capacity growth.

Higher battery prices are depicted by producers of batteries for use in electric ferries. Current battery prices for marine usage from suppliers are around 300 - 500 USD/kWh for lithium-ion batteries. Taking the necessary electronics for the installation of the battery pack into account, the price is around 550 - 700 USD/kWh. The suppliers also note, that LFP (Lithium- Iron Phosphate) batteries, a sub-category of lithium-ion batteries using iron phosphate, are starting to be used in the maritime sector and can be approximately 100 USD cheaper per kWh. They are also more durable than current commercial battery options. The suppliers also confirm that a price reduction of 3 – 5 % per year is expected in the medium to long term.

Due to a relatively low lifetime of batteries, they are expected to need replacement within the ship's lifetime, increasing CAPEX. However, suppliers state that e.g. a cell swap solution can extend the battery design lifetime to match the ships lifetime. Here the individual cells are replaced with new ones, while the other equipment remain unchanged, which can reduce the costs of battery replacement. Due to high uncertainty about the development of battery lifetime in the future, the value is kept constant in the data sheets.

OPEX are primarily driven by fuel costs. Electricity costs vary and have been both lower and higher compared to diesel. The cost for electricity is lower than the total cost of e-fuels using electricity as input (hydrogen, methanol and ammonia production uses 1.5-5 times the amount of electricity for one kWh energy output compared to direct electrification). Maintenance and repair of a battery electric system is lower, as the system is much simpler than an ICE (e.g. less moving parts, no need for lubrication oil). However, due to the need for a backup system with a diesel generator, the cost savings can be small.

### Uncertainty

There is great uncertainty about the development of battery technologies both in terms of chemistry and energy density. Both aspects are crucial for making the battery technology technically feasible for larger ships/longer distances. There is also substantial uncertainty about future costs of battery technology. Besides the actual price of batteries the development in battery lifetime also heavily impacts operating costs. As an example the introduction of LFP (Lithium Iron Phosphate) batteries seems as a cheaper and more durable alternative to the Li-NMC (lithium nickel manganese cobalt oxides) batteries, which is currently the most used chemistry in the marine sector. LFP batteries have lower

energy density but longer lifetime / more charging cycles. It is therefore unclear to what extent marine battery electric propulsion systems in the future will be competitive with alternative technologies.

Finally, technical problems have been observed for some battery electric ferries operating in Denmark showing the risks related to the introduction of new technologies.

#### **Additional remarks**

Due to the current state of energy density for batteries and uncertainties regarding future development, no data sheets are developed for battery-electric propulsion of ocean-going vessels with large energy needs, where propulsion technologies using ammonia or methanol fuels are more developed and feasible alternatives to reduce emissions. Furthermore, no data sheet for high-speed catamaran ferries is included, due to the high uncertainty whether future batteries can solve the challenges of high weights of the battery pack and necessary speed reductions, see section 5.2.

### **5.1. Ro-Ro cargo ferries**

Calculations for Ro-Ro ships reveal that battery propulsion is only possible for ferry routes of maximum 2 – 3 hours, and with one hour sailing the weight of the battery will correspond to approx. 10 pct. of the deadweight. This means that after 9 – 10 hours sailing the entire deadweight has to be dedicated batteries.

TYCHO BRAHE and AURORA are operating on the short 2.5 nautical mile route between Denmark and Sweden and have battery capacities of 4.8 – 6.3 MWh (see Table 3).

Two double ended hybrid ferries on the 11 nautical miles route between Rødby and Puttgarden are planned to be fully electric in the future. A battery electric Scandlines ferry is currently being built with a 10 MWh battery energy storage system and is expected to enter service in 2024.

For longer routes such as Hirtshals-Kristiansand (71 nautical miles) the battery size becomes more critical, with a battery capacity of more than 100 MWh (weighting more than 1,000 tonnes – equal to more than 40 % of the payload for a 1,600 passenger Ro-Ro ferry). For the Copenhagen-Oslo route (approx. 300 nautical miles) the needed battery capacity would be more than 400 MWh, with a weight of more than 4,000 tonnes which makes it impossible to use a battery powered ferry on that route with the current battery technology.

For Ro-Ro passenger ferries it is assumed, that the price of a battery electric ferry at present will be approximately 20 % higher than for a conventional diesel driven ferry, as the overall complexity of the machinery arrangement will be more complicated due to an ICE supported backup in case of failure of the battery system. The price difference will decrease over time as battery costs decrease and the technology will be more widespread.



Figure 25 The battery-electric ferry Aurora operating the 2.5 nautical mile route between Elsinore, Denmark, and Helsingborg, Sweden (Courtesy of ForSea)

## 5.2. Fast ferries

The energy density of batteries is currently too low to be a feasible solution for fast ferries in Denmark. With current technologies, the Molslinjen fast ferries would need a 550 tonnes battery pack on the 40 nautical miles route Aarhus-Odden, significantly reducing the number of cars that can use the fast ferry.

The Australian shipbuilder Incat Tasmania has announced, that they are building a 130 m long battery electric catamaran ferry for Buquebus, which will be used on a 40 nautical miles route between Argentina and Uruguay. Even though the ferry is around 20 meters longer than Express 5 on Bornholmslinjen, the 40 MWh battery pack only leaves space for transporting 2,100 passengers and crew as well as 225 cars, which is half the cars capacity of Express 5. Furthermore, the Incat catamaran will operate at around 23-25 knots, which is a significantly lower speed than what is required of a fast ferry according to the IMO High Speed Craft Code. It makes this an unfeasible solution in the Danish context, where fast ferries need to provide a feasible alternative to the route between Zealand and Jutland over Funen by car.

Due to the weight and reduced transportation capacities as well as challenges with speed and uncertainties about the future developments of batteries, no data sheet for battery electric high-speed catamaran ferries is included in the catalogue. It might be an alternative in the future and can be further assessed as the battery technology progresses.

## 5.3. Small ferries

Examples of small ferries with a battery electric propulsion system in Denmark are Ellen and Grotte. Battery weights are not an issue, as they operate on short routes.



**Figure 26** The battery electric ferry *Grotte*, operating the 1.35 nautical mile route between Fanø and Esbjerg (Courtesy Fanoelinjen)

The CAPEX of battery electric small ferries is observed to be slightly higher than for conventional small ferries (see section 7.5). Within the next years, the cost difference is expected to be minimal, as the technology becomes more widespread and a standard in shipyards.

## 6. Qualitative description – fuel cell propulsion

### Contact information

Containing the following information:

- Contact information: The Danish Energy Agency, Ulrich Lopdrup, [ulo@ens.dk](mailto:ulo@ens.dk)
- Author: HOK Marineconsult ApS, Hans Otto Kristensen and COWI
- Reviewer: The Danish Energy Agency

### Description of propulsion technology and fuel

Hydrogen fuel cells utilize hydrogen to produce electricity through an electrochemical reaction. Emitting only water vapor as a by-product, this technology offers the hydrogen as a sustainable and carbon-neutral fuel. A fuel cell marine

propulsion system consists of a fuel cell stack consisting of multiple individual fuel cells, converting hydrogen into electricity, powering the electric motor driving the propellers. The system also features a temporary power storage device, typically a battery, which allows for a time lag between the generation and consumption of power (see Figure 27).

Fuel cell stacks are designed to be modular, meaning that they can be connected in series or parallel to achieve the desired power output and can be scaled up or down.

Hydrogen is carried on board in gaseous or liquefied form requiring high-pressure tanks or double-walled, vacuum-insulated tanks to maintain low temperatures required for the liquid form.

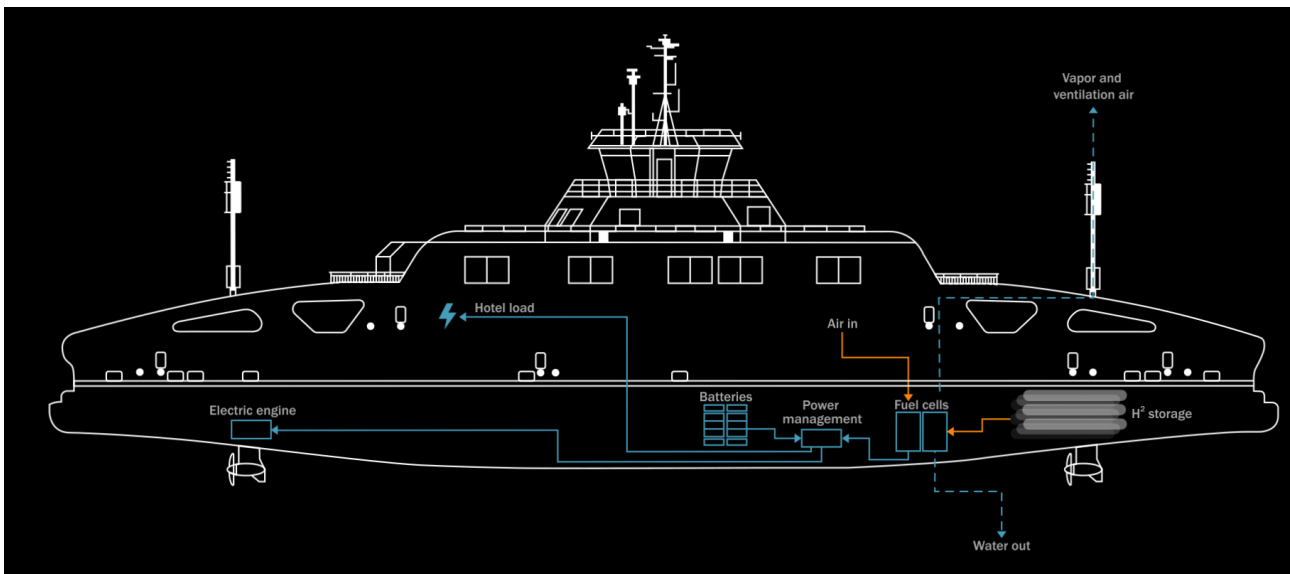

Figure 27 Fuel cell propulsion system with hydrogen (Courtesy Ballard Power Systems)

### Advantages/disadvantages

From the on board hydrogen fuel cells, the only exhaust product is water, thus the technology is considered to be a “zero emission” technology. From a system perspective it is however dependent on the use of green hydrogen.

On board fuel cells electric systems have a higher energy conversion efficiency compared to ICEs, but significantly lower compared to battery electric systems caused by the conversion step from hydrogen to electricity in the fuel cell.

Fuel cells are modular, which allows for more flexibility in the ship design which can contribute to a more optimal weight distribution.

Fuel cells have few moving parts compared to an ICE, which can reduce maintenance costs and downtime (Pratt, 2022).

The energy density of hydrogen (2.5 MJ/litre compressed and 8.5 MJ/litre liquefied hydrogen, see also Table 6) is around four to 15 times the volume of MGO, requiring larger and more complex fuel tanks, e.g. with high-pressure and cryogenic cooling methods. The weight and volume will be significantly larger than for methanol and ammonia, practically making

it an unfeasible solution for larger merchant ships. Furthermore, fuel cells are currently large, presenting challenges for larger ships and longer distances due to volume and weight concerns.

Hydrogen has a wider flammable range, a higher reactivity and a lower ignition energy, which is why the explosion risk and safety aspects are of higher concern than for e.g. diesel oil and methanol.

### **Bunkering or charging infrastructure**

Hydrogen must be transported and stored at a very low temperature (- 253°C) or at high pressure (800 bar).

There is no standard for marine bunkering of liquid or compressed hydrogen, even though several bunkering locations exist. Hydrogen is transferred to a ship from shore using a pipe or hose.

The bunkering time is about 3,000 kg/hour for liquid hydrogen and 220 kg/hour for compressed hydrogen, which is why compressed hydrogen refuelling is sometimes conducted by swapping fuel tanks. Examples of bunkering locations for compressed gaseous hydrogen are in Belgium, the Netherlands, Tokyo and San Francisco. Liquid hydrogen transfer to a ship is currently available in three locations. The facilities in Kobe, Japan and Hastings, Australia are fixed infrastructure including storage tanks while the bunkering system in use for the MF Hydra in Hjelmeland, Norway is a mobile system designed for use on any quayside and uses liquid hydrogen delivered by truck. With a loading rate of 3 tonnes per hour, it takes about 1 – 1.5 hours to bunker MF Hydra's 5.8 tonnes storage capacity, which is an argument against using hydrogen as fuel (IMO, 2023).

### **Interaction with the energy system**

Hydrogen production through electrolysis, powered by renewable sources, is key to enable a sustainable use of hydrogen. To realize its potential new infrastructure is crucial, particularly for large-scale uses like maritime transport. Ships, requiring substantial hydrogen, necessitate nearby production facilities, efficient transportation, and reliable on-site storage.

The demand for electrolysis required to support PtX-processes will potentially challenge both the renewable energy production and the grid infrastructure, as it may demand more renewable energy than what is accessible at a given point in time, as well as pushing the limits of the grid. However, by utilizing excess renewable energy during off-peak periods, electrolysis can store renewable energy in the form of hydrogen for e-fuels, such as methanol. Consequently, whether electrolysis will constrain or benefit the grid operation will depend on how it is run. The ability to run flexibly, combined with great sensitivity of electrolysis production to the electricity price means that the electrolysis plant is expected to respond to incentives and to act with flexibility in relation to the electricity system. Because of this ability to be flexible, PtX also has a potential to reduce some of the challenges that exist associated with the future increasing need for network reinforcements, as well as the challenges of ensuring the long-term security of electricity supply.

### **Current market and technological status and future development perspectives**

Challenges for a wide deployment of fuel cells in shipping are the volume and weight of fuel cells. An example is the Norwegian ferry MF Hydra, 82 meters long with a capacity of 299 passengers and 80 cars (HANSA, 2023a). Only around 20 % of the ferry's energy usage is provided by two 200 kW Ballard fuel cells (weighing 1 tonne each) and the remaining power comes from a 1.35 MWh battery.

The small ferry Sea Change with a capacity of 75 passengers and is supposed to operate in the San Francisco Bay within 2024, has slightly larger 360 kW fuel cells (Switch, 2023) developed by Cummins. Other sources state, that the fuel cell

is comprised of three smaller fuel cells of 120 kW each (State of California, 2023), which is why there is uncertainty about the technological status.

Several projects developing hydrogen solutions for larger ships and routes for smaller ferries in e.g. Norway and Denmark have been announced. Public announcements of hydrogen fuel cell systems to reach final investment decisions show that two systems with 6.5 MW capacity are expected to be installed before October 2025 for main propulsion on Ro-Ro passenger ferries (IMO, 2023).

### Environment and climate

Hydrogen fuel cells emit no greenhouse gases or emissions other than water vapour. From a system perspective emissions occur in the hydrogen production and is therefore highly depended on the energy source used. These upstream emissions are however outside the scope of this catalogue.

### Prediction of performance and costs

Based on the literature, the cost of fuel cells for maritime applications ranges between 500-1,200 USD/kW. Including the capital costs for the whole propulsion system (e.g. batteries, H<sub>2</sub> tank, auxiliary equipment and electric motor) it is ranging between 2,400 - 3,400 USD/kW. Prices for fuel cells will decrease with increasing system size and larger production volumes. Fixed OPEX are found to be 5 % of CAPEX (Elkafas, Rivarolo, Gadducci, Magistri, & Massardo, 2023)

Maintenance and repair of the system is lower compared to an ICE, as the system is much simpler (e.g. less moving parts, no need for lubrication oil). There is no precise knowledge on the lifetime of fuel cells, however, the batteries installed in the propulsion system will have to be replaced during the ship's lifetime, increasing OPEX.

The level of maturity (Figure 1) is still in Category 1 ("research and development phase"), entering Category 2 ("pioneer phase") for small ferries. This makes the parameters for the technology and developments in the future quite uncertain.

### Uncertainty

Fuel cells and hydrogen have not really been tested on ships as the only propulsion power so far, giving uncertainties on how the technology will perform. The size (volume) and weight of fuel cells as well as the slow bunkering time and the developments thereof in the future are uncertain and barriers to adopting the technology on a larger scale.

### Additional remarks

Fuel cells used in shipping today are very small and examples of a small ferry fully operated on only hydrogen has yet to be seen. Therefore, no data sheet is developed in this catalogue.

## 6.1. Small ferries

There is no ferry fully based hydrogen fuel cell propulsion in commercial operation yet. As described above, the small ferry Hydra in Norway only gets 20% of propulsion from a hydrogen-based system. The small catamaran passenger ferry Sea Change is planned to operate in San Francisco and is currently undergoing trials. The vessel has a 360 kW PEM fuel cell, hydrogen storage tanks with a capacity of 246 kg and is integrated with a 100 kWh lithium-ion battery. Two 300kW electric motors provide the electric propulsion. The design originates from Incat.





Figure 28 Sea Change (Courtesy Switch)

## 7. Quantitative description

This chapter is outlining data sources and assumptions behind the data sheets.

### 7.1. Documentation of central assumptions behind the data sheets

The simulations were conducted in the publicly accessible modelling software SHIP-DESMO.

As described ships are generally very complex and varies considerably even for each ship type due to the large variations in size and individual construction. In order to solve this problem some generic computer models have been developed at DTU from 2015 to 2018, under the name SHIP-DESMO, which include specific generic calculation models for following ship types:

- Container ships
- Bulk carriers
- Tankers
- Ro-Ro cargo ships and
- Ro-Ro passenger ships

Since model completion in 2017, it has been used by many different experts, companies and authorities (e.g. the United States Environmental Protection Agency and in work related to the IMO). It has been extensively tested against data of real ships, and a very good agreement between the theoretical values obtained by using SHIP-DESMO compared to actual ship observations has been observed. In this way the different ship models have been indirectly benchmarked. All the reports describing the different SHIP-DESMO models are shown in the reference list. These reports and the SHIP-DESMO models can be downloaded from following link at DTU's homepage: (DTU, 2023) <sup>11</sup>

## 7.2. Technical parameters

The graphs below illustrate the background data for different ship types, which are the foundation of the technical parameters presented in the data sheets.

### Container ships

Below the data points for container ships are illustrated in various graphs. The data points are part of the source material for the data sheets.

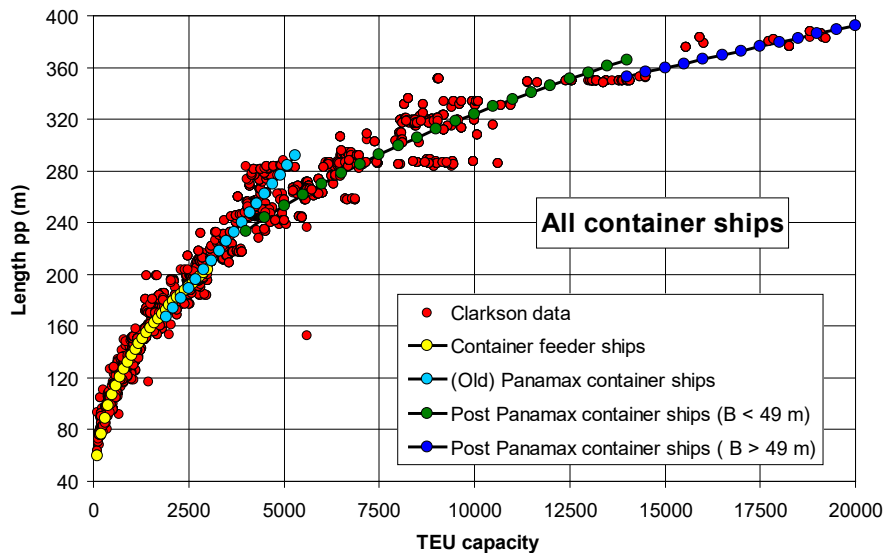

Figure 29 Length between pp, Lpp, as function of the container ship capacity

<sup>11</sup> See also <https://gitlab.gbar.dtu.dk/oceanwave3d/Ship-Desmo>

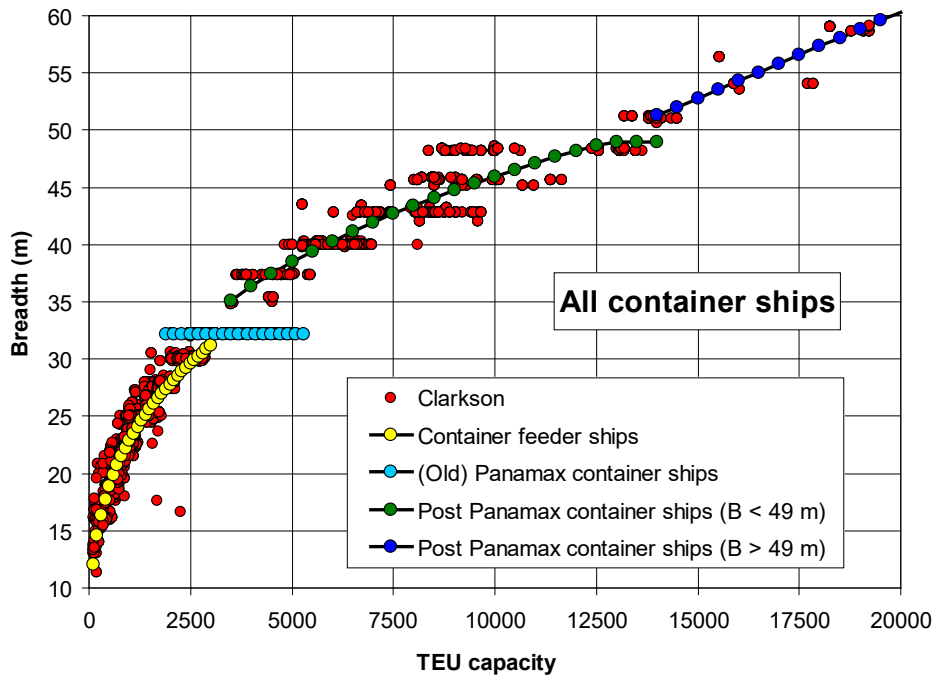

Figure 30 Breadth as function of the container ship capacity

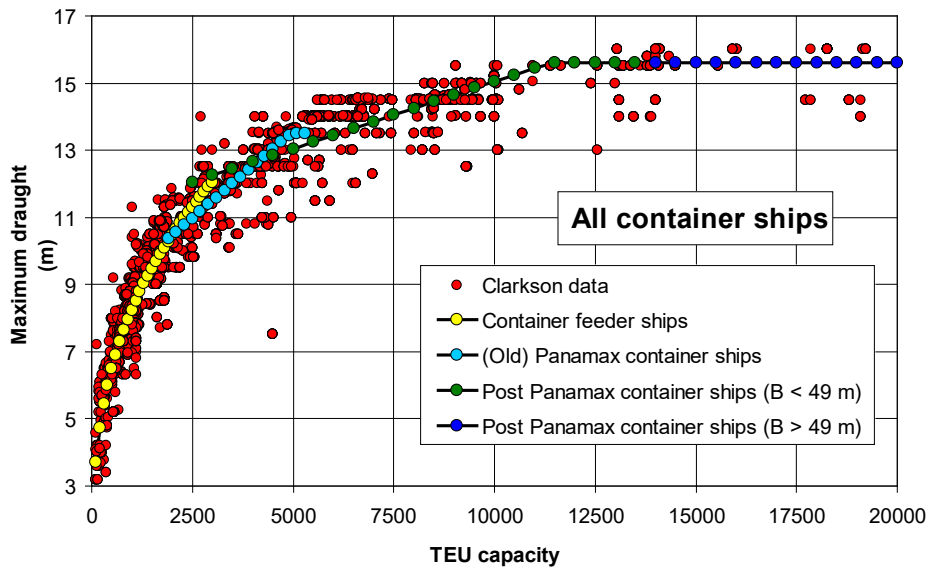

Figure 31 Maximum draught as function of the container ship capacity

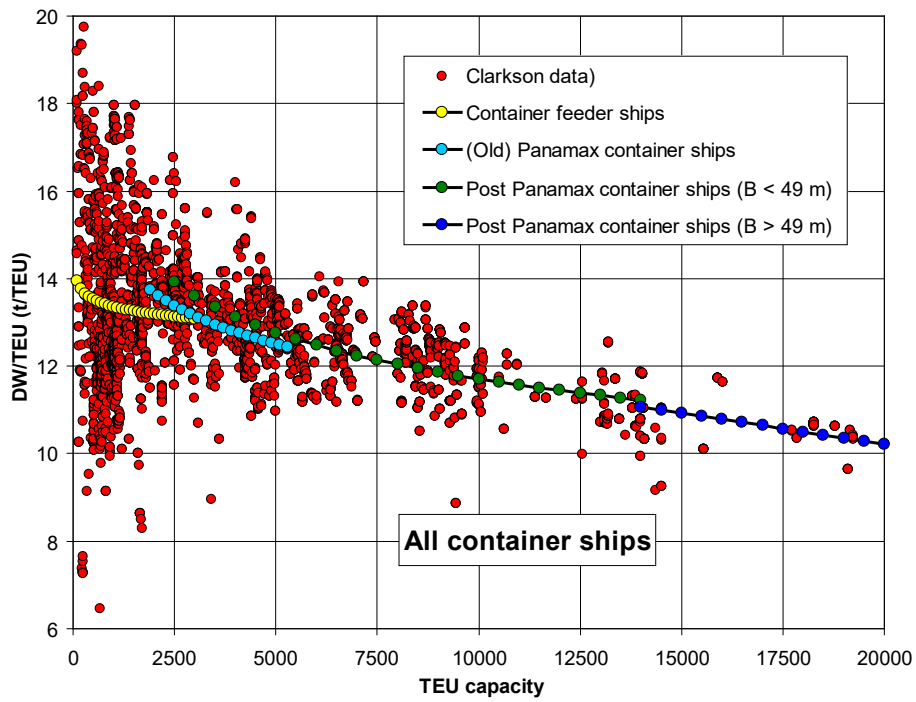

Figure 32 Average deadweight per TEU as function of the container ship capacity

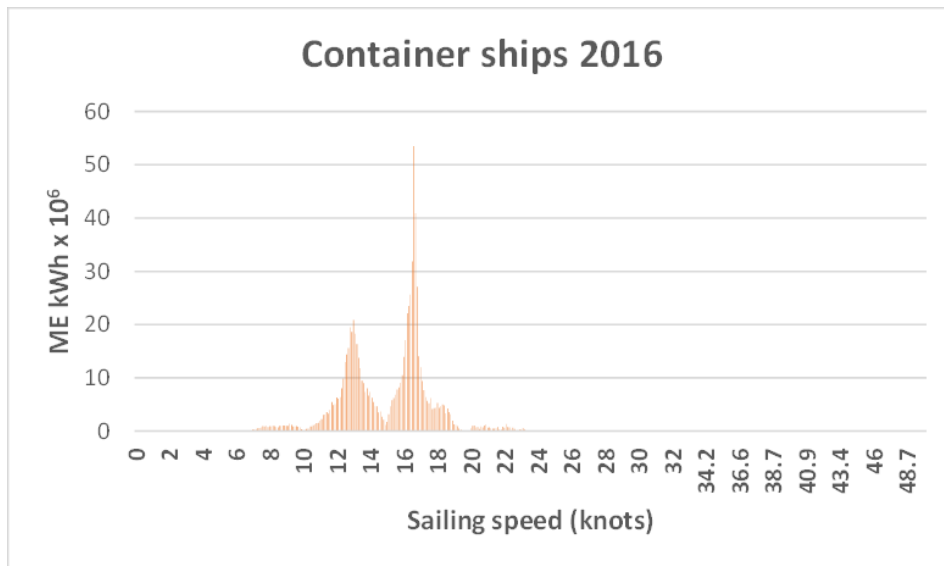
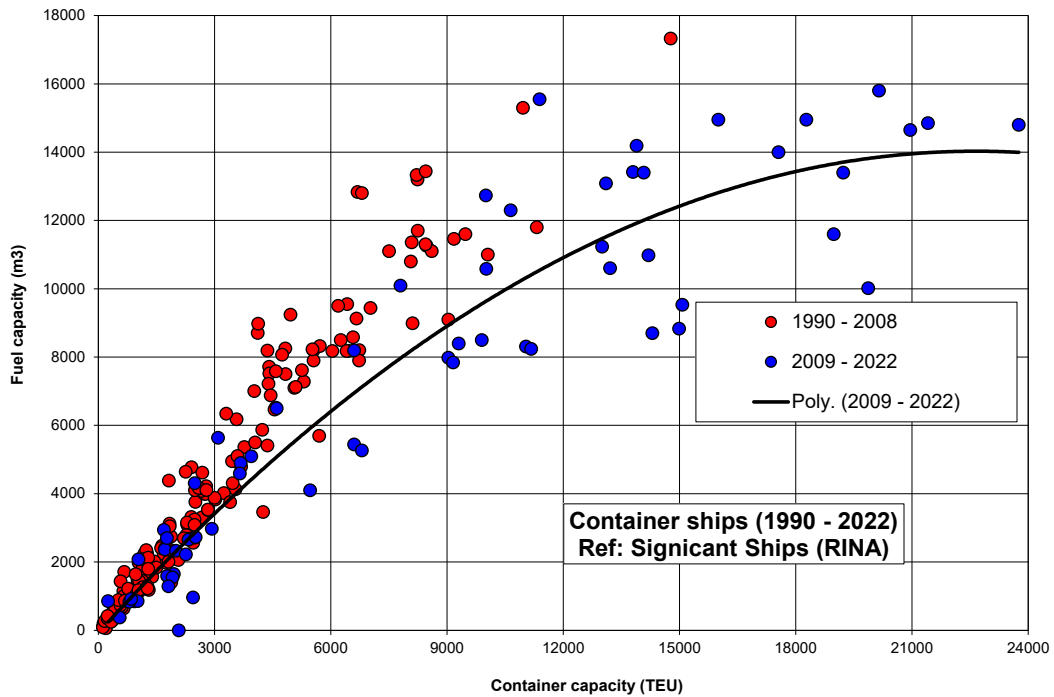

Figure 33 Histogram of typical container ship speed measured by peak energy usage

The volume of bunker fuel tanks is shown in Figure 34 and can be expressed as follows:

$$\text{Volume of oil tanks} = -0.00002754 \times \text{TEU} + 1.24636 \times \text{TEU} - 77.7$$



**Figure 34 Bunker volume as function of the container ship capacity in TEU**

### Bulk carriers and tankers

Below the data points for bulk carriers and tankers are illustrated in various graphs. The data points are part of the source material for the data sheets.

The general hull dimensions and the maximum service speed are presented in Figure 35 - Figure 42 showing the similarity between bulk carriers and tankers.

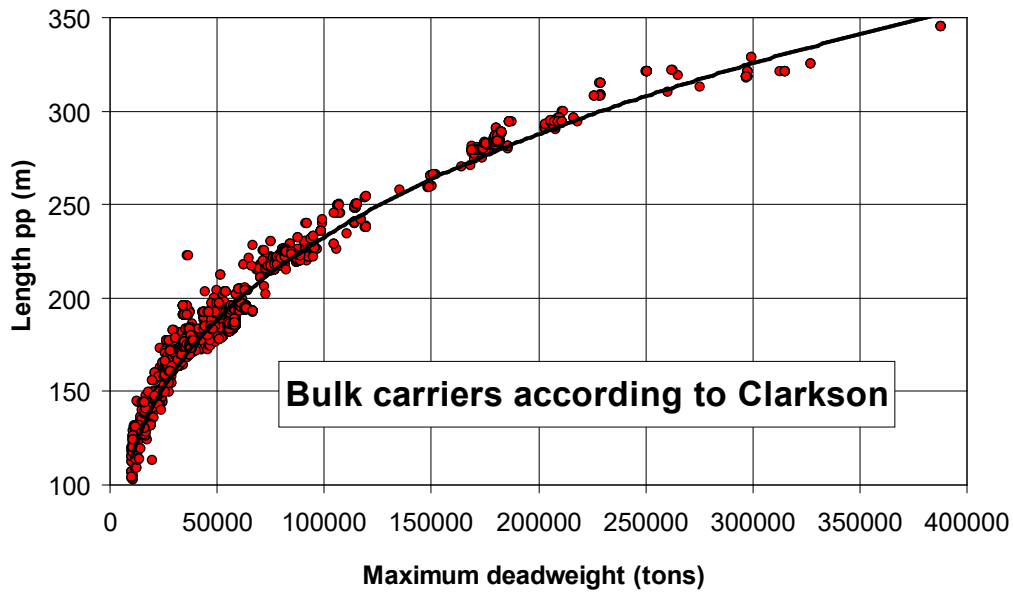

Figure 35 Length between pp, Lpp, as function of bulk carrier deadweight

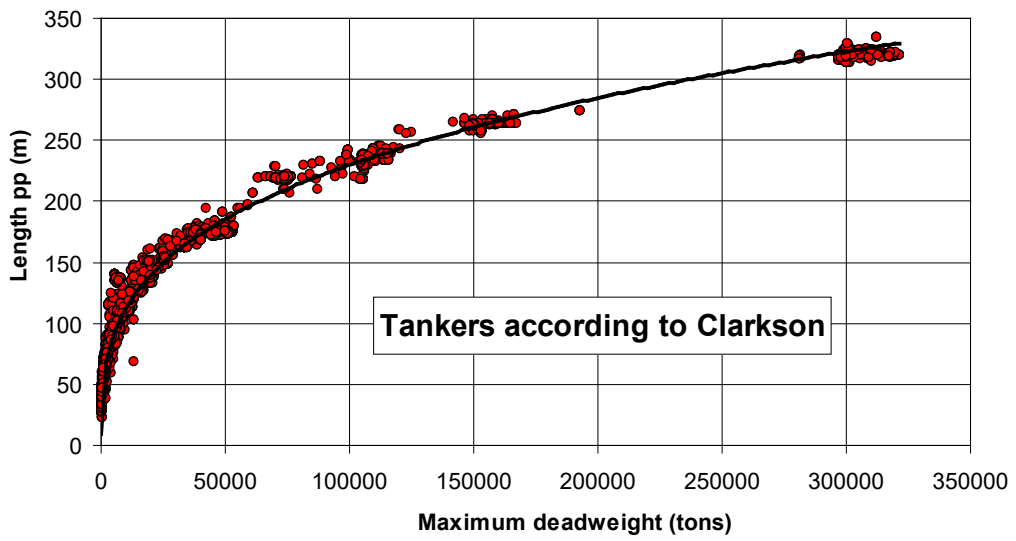

Figure 36 Length between pp, Lpp, as function of tanker deadweight

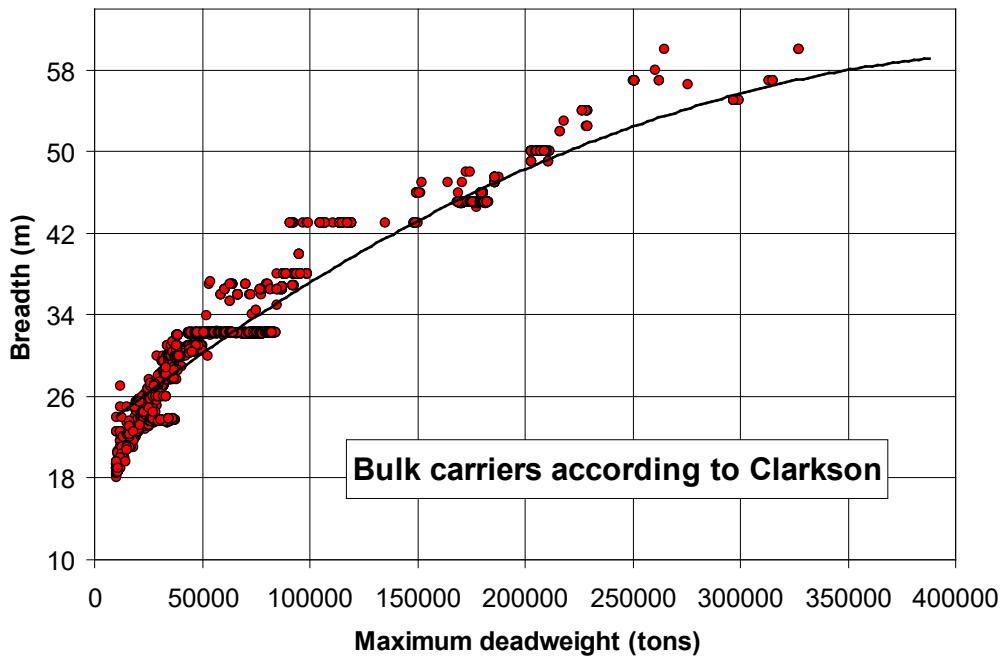

Figure 37 Breadth as function of bulk carrier deadweight

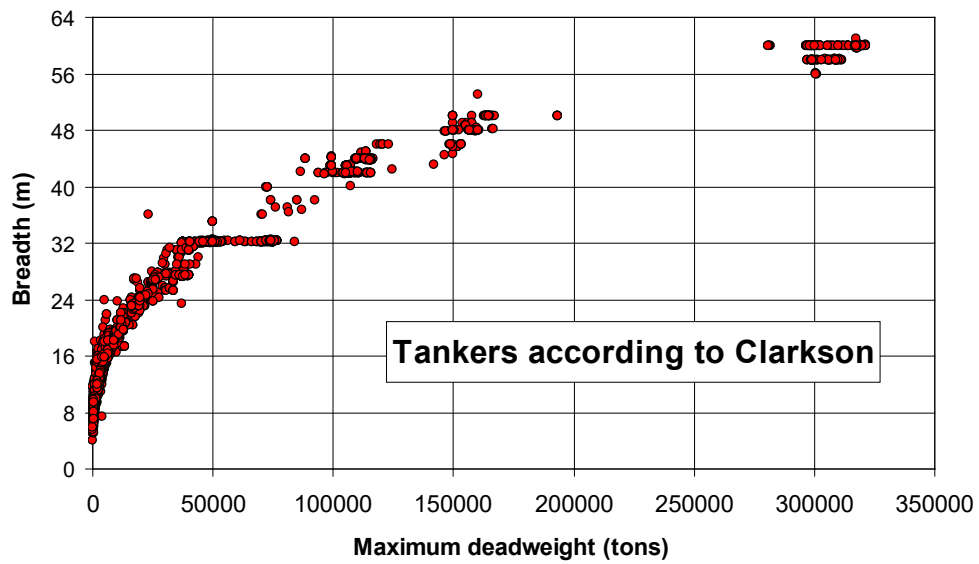

Figure 38 Breadth as function of tanker deadweight

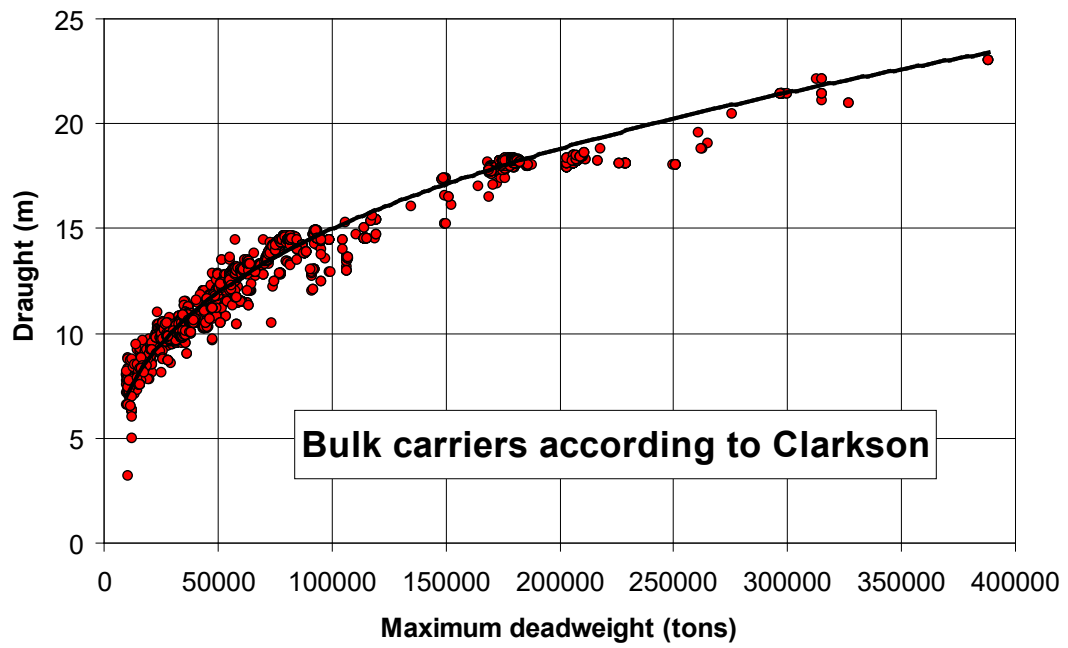

Figure 39 Maximum draught as function of bulk carrier deadweight



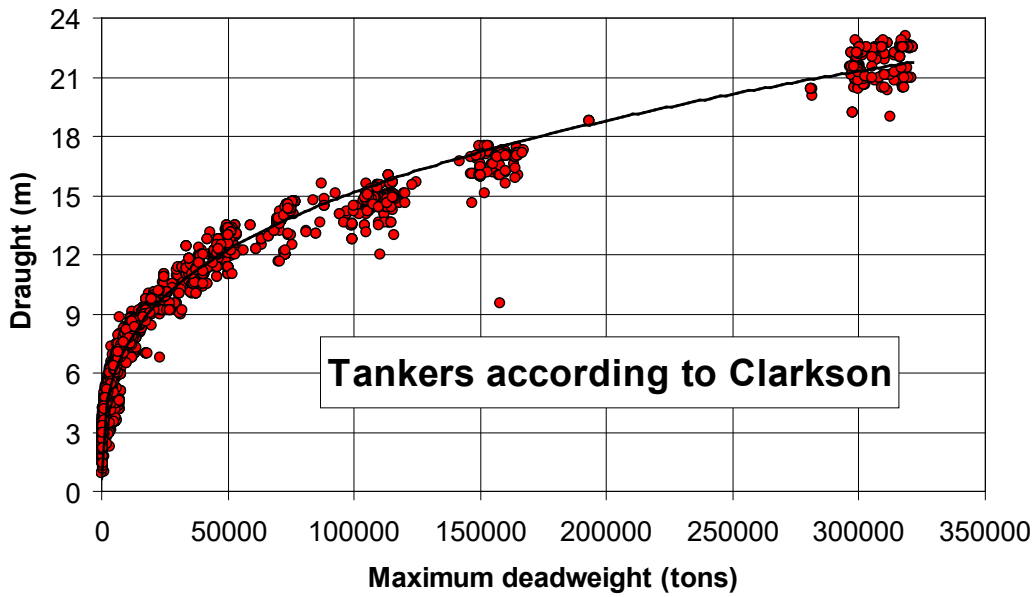

Figure 40 Maximum draught as function of tanker deadweight

For the two ship types following maximum service speed has been determined:

$$\text{Speed} = \text{MIN}(15 ; 9.5 \cdot \text{DWT}^{0.043}); \text{ if DWT} < 150,000$$

$$\text{Speed} = 15 + (\text{DWT} - 150,000) \cdot 0.000005; \text{ if DWT} > 150,000$$

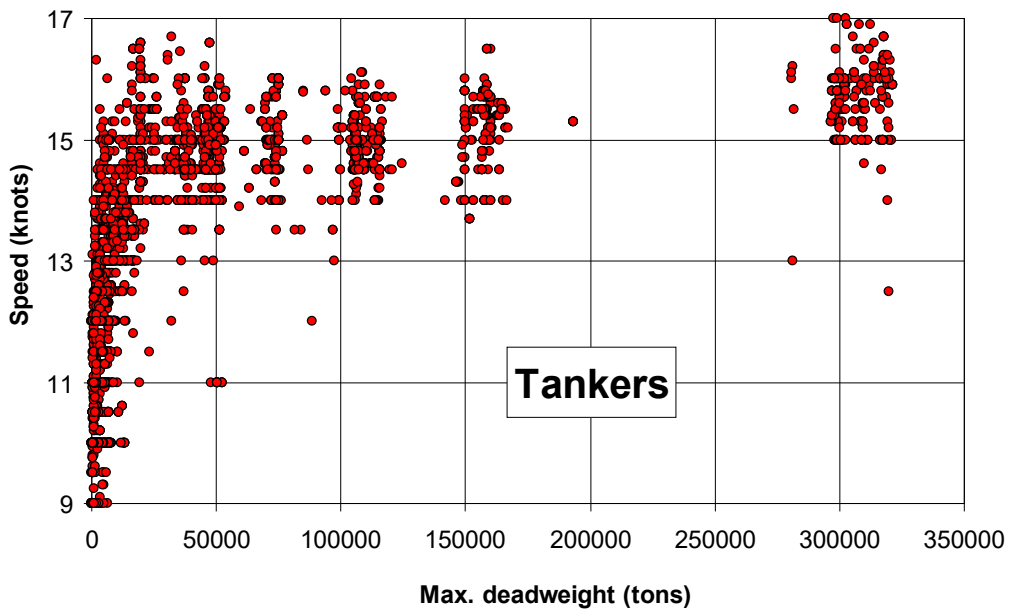

Figure 41 Maximum service speed for tankers function of maximum deadweight

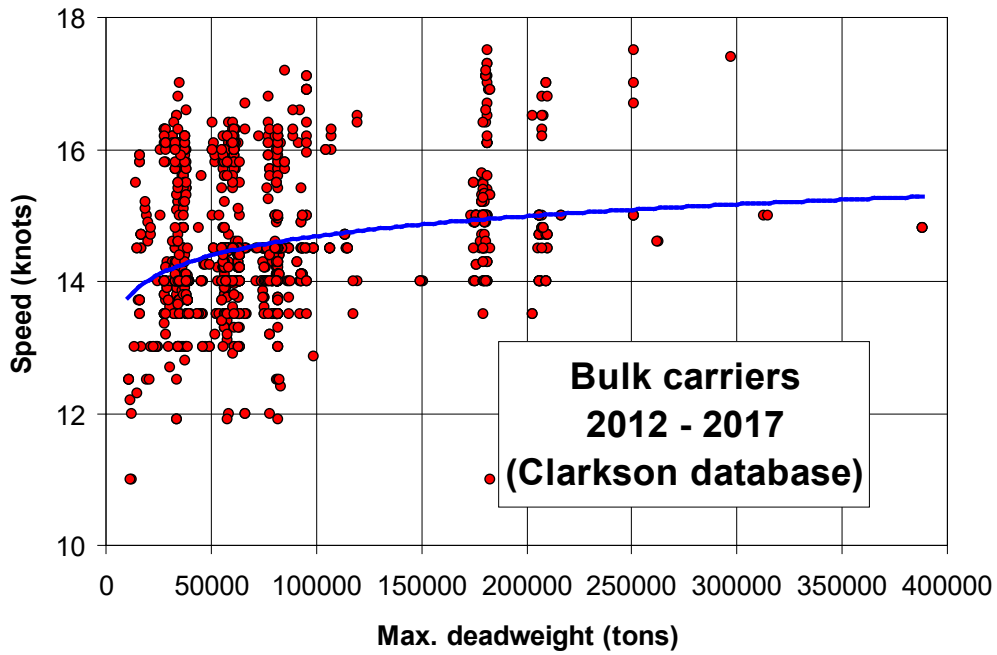

Figure 42 Maximum service speed for bulk carriers as function of maximum deadweight

The volume of bunker fuel tanks is shown in Figure 43 and can be expressed as follows:

$$\text{Volume of oil tanks} = 0.582 \times (\text{Max. deadweight})^{0.7469}$$

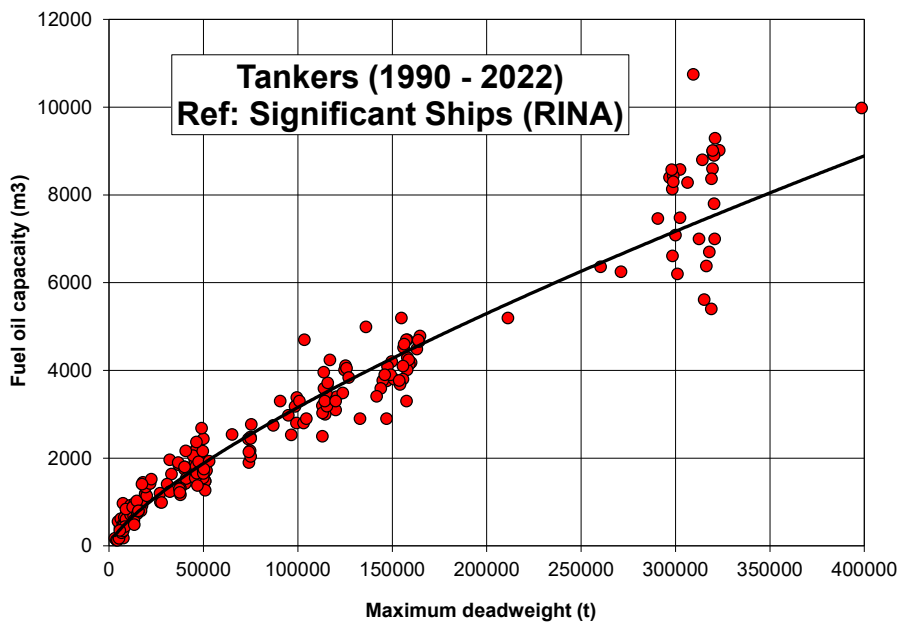

Figure 43 Bunker tank volume as function of maximum deadweight for tankers

### Ro-Ro cargo ferries

Below the data points for Ro-Ro cargo ferries are illustrated in various graphs. The data points are part of the source material for the data sheets.

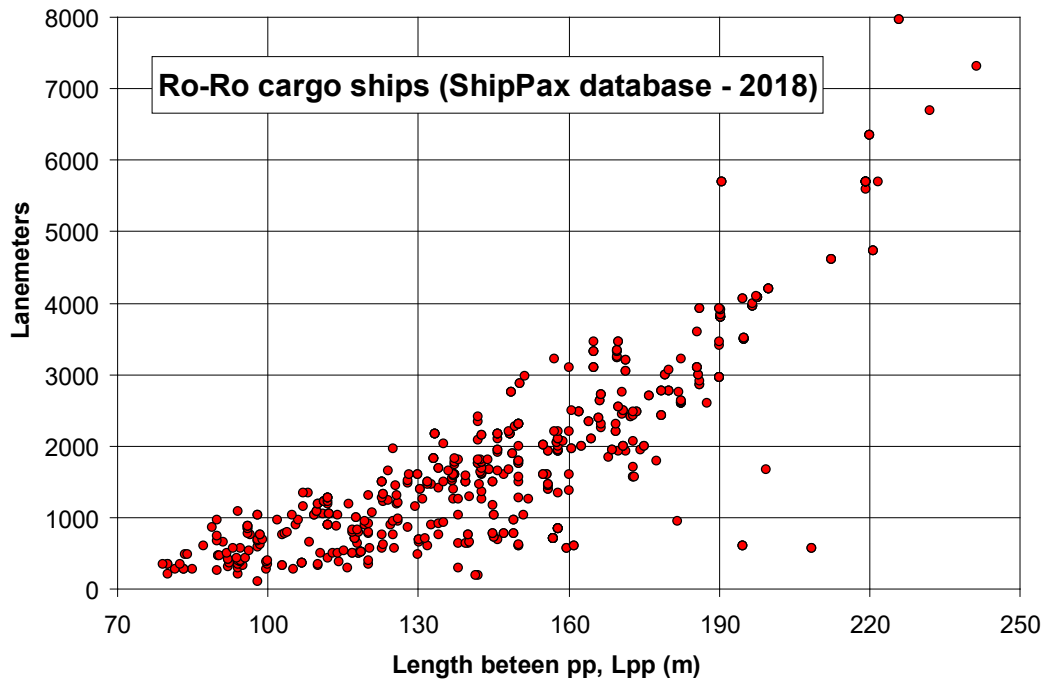

Figure 44 Lane meters for Ro-Ro cargo ships as function of length between pp, Lpp

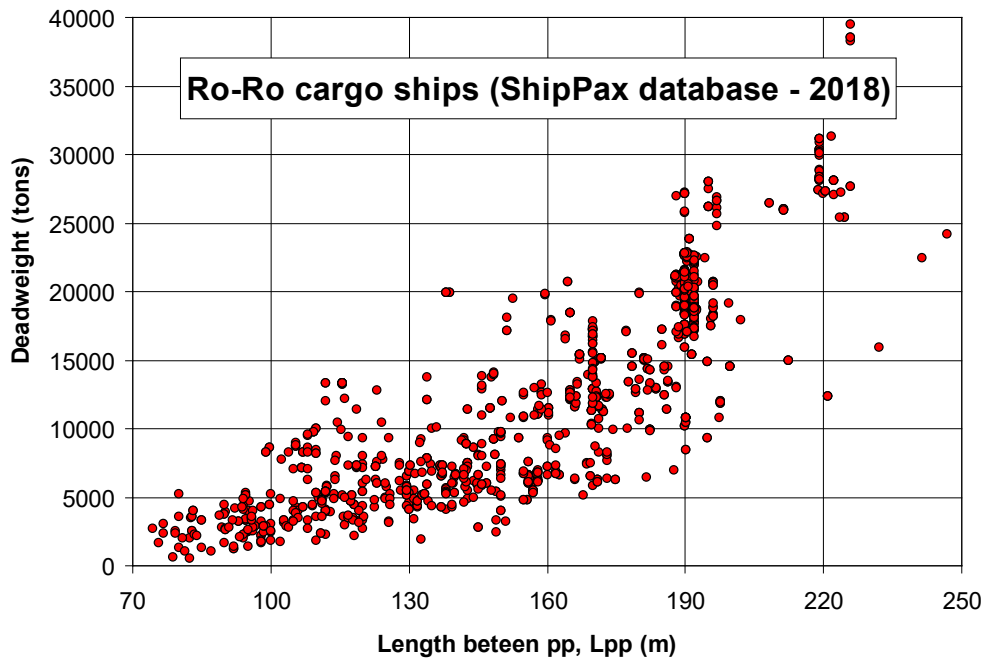

Figure 45 Deadweight for Ro-Ro cargo ships as function of length between pp, Lpp

The weight of cargo, payload, varies and the payload in pct. of maximum deadweight for Ro-Ro cargo and Ro-Ro passenger ships are shown in Figure 46. In these calculations it is assumed that the payload is 70 % and 65 % of the deadweight for Ro-Ro cargo and Ro-Ro passenger ships respectively.

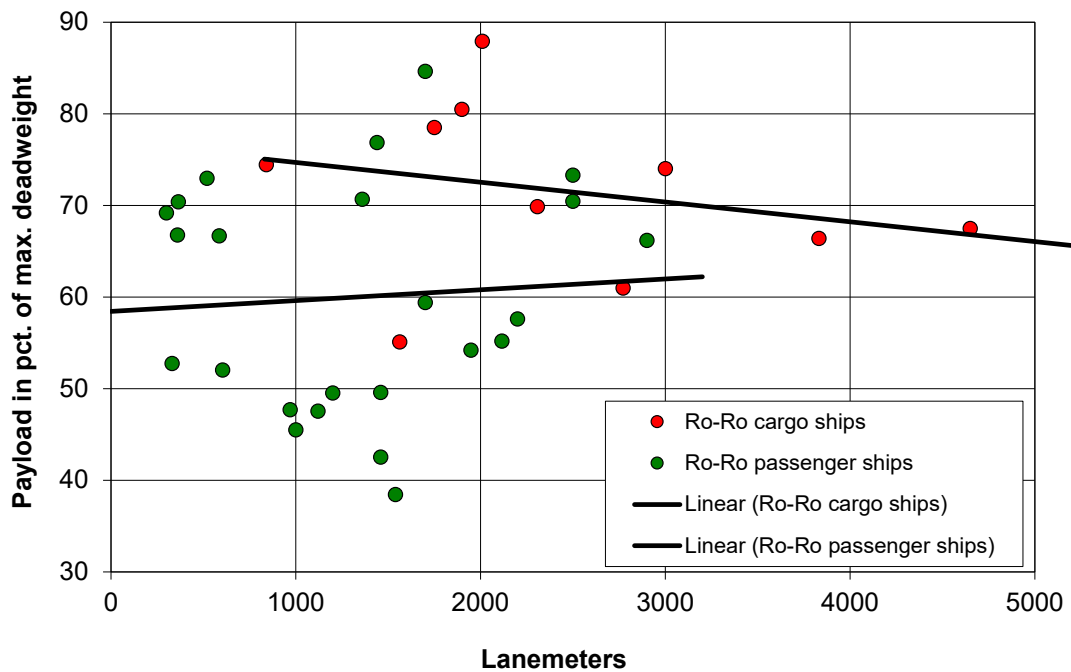

Figure 46 Payload for Ro-Ro ships as function of length of cargo lanes

The volume of bunker fuels tanks is shown in Figure 47 and can be expressed as follows:

$$\text{Volume of oil tanks} = 0.0656 \times L_{pp}^{1.933}$$

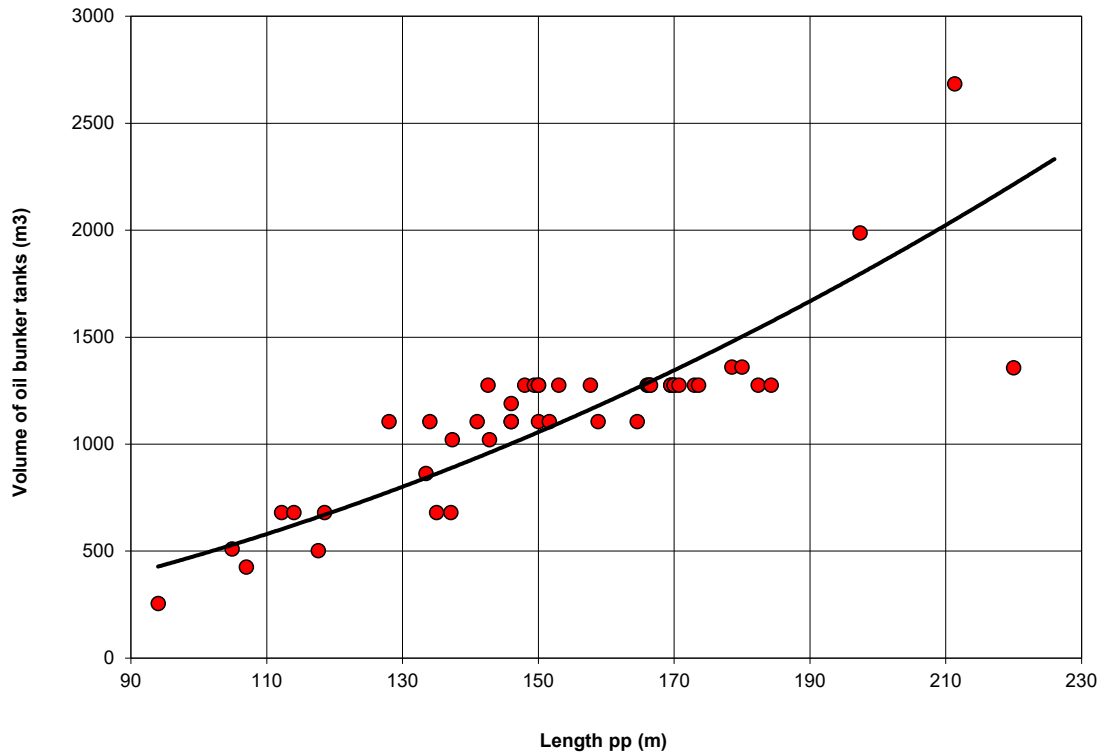

Figure 47 Bunker volume for Ro-Ro ships as function of length between pp

### Ro-Ro passenger ferries

Below the data points for Ro-Ro passenger ferries are illustrated in various graphs. The data points are part of the source material for the data sheets.

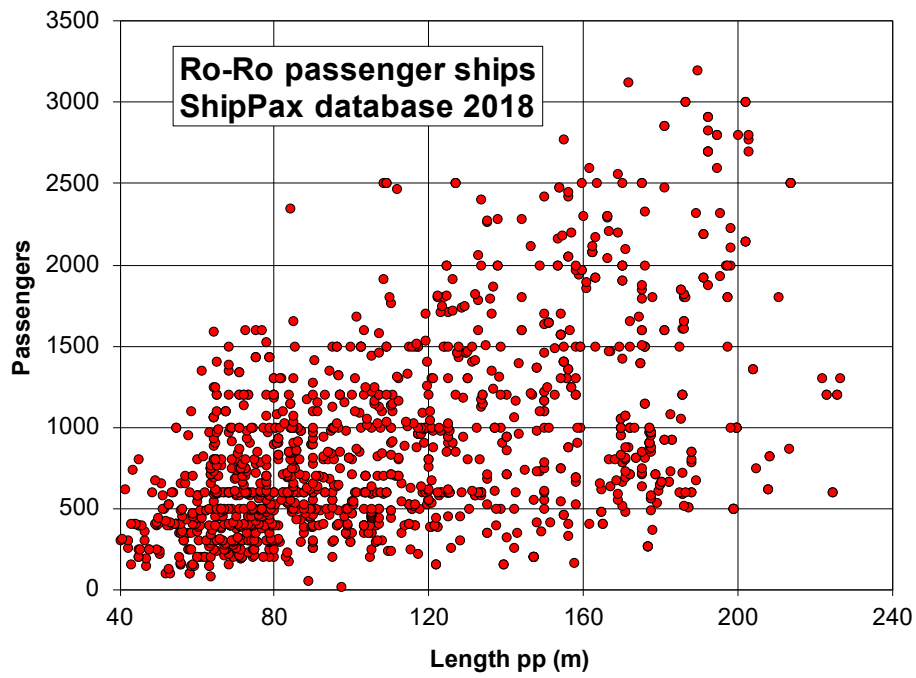

Figure 48 The length between pp, Lpp, as function of the passenger capacity

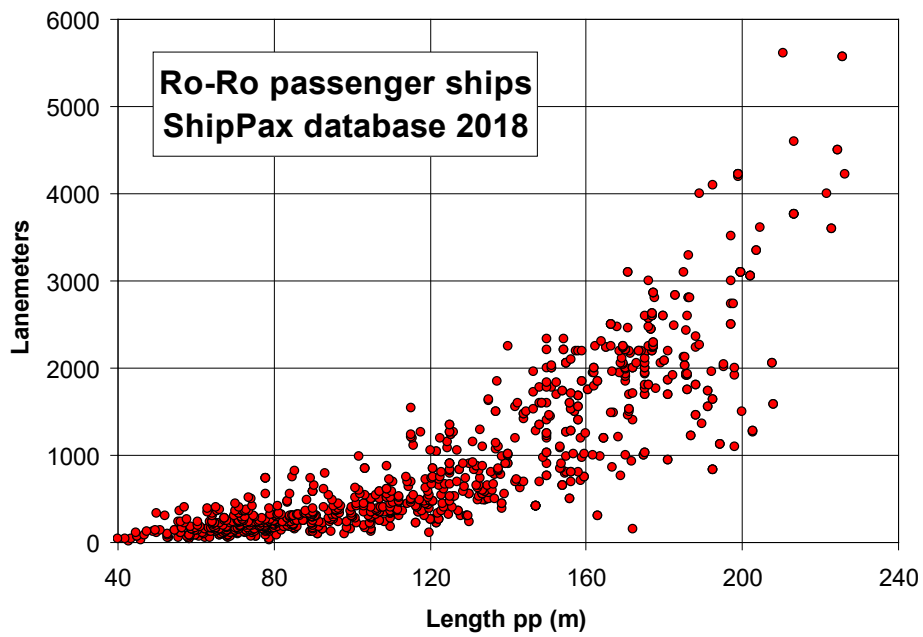
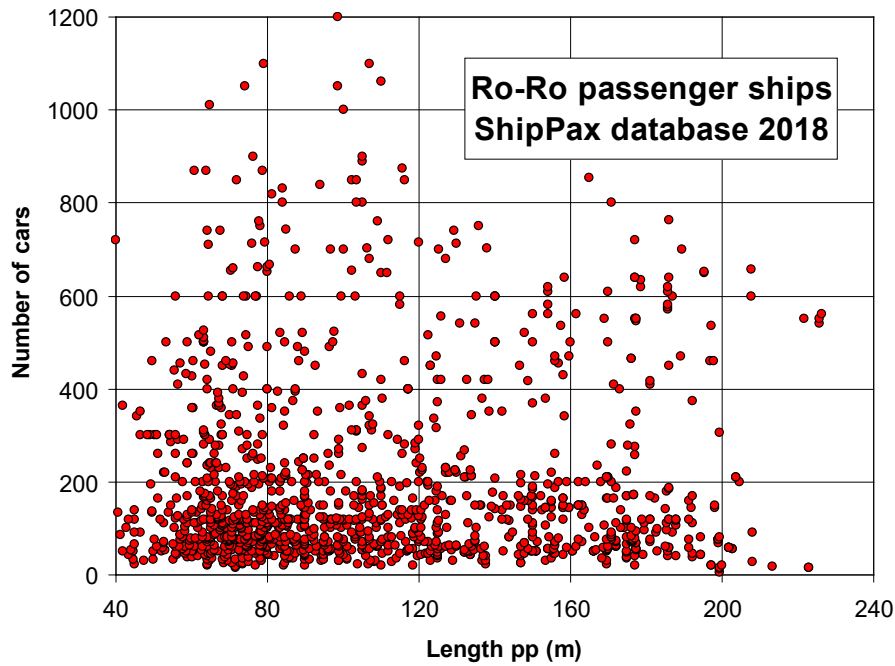

Figure 49 Lane meters as function of length between pp, Lpp



**Figure 50 The number of cars as function of length between pp, Lpp**

Speeds in service vary from approximately 12 knots on the smallest ferries, up to approx. 30 knots according to the ShipPax data (Figure 51), however with a large scatter, which make it quite difficult to establish a well proven length speed relationship. Due to the large scatter the speed data from ShipPax have been supplemented with speed data for 118 ferries from HOK Marineconsult's own database, selected carefully as representative for Ro-Ro passenger ships. In Figure 51 is shown a mean line found by regression analysis of the speed data, giving following linear relationship between maximum service speed and length between pp:

$$\text{Service speed in knots} = 0.085 \text{ Lpp} + 9$$

Service speed is normally adapted to suit an adequate timetable for the actual ferry route.

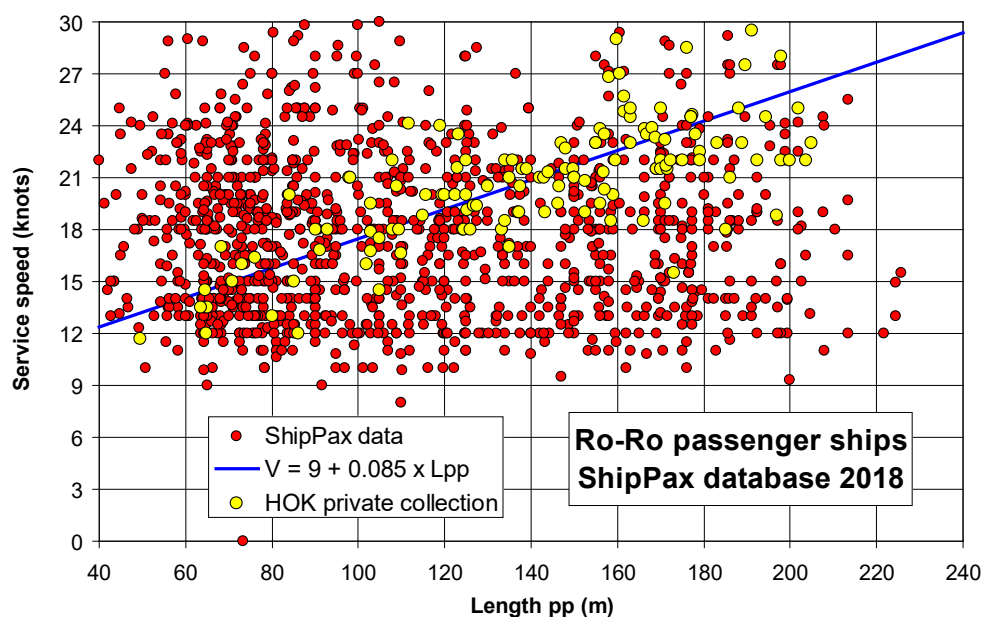

Figure 51 The service speed as function of length between pp, Lpp

### Fast ferries

Below the data points for fast ferries are illustrated in various graphs. The data points are part of the source material for the data sheets.

In Table 5 data for 16 fast catamaran ferries are shown of which five ferries have operated on the Rønne-Ystad route, while six other ferries have operated on the route between Odden and Aarhus since 1996. The majority of the ferries have been built at the two shipyards AUSTAL in Henderson in Australia and at INCAT in Hobart on Tasmania.

Table 5 Technical data for fast car carrying catamarans

	Lwl	Breadth total	Hull breadth	Draught	Light ship	Dead weight	Lightship/Lwl/Btotal	Displacement	Passenger capacity	Car capacity	Main engine power	Service engine loading	Speed
Ship	m	m	m	m	t	t	t/m <sup>2</sup>	t	-	-	MW	%	Knots
Red Jet 7	38	11	2.5	1.3	101.5	31.6	0.25	133.1	277	0	4	85	38
Halunder Jet	53	14	4.1	2	310	90	0.42	400	680	-	9	85	33
Incat 91 m wave piercer (Max Mols)	86	26	4.5	3.7	900	450	0.40	1,350	900	220	28	90	42
Francisco	93	27	5.2	3	1,063	450	0.42	1,513	955	150	44	85	50
A.P.T. James	94	26	7	3	1,000	595	0.41	1,595	926	250	29	90	37.5
Saint John Paul II	105	28	5.3	4.44	1,490	1,000	0.50	2,490	900	330	36	85	37.5
Express 4	106	31	5.8	3.9	1,500	1,000	0.46	2,500	1,006	425	36	75	37



	Lwl	Breadth total	Hull breadth	Draught	Light ship	Dead weight	Lightship/Lwl/Btotal	Displacement	Passenger capacity	Car capacity	Main engine power	Service engine loading	Speed
<b>Express 5</b>	111	31	6	3.3	1,930	1,000	0.57	2,930	1,600	451	39	80	40
<b>Incat 112 m wave piercer (Kat Exspress 1 &amp; 2)</b>	106	31	-	3.9	1,550	1,000	0.48	2,550	1,182	417	36	100	39
<b>Austal Auto Express 113 (Leonora Christina)</b>	101	26	-	4.85	-	1,000	-	-	1,487	357	36	90	38
<b>Seajet katamaran (Mie &amp; Mai Mols)</b>	63	23	-	3.36	-	250	-	-	450	120	24	90	40,8
<b>Austal Auto Express 69 (Jazan &amp; Farasan)</b>	62	18	-	3	-	258	-	-	651	74	12	90	32
<b>Austal Auto Express 113 (Huakai)</b>	92	24	-	3.65	-	800	-	-	866	258	33	90	35
<b>Villum Clausen</b>	84	25	-	4	-	450	-	-	1,055	286	24	90	38
<b>Austal Auto Express 88 (Riyadh &amp; Cairo)</b>	77	24	-	4.3	-	555	-	-	1,219	175	29	90	34
<b>Austal Auto Express 107 (Jean de la Valette)</b>	92	24	-	4.9	-	850	-	-	920	156	36	85	39

The fast ferries capacity ranges from approx. 70 to 450 cars, within a length 60 m to 115 m (Figure 52). The passenger capacity is 450 to 1,600 (Figure 53) with a deadweight range of 250 tonnes to 1,000 tonnes (Figure 54).

Using the statistical material shown in Table 5 a generic ship design model for technical calculations and energy calculations of modern fast car carrying catamarans has been developed for this catalogue. The associated power predictions have been carried out using empirical methods (Breslin, 1994; Van Oosanen, 1980; Insel, 1992). The calculated displacements for different sizes using the generic method are shown in Figure 55 compared with the real displacements listed in Table 5. The calculated main engine power corresponding to 40 knots (average speed for the actual ferry segment) is shown in Figure 56 for different ferry sizes. Also, in this figure the real engine power values are shown, and a relatively good agreement is observed between these values and the values calculated by the design model, taking into account the statistical related uncertainties.

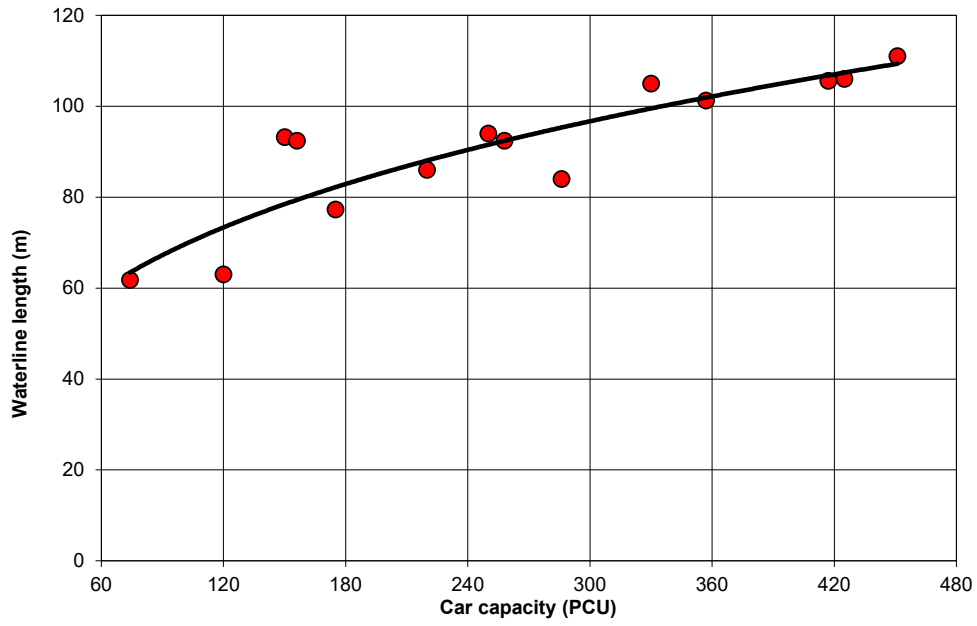

Figure 52 Waterline length, Lwl, as function of the car capacity

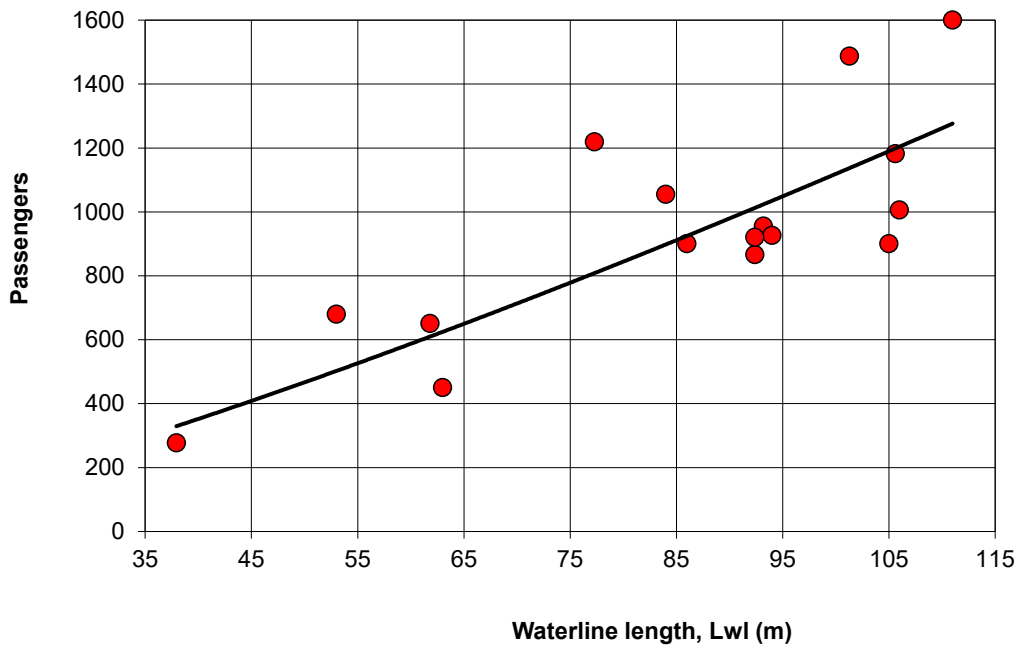

Figure 53 Passenger capacity as function of the waterline length, Lwl

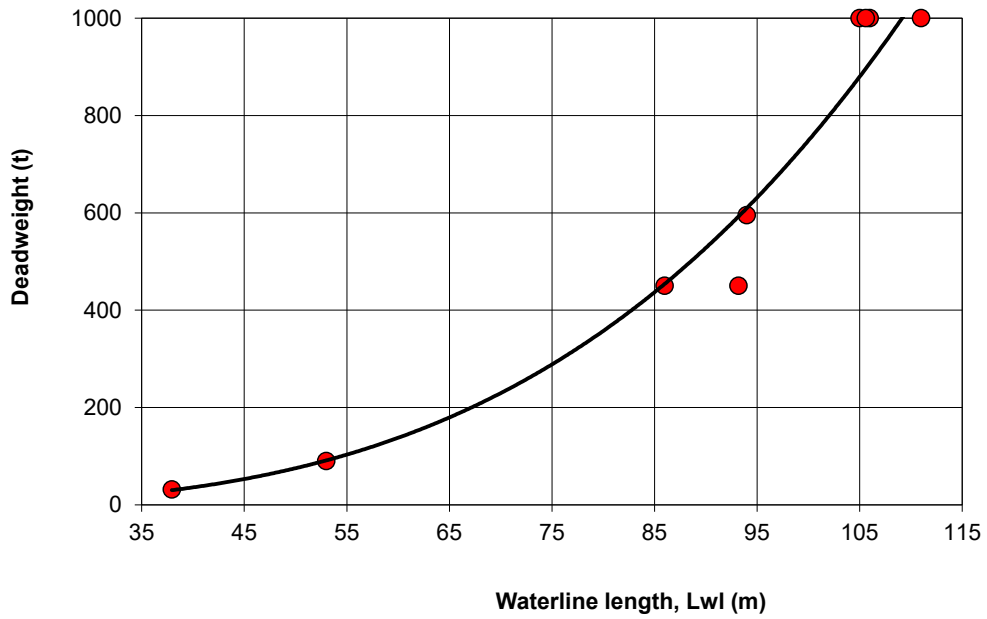

Figure 54 Deadweight as function of the waterline length, Lwl

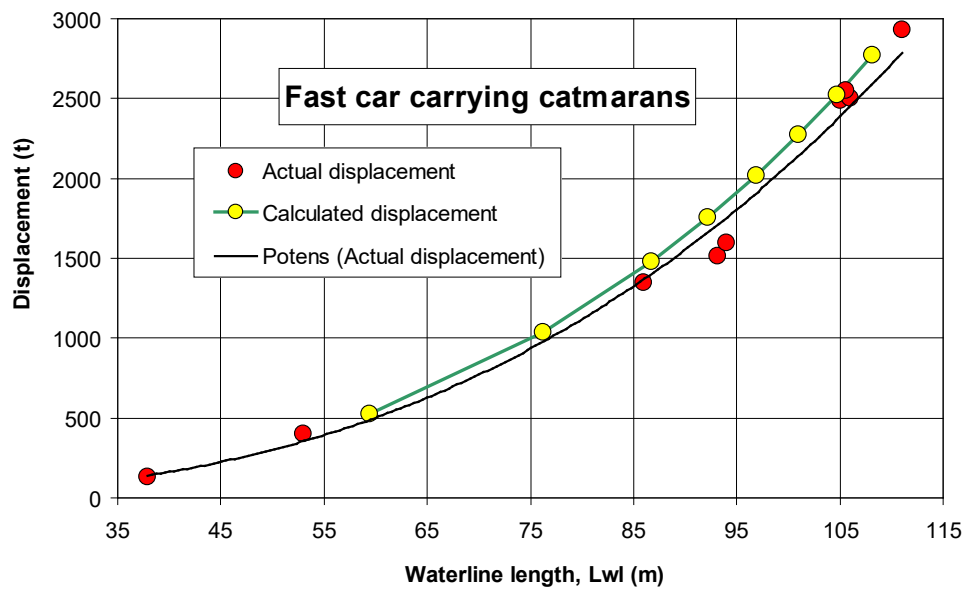

Figure 55 Displacement as function of the waterline length, Lwl

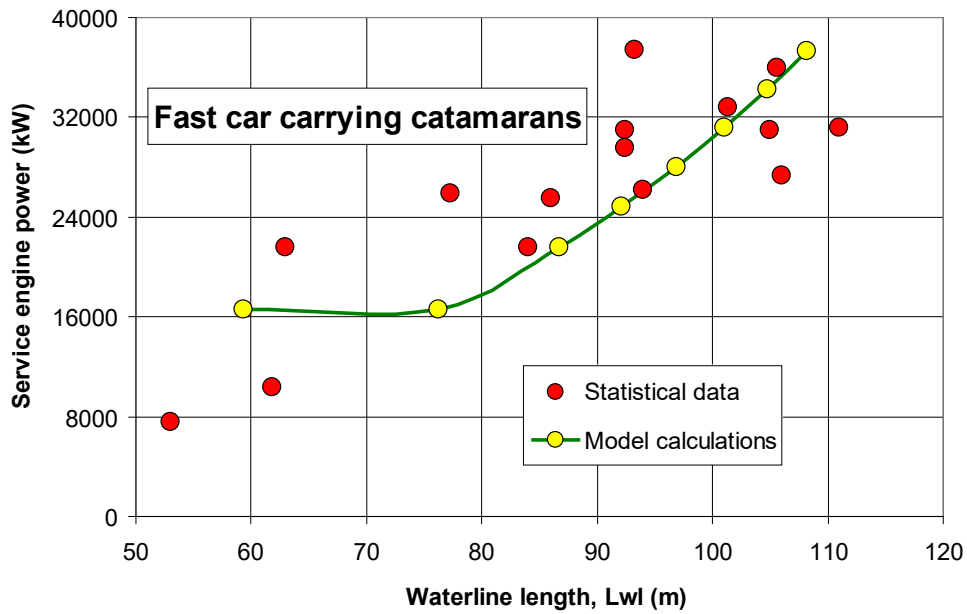

Figure 56 Main engine power as function of the waterline length, Lwl

A very interesting performance indicator related to car ferries is the oil consumption per car per nautical mile, which is shown in Figure 57 for the actual car carrying catamaran ferries (in Table 5) compared with the calculated values for different ferry sizes. It is interesting to observe the drastic energy reduction related to the ferry size alone. The really large catamaran ferries, which are now introduced on the market, show much lower oil consumption compared to the first fast ferries of moderate size (120 cars) introduced in 1996.

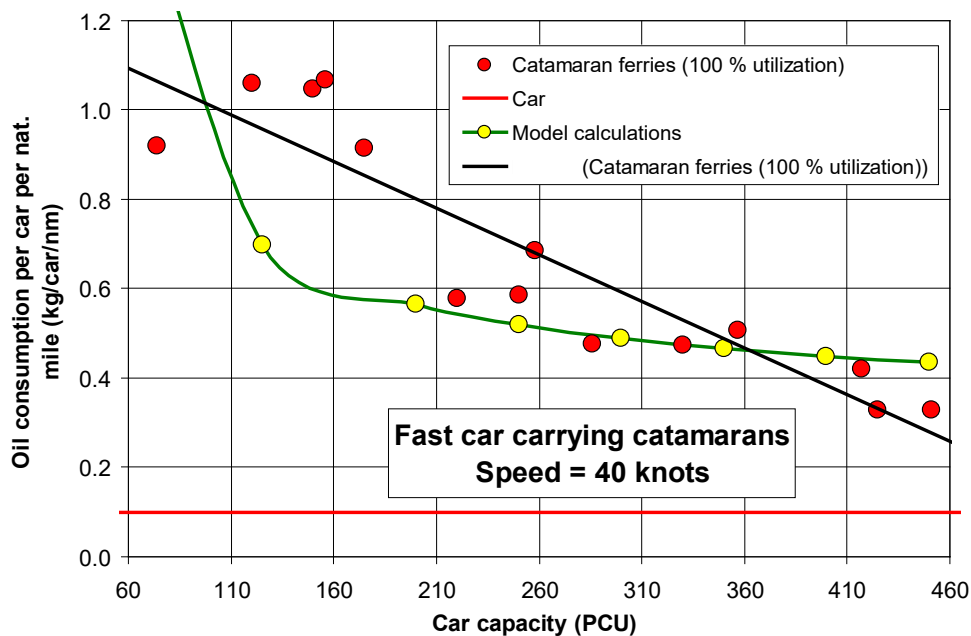

Figure 57 Oil consumption per car per nautical mile as function of car capacity

### Small ferries

Below the data points for small ferries are illustrated in various graphs. The data points are part of the source material for the data sheets.

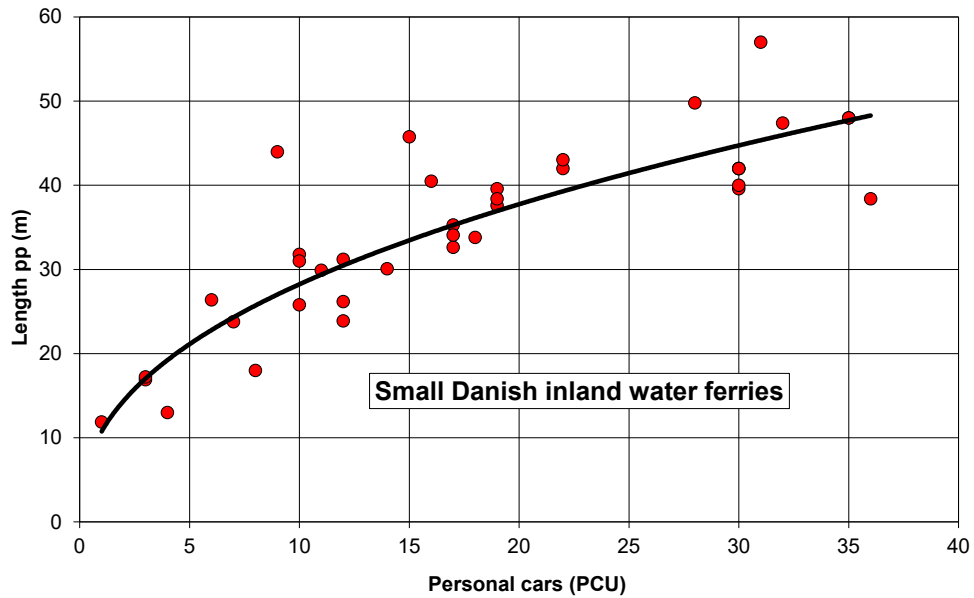

Figure 58 Length between pp as function of the personal car capacity

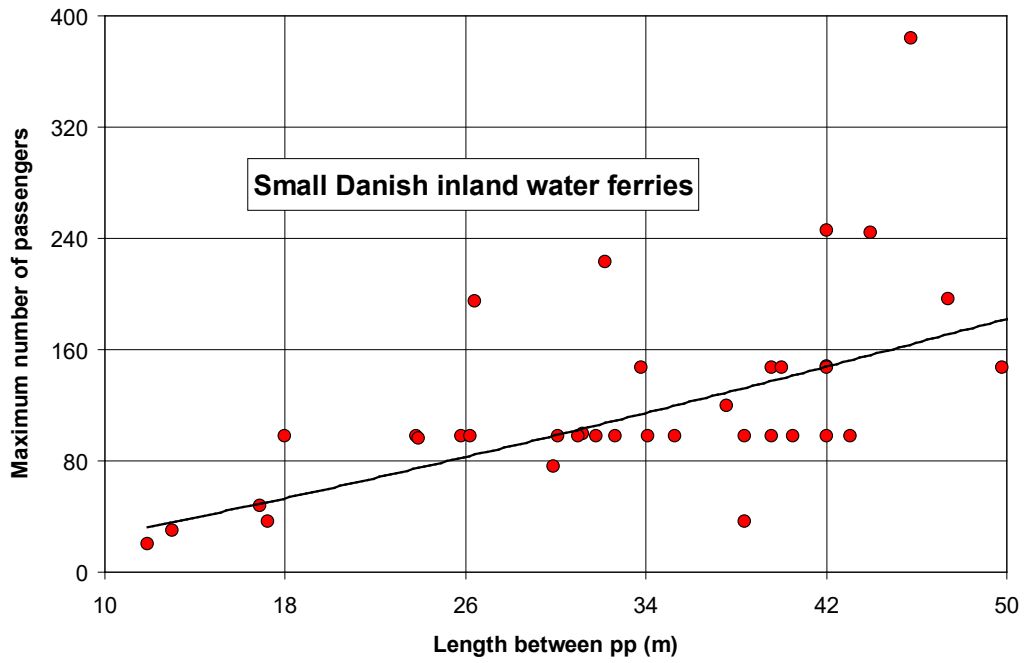

Figure 59 Maximum number of passengers as function of the length between pp

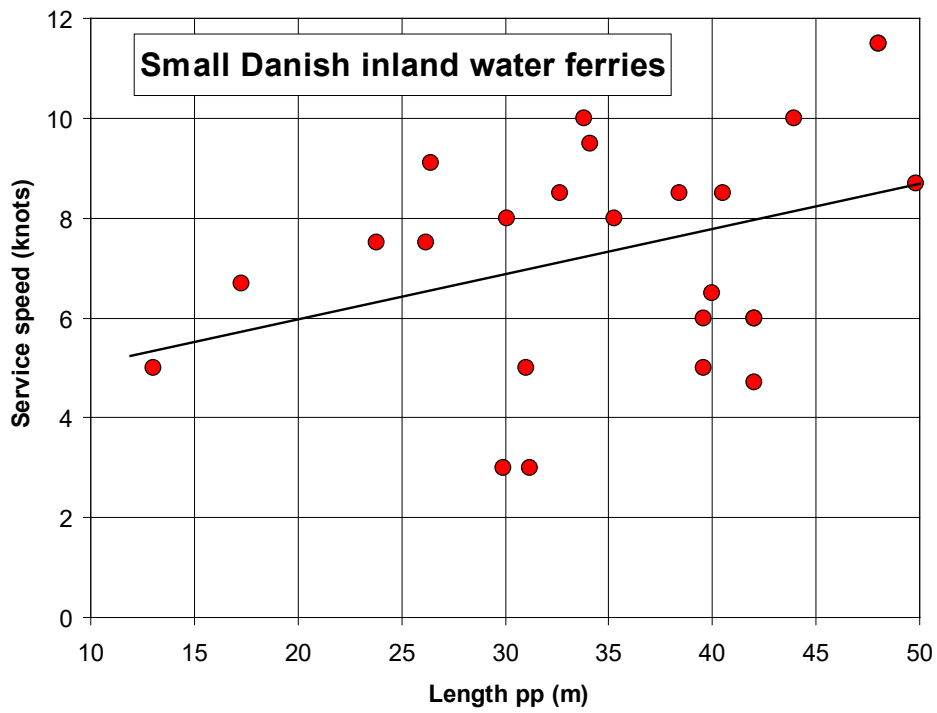

Figure 60 Service speed for the different ferry routes

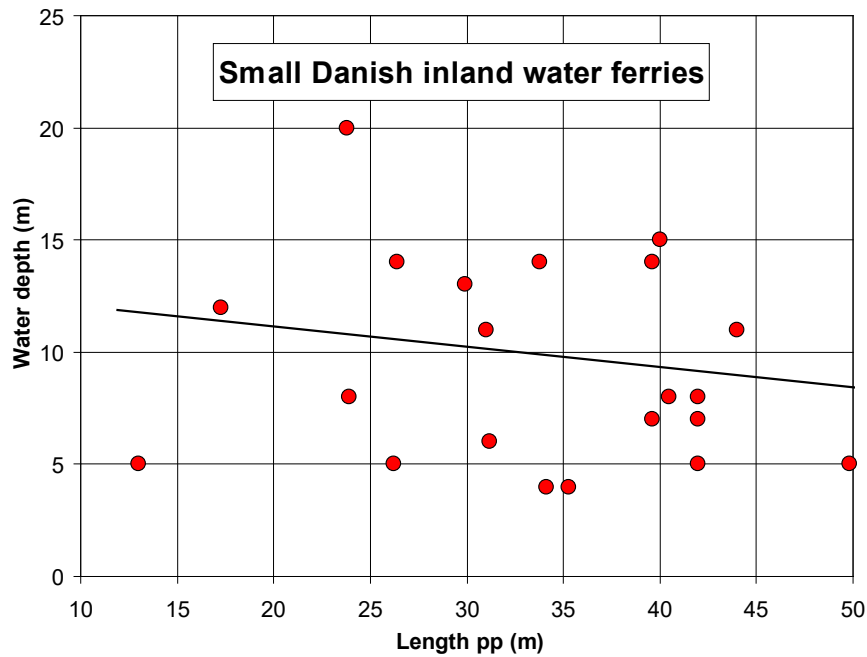

Figure 61 Water depth for the different ferry routes

For the actual ferries used for the development of the generic ship design and power prediction calculation model, observed data for the oil consumption during a year have been analysed to find the average total oil consumption per nautical mile as shown in Figure 62. Oil consumption data calculated with the model are also shown in Figure 62, which shows a fine correlation between the observed data and the calculated data having in mind, that the observed data also includes use of oil in periods, when the ferries are idling during their stay in the ports, which is not included in the generic calculation model.

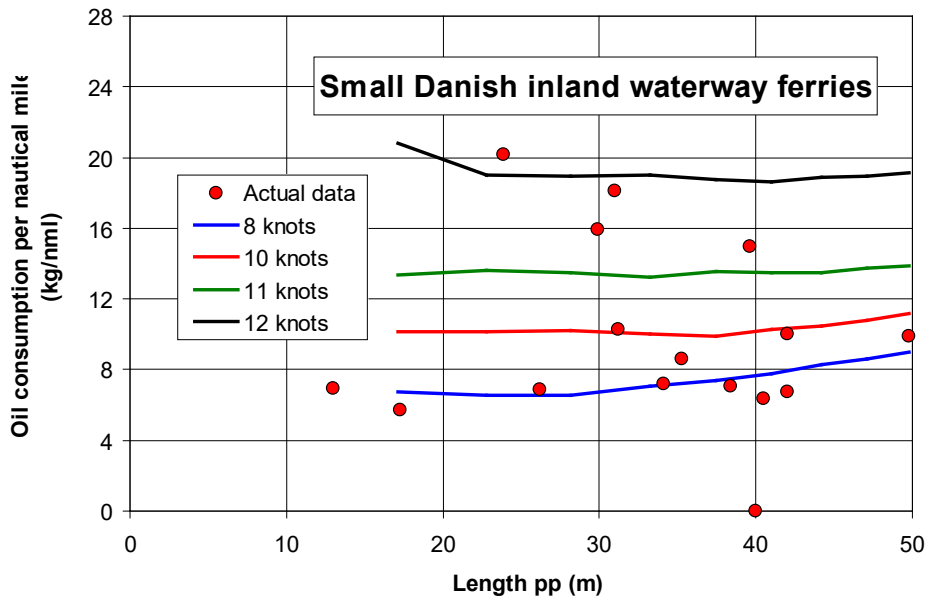

Figure 62 Oil consumption data as function of the length between pp, Lpp

### 7.3. Energy and fuel related parameters

#### Energy density

The energy density of a fuel is an important factor for its applicability. The higher the density, the less storage space is required for normal operation of the vessel.

Figure 63 shows the energy densities, expressed in MJ per litre ( $\text{dm}^3$ ) for the fuel itself as well as the density including packaging (size of the storage tanks including secondary barriers and cofferdams). Diesel, MGO and HFO, as reference fuels, have a relatively high energy density compared to the alternative fuel types. Methanol has a significantly lower density than diesel, but higher than the other fuels in the comparison, especially when taking packaging into account.



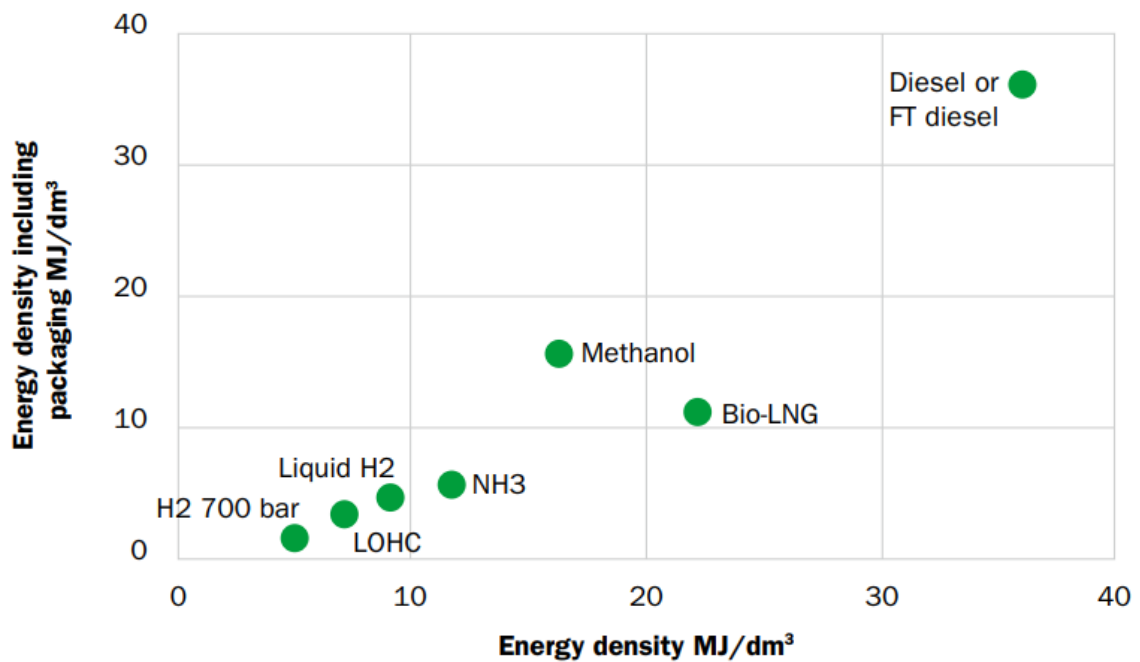

Figure 63 Energy density of different fuels (Harmsen, 2021)

As illustrated in Table 6, the volume of methanol is 2.3 times higher than for diesel oil and for ammonia 2.9 times higher than for diesel oil (and even larger when the additional volume of the ammonia tank arrangement is taken into account, see Figure 63).

Table 6 Properties of marine fuel types

Energy carrier	Density	Energy content*	Energy content	Weight per 1,000 energy	Volume per 1,000 energy
	kg/litre	MJ/kg	MJ/litre	kg	litre
Diesel oil (MGO)	0.85	42.7	36.3	84	99
HFO	0.95	40.2	38.2	90	94
Methanol	0.79	19.9	15.7	181	230
Ammonia, liquefied	0.68	18.6	12.7	194	284
Ammonia, compressed	0.63	18.6	11.7	194	309

Energy carrier	Density	Energy content*	Energy content	Weight per 1,000 kWh energy	Volume per 1,000 kWh energy
	kg/litre	MJ/kg	MJ/litre	kg	litre
<b>Hydrogen, liquefied</b>	0.07	120.0	8.5	30	424
<b>Hydrogen, compressed</b>	0.02	120.0	2.5	30	1,463
<b>Batteries</b>		0.6		6,000	

(\*) Lower calorific value

As mentioned, methanol and ammonia require larger fuel tanks, which means that a larger part of the deadweight of the ship must be dedicated for fuel (roughly 3 times more compared to diesel fuel). It is of course a disadvantage to exclude that part of the deadweight, as it means less payload (roughly 5 – 10 % for container ships and tankers and bulk carriers). However, by a careful project planning this problem can be solved during the design phase, and less bunker tank reserve margins in the future might be a result of this challenge.

The volume and weight of hydrogen and batteries are very high, making those unfeasible for larger ships.

### Specific fuel oil consumption (SFOC) and emission types

In order to calculate the energy demand and emissions for the different ship types it is necessary to know the specific energy demand requirements, i.e. the specific fuel oil consumption (SFOC) and the emissions from the engines, which are installed for propulsion and the generation of electrical power on the ships.

The oil consumption corresponds to fuels with the specified calorific value of 42.7 MJ/kg corresponding to marine diesel oil or gas oil (MDO and MGO). If heavy fuel oil (HFO) with a calorific value of 40.5 MJ/kg is used, the SFOC values in Table 7 are 5.7 % higher (42.7/40.5). For a de-rated engine, the SFOC is approximately 4 % lower than the values given in Table 7, according to information from different engine manufacturers.

**Table 7 Approximation of typical SFOC values for different diesel engine types (at 42.7 MJ/kg oil)**

	Gram per kWh
<b>Low speed engines:</b>	155 - 175
<b>Medium speed engines:</b>	175 - 200
<b>High speed engines:</b>	195 - 225

## 7.4. Environment and climate

The environmental and climate footprint of ships come from the building phase, scrapping and use during the entire lifetime of the ship. The scope of this report is restricted to the daily operation of the ships. Local emissions of CO<sub>2</sub>, CH<sub>4</sub>, N<sub>2</sub>O, NO<sub>x</sub>, SO<sub>2</sub>, HC, CO and particulates resulting from the operation of the ship are included. Black carbon (BC) is a part of particulates (ranging from approximately 25 % to 85 % of the total particulate emission depending on the engine type) and is not reported separately. Emissions rates are modelled into SHIP-DESMO except for N<sub>2</sub>O, which is calculated separately based on Table 9.

### Fuel specific emission rates

#### Greenhouse gas emissions

The tank-to-wake emission of CO<sub>2</sub> is proportional with the fuel oil consumption by following fuel specific emission rates:

**Table 8 CO<sub>2</sub>-emission rates for different fuels based on (IMO, 2022)**

Fuel	CO <sub>2</sub> -emission factor, kg/kg fuel
Heavy Fuel Oil (HFO)	3.114
Diesel Oil/Gas Oil (DO/GO)	3.206
Methanol	1.375
Ammonia	0

Emission factors used for CH<sub>4</sub> and N<sub>2</sub>O are displayed in Table 9.

**Table 9 N<sub>2</sub>O and CH<sub>4</sub> emission factors based on (European Commission, 2021) and Aarhus University**

Fuel/engine type	N <sub>2</sub> O (g/kWh)	N <sub>2</sub> O (g/kg fuel)	CH <sub>4</sub> (g/kWh)	CH <sub>4</sub> (g/kg fuel)
Diesel oil (2 stroke)	0.031	0.18	0.01	0.059
Diesel oil (4 stroke)	0.034	0.18	0.01	0.053
Methanol (2 stroke)	0.064	0.18	0.01	0.028
Methanol (4 stroke)	0.071	0.18	0.01	0.026

**Air pollution**

SO<sub>2</sub> is proportional with the fuel oil consumption and the content of sulphur in the oil by the following theoretical fuel specific emission rate equation, where S is the percentage mass sulphur content in the fuel (also see Figure 64).

$$21 \times S = \text{grams SO}_2 \text{ per kWh}$$

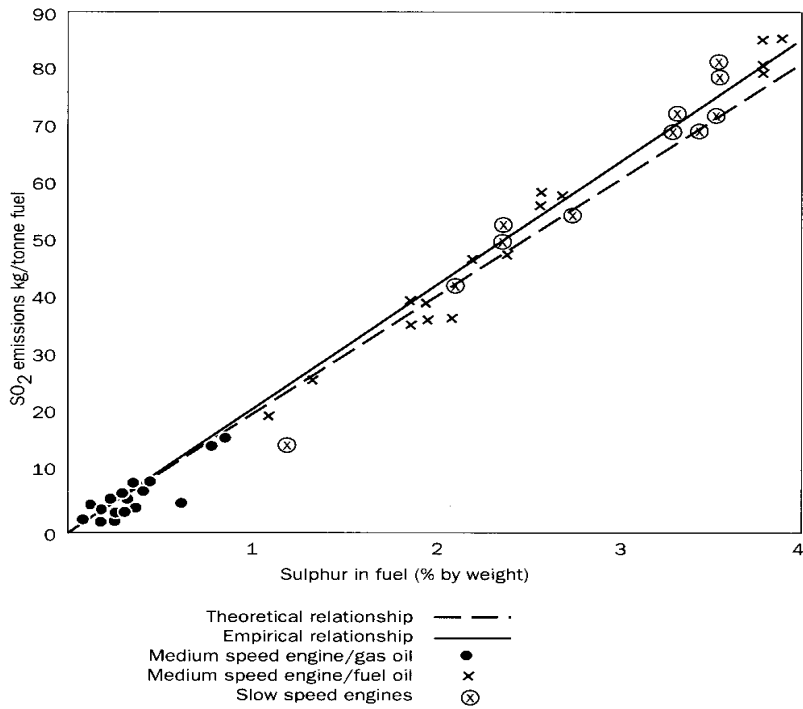

**Figure 64 Relationship between fuel sulphur content and SO<sub>2</sub> emissions for marine diesel engines (Lloyds Register of Shipping, 1995)**

HC and CO emission factors are partly based on the measurements done by (Lloyds Register of Shipping, 1995) and the results from MAN Energy Solutions.

There can be quite large variations in the emission factors depending on the engine loading (steady state/transient). For marine diesel engines the variation in steady-state mode is as follows, according to (Lloyds Register of Shipping, 1995):

**Table 10 Variation of emissions in steady-state mode**

	g/kWh
<b>NO<sub>x</sub>:</b>	8-20
<b>HC:</b>	0.2-1.0
<b>CO:</b>	0.4-4.0
<b>Particulates:</b>	0.2-2.0

Figure 65 shows the empirically approximated relationship between the sulphur content of the fuel and particulate emissions, which has been used to determine particulate emissions. Based on these curves the following equation has been derived for the particulate emission factor for diesel engines:

$$\text{Particulate emission factor in g/kWh} = 0.26 + 0.081 \cdot S + 0.103 \cdot S^2$$

Where S is the sulphur content in %.

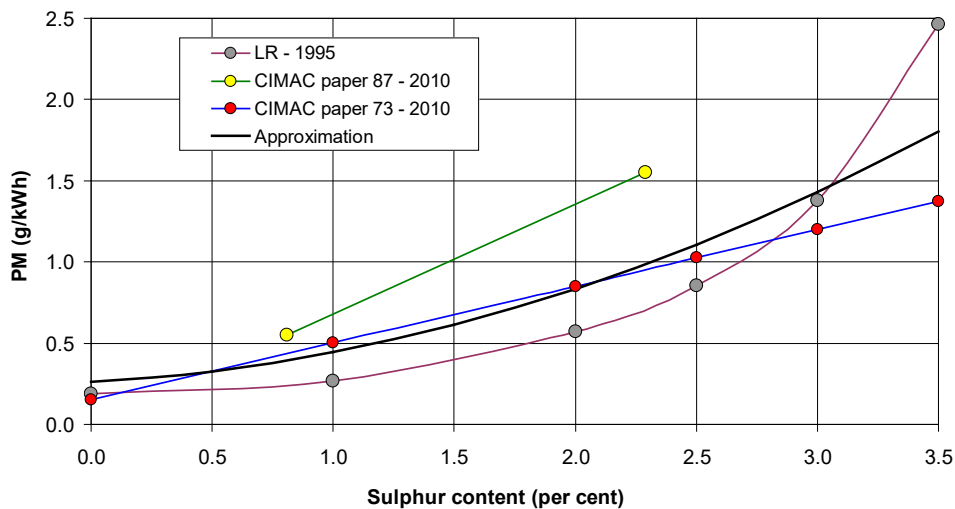

**Figure 65 Relationship between fuel sulphur content and emissions of particulates, PM (Lloyds Register 1995 and CIMAC 2010)**

## 7.5. Financial data

### Typical ship lifetime

The typical lifetime of a ship is 30 years. Ferries can be older depending on the maintenance, whereas some merchant ships can have a lower lifetime.

### Typical battery lifetime

The typical lifespan of a battery is assumed to be 10 years, but ultimately depends on how often and how much it is charged. The current expectations for battery lifetime means that they must be replaced during a ship's lifetime. However, in the case of new battery technology able to extend the expected lifetime, this figure may change. As of now, LFP (Lithium Iron Phosphate) batteries are being introduced in the maritime sector. LFP batteries have been introduced in other electric transport modes, and have certain advantages over NMC batteries and have been known to extend the battery lifetime significantly. There will be several decisive factors when determining a well suited battery, including battery life time but also other parameters such as costs, efficiency, charging capacities, energy density and safety. Therefore, battery lifetime will only be part of identifying an optimal solution for battery electric ships.

### Upfront ship costs

The costs of propulsion systems must be seen in the context of the ship type as variations are large. It has not been possible to extract the costs of the propulsion system and CAPEX are reported for an entire vessel.

There is reliable data, which can be used to estimate CAPEX for conventional ICEs. As data for methanol and ammonia powered ships is not available, those estimates are based on insecure assumptions, where observable the prices for conventional diesel ships are adjusted. From press releases about Maersk's ordered methanol container ships (Maersk, 2022), an average mark-up of 10 % is added on top of the price for conventional ships. For ammonia a mark-up of 20 % is added (Global Maritime Forum, 2023). For both ammonia and methanol, prices are expected to decrease, as the technologies become more widespread and mature. Both production costs are expected to decrease as well as an increase in supply to meet demand.

For small battery electric ferries the costs are observable. For the larger Ro-Ro ferries, a mark up of 20 % is assumed compared to the prices for conventional ferries. The price difference is expected to decrease as the technology becomes more widespread and mature.

### CAPEX Container ships

Like for many of the technical properties of container ships, the price of container ships depends on the container capacity in TEU. Up to date data prices have been found in (HANSA, 2023b) and are shown in Figure 66, where a nearly linear relationship between the price and the TEU capacity is seen. This linearity has been assumed for the whole range of container ships up to the very large ships of more than 20,000 TEU, such that following formula for extrapolation has been found (Figure 66).

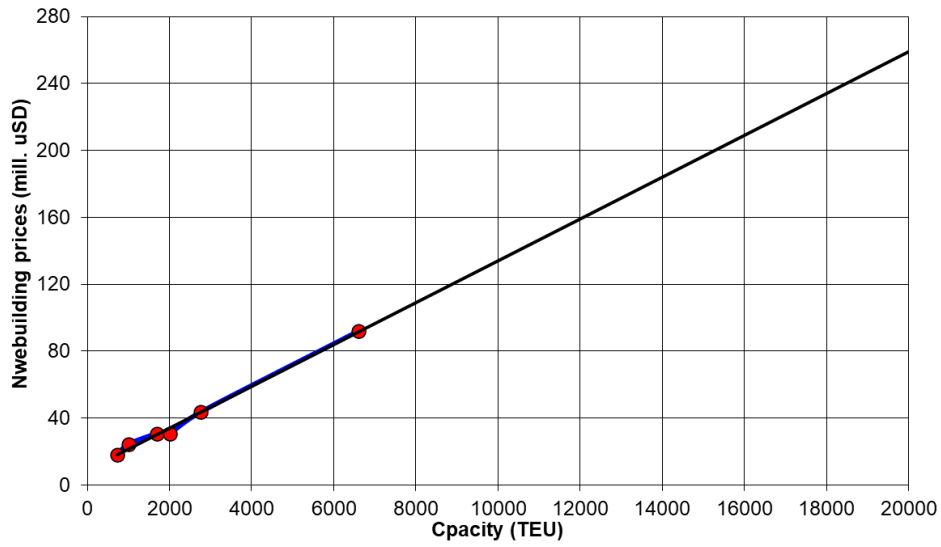

Figure 66 Extrapolated newbuilding prices for container ships (HANSA, 2023b)

### CAPEX Tankers

Like for many of the technical properties of tankers, the price of tankers depends on the maximum deadweight capacity in tonnes. The price data and formula for calculation of tanker price is shown in Figure 67.

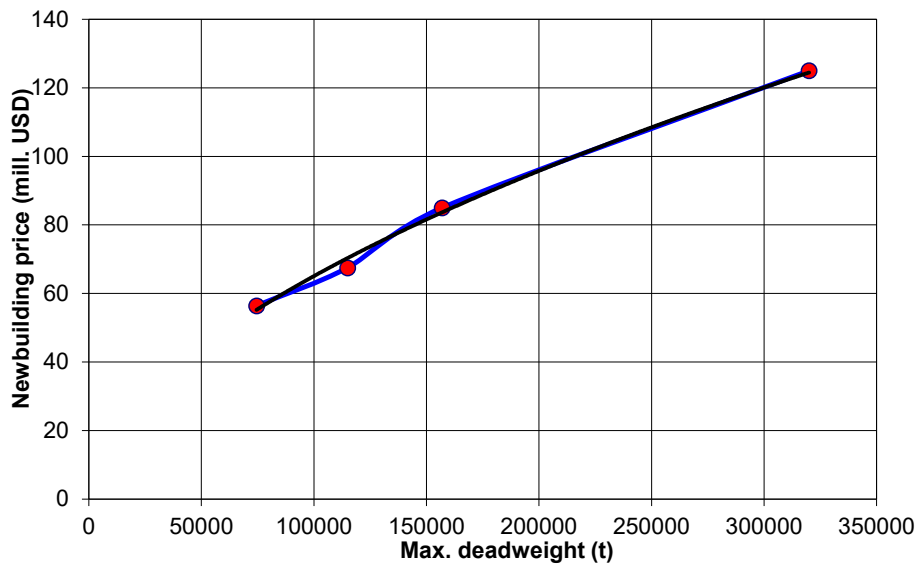

Figure 67 Newbuilding prices for tankers (HANSA, 2023b)

**CAPEX Bulk carriers**

Like for many of the technical properties of bulk carriers, the price of tankers depends on the maximum deadweight capacity in tonnes. The price data and formula for calculation of bulk carrier price is shown in Figure 68, where a nearly linear relationship between the price and the max. deadweight is seen. This linearity has been assumed for the whole range of bulk carriers up to the very large bulk carriers of more than 350,000 tonnes deadweight.

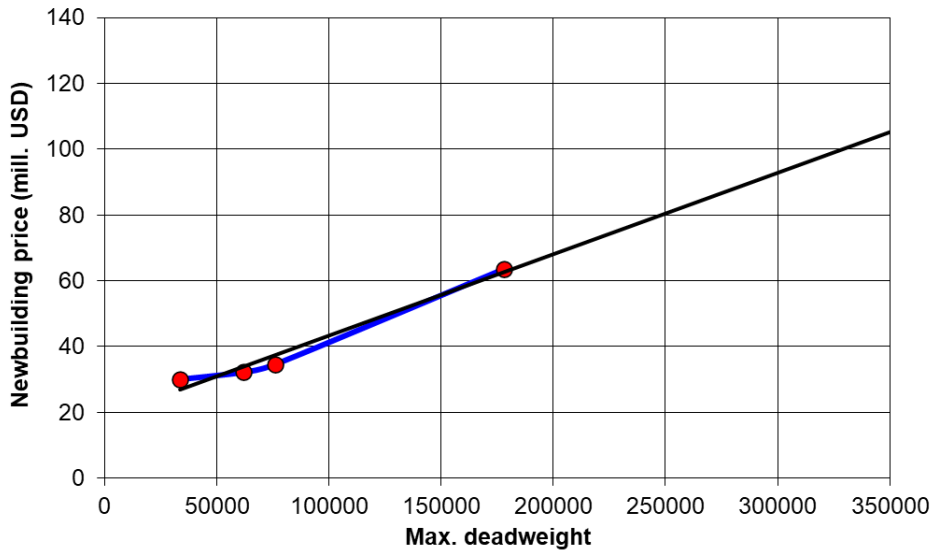

Figure 68 Newbuilding prices for bulk carriers (HANSA, 2023b)

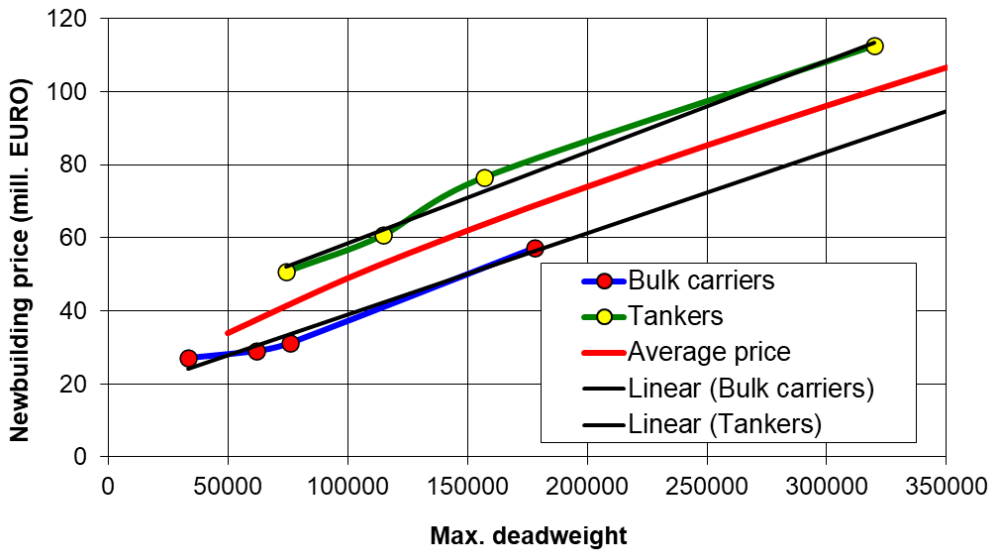

Figure 69 Newbuilding prices for tankers and bulk carriers (HANSA, 2023b)



As the common price for tankers and bulk carrier the average value of tankers and bulk carriers, shown in Figure 69, is used, i.e.:

$$\text{Newbuilding price in mill. USD} = [0.0954 \cdot \text{Max. deadweight}^{0.558} + 16.65 + 0.000223 \cdot \text{Max. deadweight}] / 2$$

### CAPEX Ro-Ro passenger ships and Ro-Ro cargo ships

Since individual car ferry designs vary considerably regarding number of car decks, number of passengers including passenger areas, speed and machinery etc. it is not surprising, that variations in prices are great as well. It is judged that the gross tonnage (which is a measure of the ships total volume) is most probably the best parameter to use for a rough price estimation. Especially during the last 5 – 10 years the variation of ferry designs has become very large, such that it will only be possible to establish a very rough method for calculation of newbuilding prices, taking into account that the price level is largely dependent on the building country and the development of building prices especially during the last 2 – 3 years.

Some recent price data corresponding to 2023 level have been obtained from the Swedish ShipPax database, combined with price data from 2018 – 2021 for some Danish ferries. The price level of these ferries has individually been corrected assuming a price increase of 25 % during the last 2 – 3 years based on discussions with shipyards and ship-owners.

Following the very general calculation formula of the newbuilding price of Ro-Ro passenger ships has been found corresponding to Figure 70:

$$\text{Price (mill. EURO)} = 0.35 \cdot \text{GT}^{0.557}$$

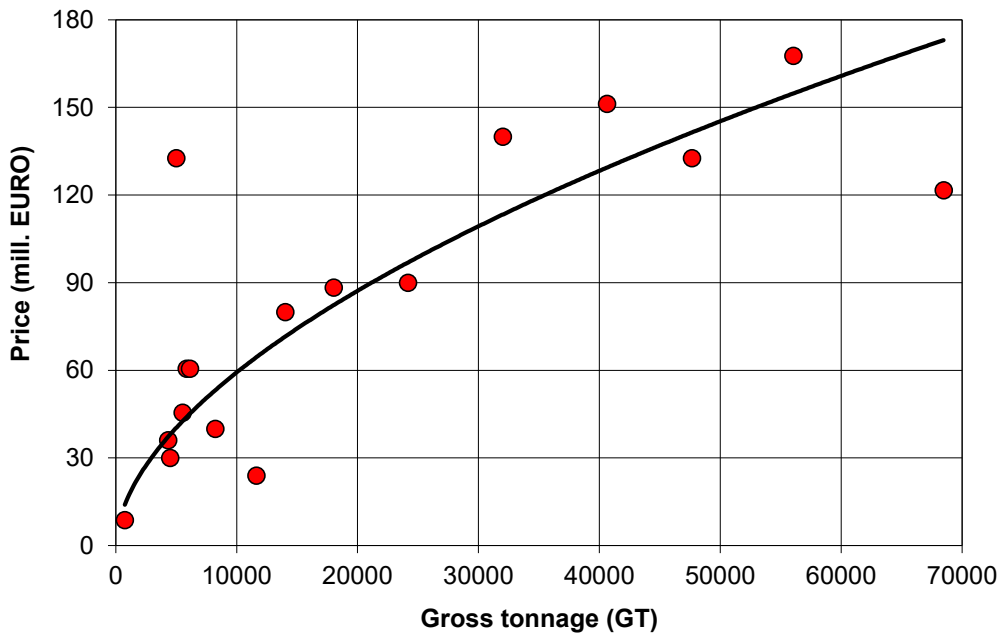

Figure 70 Newbuilding prices for Ro-Ro passenger ships

For Ro-Ro cargo ships it is also very complex to find a price calculation formula, which takes care of the individuality of these ships. In consultation with a large ferry operator and a ship design consultancy, the price for a Ro-Ro cargo ferry is assumed to be approximately 50 % lower than for a Ro-Ro passenger ferry, due to much less passenger accommodation and associated equipment.

#### CAPEX Fast car carrying catamarans

Not many newbuilding prices are available for this class of passenger ships. For the last high-speed craft delivered to Bornholmsslinjen, Express 5, (with a total capacity of 451 cars) the official price of that vessel has been released to be 83.6 mill. EURO. Assuming that 25 % of this price is independent of the car capacity, while the remaining 75 % of the price varies linearly with the car capacity following formula is used for calculation of the price of a car carrying fast catamaran ferry:

$$\text{Price (mill. EURO)} = 83.64 \cdot 0.25 + 83.63 \cdot 0.75 \cdot \text{car capacity}/451 = 20.9 + 0.139 \cdot \text{car capacity}$$

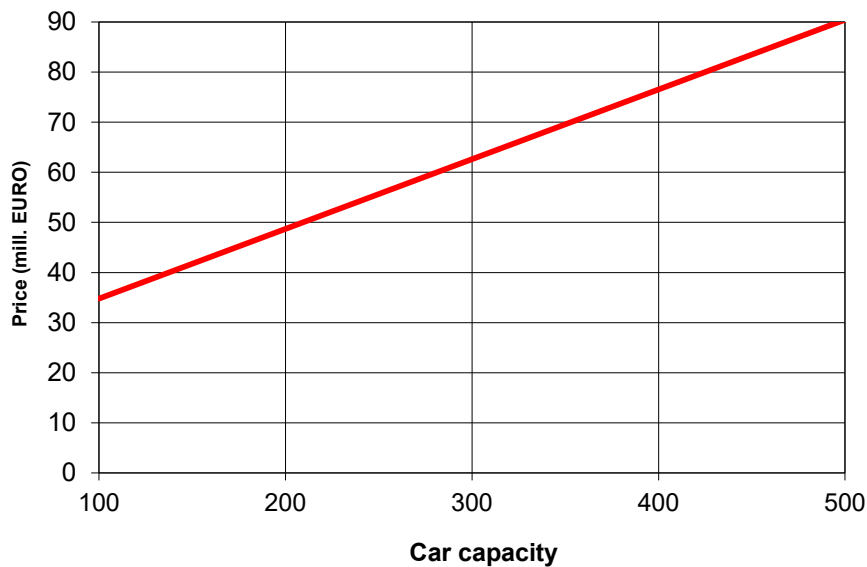

Figure 71 Newbuilding prices for fast car carrying catamarans

### CAPEX Small ferries

Small inland water ferries is a sub segment of passenger ferries compared with the Ro-Ro passenger ships described in this report. The accommodation of small ferries is more simple and limited. As example there are often no normal cafeteria facilities due to the short sailing distance for many of these ferries. The prices must be calculated by some other formulas than for Ro-Ro passenger ships. In a previous investigation (COWI, 2021) COWI has established some price calculation formulas, which have been modified for this project due to the increase of newbuilding prices during the last 2 – 3 years, which is 25 – 30 pct. according to discussions with some shipyards. Assuming a price increase of 30 pct. following modified formulas have been established:

#### Conventional ferries:

- Less than 10: Cars:  $Price (mill. EURO) = 0.35 \cdot PCU + 4.3$
- 10 – 40 cars:  $Price (mill. EURO) = 0.066 \cdot PCU + 7.2$
- More than 40 cars:  $Price (mill. EURO) = 0.23 \cdot PCU + 0.94$

#### Electrical ferries:

- Less than 10: Cars:  $Price (mill. EURO) = 0.435 \cdot PCU + 4.3 + battery price$
- 10 – 40 cars:  $Price (mill. EURO) = 0.11 \cdot PCU + 7.6 + battery price$
- More than 40 cars:  $Price (mill. EURO) = 0.26 \cdot PCU + 6.3 + battery price$

### Fixed O&M

Due to large variation for each individual ship, it has not been possible to determine the fixed operations and maintenance costs in this version of the catalogue.

## Variable O&M (€/nm)

Due to large variation for each individual ship, it has not been possible to determine the variable operations and maintenance costs in this version of the catalogue.

## 8. References

- Breslin, S. a. (1994). *Hydrodynamics of Ship Propellers*. Cambridge: Cambridge University Press.
- Bui, Q. K., Perera, L., & Emblemståv, J. (2022). Life-cycle cost analysis of an innovative marine dual-fuel engine under uncertainties. *Journal of Cleaner Production*, 380(2).
- COWI. (2021). *Grøn omstilling af danske indenrigsfærger*. Copenhagen: COWI for Transport- og Boligministeriet. Retrieved from <https://www.trm.dk/publikationer/2021/faergeanalyse-groen-omstilling-af-danske-indenrigsfaerger/>
- Danish Energy Agency. (2018). *Technology data for energy storage*. Danish Energy Agency and Energinet.
- Davies, D., & et al. (2019). Combined economic and technological evaluation of battery energy storage for grid applications. *Nature Energy*, 4(1).
- DNV. (2023). *Energy Transition Outlook 2023. Maritime Forecast to 2050. A deep dive into shipping's decarbonization journey*.
- DNV. (2023). *Methanol as fuel heads for the mainstream in shipping*. DNV. Retrieved from <https://www.dnv.com/expert-story/maritime-impact/Methanol-as-fuel-heads-for-the-mainstream-in-shipping.html>
- DTU. (2023). *Ship-Desmo Homepage*. Retrieved from DTU, OceanWave : <https://gitlab.gbar.dtu.dk/oceanwave3d/Ship-Desmo>
- Elkafas, A., Rivarolo, M., Gadducci, E., Magistri, L., & Massardo, A. (2023). Fuel Cell Systems for Maritime: A Review of Research Development, Commercial Products, Applications, and Perspectives. *Processes*, 11(1), 97.
- EMSA. (2022). *Update on potential of biofuels in shipping*. Lisbon: European Maritime Safety Agency.
- European Commission. (2021). *Regulation of the European Parliament and of the council on the use of renewable and low-carbon fuels in maritime transport and amending Directive 2009/16/EC*. Brussels.
- European Maritime Safety Agency. (2022). *Potential of ammonia as fuel in shipping*. Lisbon: EMSA.
- Førby, N., & et al. (2023). Ignition and combustion study of premixed ammonia using GDI pilot injection in CI engine. *Fuel*, 331. *DTU Ammoko project*.

- Global Maritime Forum. (2023). *NoGAPS: Nordic Green Ammonia Powered Ships. Phase 2 report: Commercialising early ammonia-powered vessels*. Nordic Innovation.
- HANSA. (2023a, May). Die erste Fähre mit Wasserstoffantrieb. *International Maritime Journal*.
- HANSA. (2023b, 07). Märkte - Markets. *International Maritime Journal*.
- Harmsen, J. (2021). *Green Maritime Methanol. Towards a zero emission shipping industry*. TNO Publications.
- ICCT. (2017). *Greenhouse Gas Emissions from Global Shipping, 2013-2015*. ICCT .
- IEA. (2020). *IEA-Advanced Motor Fuels Annual Report*. IEA.
- IMO. (2022). *MEPC 79/15/Add.1, Annex 9. 2022 Guidelines on the method of calculation of the attained energy efficiency design index (EEDI) for new ships*. IMO.
- IMO. (2023). *Intersessional meeting of the working group on reduction of GHG emissions from ships. Annex 2. Europe: Commercial readiness of absolute zero GHG technologies*. Retrieved from [https://www.un.org/Depts/los/consultative\\_process/icp23/MacLaineAnnex2.pdf](https://www.un.org/Depts/los/consultative_process/icp23/MacLaineAnnex2.pdf)
- IMO. (2023, May 12). *MacLaine Annex2. Reduction of GHG emissions from ships. Commercial readiness of absolute zero GHG technologies*. Retrieved from International Maritime Organisation: [https://www.un.org/Depts/los/consultative\\_process/icp23/MacLaineAnnex2.pdf](https://www.un.org/Depts/los/consultative_process/icp23/MacLaineAnnex2.pdf)
- Insel, M. (1992). *An Investigation into the Resistance Components of High Speed Displacement Catamarans*. RINA Transaction.
- IPCC. (2013). *The Physical Science Basis. Contribution of Working Group I to the Fifth Assessment Report of the Intergovernmental Panel on Climate Change*. Stocker, T.F., D. Qin, G.K. Plattner, M. Tignor, S.K. Allen, J. Boschung.
- Kristensen, H. (2015). *Analysis of technical data of Ro-Ro ships. Project no. 2014-122: Mitigating and reversing the side-effects of environmental legislation on Ro-Ro shipping in Northern Europe*. Lyngby: DTU Report.
- Kristensen, H. (2015). *Energy demand and exhaust gas emissions of marine engines. Project no. 2014-122: Mitigating and reversing the side-effects of environmental legislation on Ro-Ro shipping in Northern Europe*. Lyngby: DTU Report.
- Kristensen, H. (2016). *Analysis of propulsion power data of Ro-Ro ships and analysis of the CEN standard 16258 for Ro-Ro ships. Project no. 2014-122: Mitigating and reversing the side-effects of environmental legislation on Ro-Ro shipping in Northern Europe*. Lyngby: DTU Report.
- Kristensen, H. (2016). *Prediction of resistance and propulsion power of Ro-Ro ships. Project no. 2014-122: Mitigating and reversing the side-effects of environmental legislation on Ro-Ro shipping in Northern Europe*. Lyngby: DTU Report.

- Kristensen, H. (2017). *Energy demand and exhaust gas emissions of marine engines. Project no. 2016-108: Update of decision support system for calculation of exhaust gas emissions.* Lyngby: DTU Report.
- Kristensen, H. (2017). *Prediction of Resistance and Propulsion Power of Ships. Project no. 2016-108: Update of decision support system for calculation of exhaust gas emissions.* Lyngby: DTU Report.
- Kristensen, H. (2017). *Revision of statistical analysis and determination of regression formulas for main dimensions of bulk carriers based on data from Clarkson. Project no. 2016-108: Update of decision support system for calculation of exhaust gas emissions.* . Lyngby: DTU Report.
- Kristensen, H. (2017). *Revision of statistical analysis and determination of regression formulas for main dimensions of container ships based on data from Clarkson. Project no. 2016-108: Update of decision support system for calculation of exhaust gas emissions.* Lyngby: DTU Report.
- Kristensen, H. (2017). *Revision of statistical analysis and determination of regression formulas for main dimensions of tankers based on data from Clarkson. Project no. 2016-108: Update of decision support system for calculation of exhaust gas emissions.* . Lyngby: DTU Report.
- Kristensen, H. (2023). *Description and documentation of a power prediction method for fast car carrying catamaran ferries included in the generic ship design model SHIP-DESMO.* DTU Report.
- Kristensen, H. (2023). *Description and documentation of a power prediction method for small inland waterway ferries included in the generic ship design model SHIP-DESMO.*
- Latarche, M. (2023). Ammonia grabs the headlines and a recycling ramp up is needed. *The Naval Architect*(June 2023).
- Lloyds Register of Shipping. (1995). *Marine Exhaust Emissions Research Programme.*
- Maersk. (2022, October 5). Retrieved from Maersk Press releases: <https://www.maersk.com/news/articles/2022/10/05/maersk-continues-green-transformation>
- MAN Energy Solutions. (2019). *MAN Energy Solution (2019): Batteris on board ocean-going vessels.* Retrieved from MAN Energy Solution (2019): Batteris on board ocean-going vessels.: [man-es.com/docs/default-source/marine/tools/batteries-on-board-ocean-going-vessels.pdf?sfvrsn=deaa76b8\\_14](https://man-es.com/docs/default-source/marine/tools/batteries-on-board-ocean-going-vessels.pdf?sfvrsn=deaa76b8_14)
- MAN Energy Solutions. (2023). *Marine engine programme.* 2nd edition.
- MAN Energy Solutions. (n.d.). *EEDI.* Retrieved from [https://man-es.com/docs/default-source/document-sync-archive/eedi-eng.pdf?sfvrsn=23fbab95\\_4](https://man-es.com/docs/default-source/document-sync-archive/eedi-eng.pdf?sfvrsn=23fbab95_4)
- Mærsk Mc-Kinney Møller Center. (2023). *Managing emissions from ammonia-fueled vessels. an overview of regulatory drivers, emission types, sources, scenarios, reduction technologies, and solutions.* Mærsk Mc-Kinney Møller Ceter for Zero Carbon Shipping.

- Mærsk Mc-Kinney Møller Center. (2023). *Nordic Green Ammonia Powered Ships (NoGAPS). Feasibility assessment of an ammonia-fueled gas carrier design*. Mærsk Mc-Kinney Møller Center for Zero Carbon Shipping. Nordic Innovation.
- Nadimi, E., & et al. (2023). Effects of ammonia on combustion, emissions, and performance of the ammonia/diesel dual-fuel compression ignition engine. *Journal of the Energy Institute*, 107.
- Padeti, J. K. (2022). *The Role of Methanol as a Marine Fuel: Today and in the future*. *Proceedings of the Marine Safety & Security Council*, 79(2). . Coast Guard Journal of Safety & Security at Sea.
- Pratt, J. (2022). *Hydrogen and Fuel Cell Technology Is Poised to Transform the US Maritime Industry*. , *Proceedings of the Marine Safety & Security Council*, 79(2). . Coast Guard Journal of Safety & Security at Sea.
- RINA. (2018). *Significant Small Ships*. The Royal Institution of Naval Architects (RINA).
- State of California. (2023). *LCTI: Zero-Emission Hydrogen Ferry Demonstration Project*. Retrieved from Advanced Technology Demonstration and Pilot Projects: <https://ww2.arb.ca.gov/lcti-zero-emission-hydrogen-ferry-demonstration-project>
- Switch. (2023). *Projects*. Retrieved from Sea Change: <https://www.switchmaritime.com/projects>
- Van Oosanen, P. (1980). *Resistance Prediction of Small High Speed Displacement Vessels*. *International Shipbuilding Progress* Vol 27, No 313.
- Zhao, Y., Li, M., Wang, Z., Xu, G., & Yuan, Y. (2019). Effects of exhaust gas recirculation on the functional groups and oxidation characteristics of diesel particulate matter. *Powder Technology*, 346, 265-272.