

# Technology Data

## Heating installations

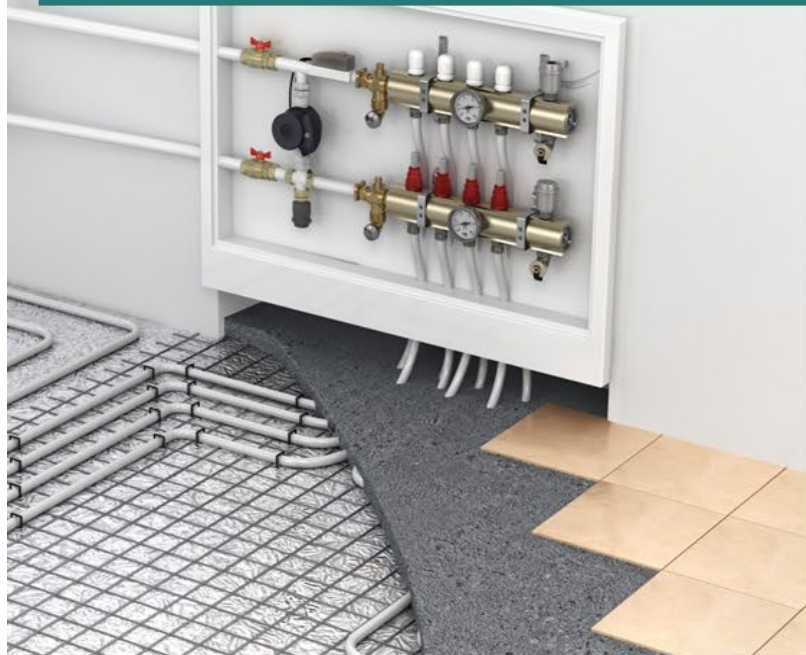

Energistyrelsen  
Danish Energy Agency

Technology descriptions  
and projections for long-term  
energy system planning

**Technology Data for heating installations**

First published 2016 by the Danish Energy Agency and Energinet,

E-mail: [ens@teknologikatalog.dk](mailto:ens@teknologikatalog.dk), Internet: <http://www.ens.dk/teknologikatalog>

Production: Danish Energy Agency

Front page design: Filip Gamborg

Front cover photo: Colourbox.dk

Version number: 0004

## Amendment sheet

### Publication date

Publication date for this catalogue “Technology Data for Individual Heating Plants and Energy Transport” is august 2016. A comprehensive review and update of the catalogue has been carried out during Q4 of 2020.

The newest version of the catalogue will always be available from the Danish Energy Agency’s web site.

### Amendments after publication date

All updates made after the publication date will be listed in the amendment sheet below.

---

Date	Ref.	Description
24-08-2022	207	Updated the chapter to more clearly convey the SCOP value
24-06-2021	208	Added new chapter on hybrid heat pumps
24-06-2021	207	Capacity of heat pumps have been revised to match heat capacity assessed at -7/55 °C
20-01-2021		Comprehensive update has been undertaken during Q4 of 2020. Primary focus is on data sheets, but text has been revised as well.

---

### Preface

The *Danish Energy Agency* publishes catalogues containing data on technologies for individual heating. The first edition of the catalogue was published in 2016. This current catalogue includes updates of several technologies. The catalogue will continuously be updated as technologies evolve if data change significantly or if errors are found. All updates will be listed in the amendment sheet on the previous page and in connection with the relevant chapters, and it will always be possible to find the most recently updated version on the Danish Energy Agency's website.

The primary objective of publishing technology catalogues is to establish a uniform, commonly accepted and up-to-date basis for energy planning activities, such as future outlooks, evaluations of security of supply and environmental impacts, climate change evaluations, as well as technical and economic analyses, e.g. on the framework conditions for the development and deployment of certain classes of technologies.

With this scope in mind, it is not the target of the technology data catalogues, to provide an exhaustive collection of specifications on all available incarnations of energy technologies. Only selected, representative, technologies are included, to enable generic comparisons of technologies with similar functions.

Finally, the catalogue is meant for international as well as Danish audiences in an attempt to support and contribute to similar initiatives aimed at forming a public and concerted knowledge base for international analyses and negotiations.

### Danish preface

Energistyrelsen udarbejder teknologibeskrivelser for en række teknologier til brug for individuel opvarmning. Første udgave af kataloget blev offentliggjort i 2016. Dette nuværende katalog indeholder opdateringer af en stor del af teknologibeskrivelserne. Kataloget vil løbende opdateres i takt med at teknologierne udvikler sig, hvis data ændrer sig væsentligt eller hvis der findes fejl. Alle opdateringer vil registreres i rettelsesbladet først i kataloget, og det vil altid være muligt at finde den seneste opdaterede version på Energistyrelsens hjemmeside.

Hovedformålet med teknologikataloget er at sikre et ensartet, alment accepteret og aktuelt grundlag for planlægningsarbejde og vurderinger af forsyningssikkerhed, beredskab, miljø og markedsudvikling hos bl.a. de systemansvarlige selskaber, universiteterne, rådgivere og Energistyrelsen. Dette omfatter for eksempel fremskrivninger, scenarieforskelser og teknisk-økonomiske analyser.

Desuden er teknologikataloget et nyttigt redskab til at vurdere udviklingsmulighederne for energisektorens mange teknologier til brug for tilrettelæggelsen af støtteprogrammer for energiforskning og -udvikling. Tilsvarende afspejler kataloget resultaterne af den energirelaterede forskning og udvikling. Også behovet for planlægning og vurdering af klima-projekter har aktualiseret nødvendigheden af et opdateret databeredskab.

Endeligt kan teknologikataloget anvendes i såvel nordisk som internationalt perspektiv. Det kan derudover bruges som et led i en systematisk international vidensopbygning og -udveksling, ligesom kataloget kan benyttes som dansk udspil til teknologiske forudsætninger for internationale analyser og forhandlinger. Af disse grunde er kataloget udarbejdet på engelsk.

**Table of contents**

Guideline/Introduction.....7

201 Oil boiler (including bio oil) ..... 24

202 Gas boiler..... 31

203 District heating substation ..... 41

204 Biomass boiler, automatic stoking ..... 47

205 Biomass boiler manual stoking..... 52

206 Wood stove..... 56

207 Electric heat pumps, air-to-water, brine-to-water, air-to-air and ventilation ..... 61

208 Hybrid gas and electric heat pump..... 90

215 Solar heating system ..... 101

216 Electric heating ..... 106

### Guideline/Introduction

This catalogue presents technologies for heating installations used in buildings and households. Some of the technologies presented, besides heating, also produce electricity which will either be consumed at a household level or fed to the grid. Some technologies are presented for different sizes and/or for existing and new buildings. The section Definitions defines sizes and types of buildings and describes the specific assumptions.

The main purpose of the catalogue is to provide generalized data for analysis of energy systems, including economic scenario models and high-level energy planning.

These guidelines serve as an introduction to the presentations of the different technologies in the catalogue, and as instructions for the authors of the technology chapters. The following sections (Qualitative description and Quantitative description) explain the formats of the technology chapters, how data were obtained, and which assumptions they are based on. Each technology is subsequently described in a separate technology chapter, making up the main part of this catalogue. The technology chapters contain both a qualitative description of the technologies and a quantitative part including a table with the most important technology data. Quantitative data is published in separate Excel file for Data sheets.

Under the energy-related products directive (ErP) (previously the ECO-design directive) extensive guidelines and methodologies have been developed to assess the energy performance of a large number of different heating technologies [11]. Thus, the ErP provides a valuable resource for the authors of the technology chapters, and for readers who seek more detailed data for specific technologies.

### Qualitative description

The qualitative description describes the key characteristics of the technology as concise as possible. The following paragraphs are included where relevant for the technology.

#### Contact information

Containing the following information:

- Contact information: Contact details in case the reader has clarifying questions to the technology chapters. This could be the Danish Energy Agency, Energinet.dk or the author of the technology chapters.
- Author: Entity/person responsible for preparing the technology chapters

Comments, criticisms or suggestions for changes can be sent to [teknologikatalog@ens.dk](mailto:teknologikatalog@ens.dk).

#### Brief technology description

Brief description for non-engineers of how the technology works and for which purpose. An illustration of the technology is included, showing the main components and working principles. As a default any heating installation includes a storage water tank unless otherwise specified in the brief technology description. Hence, unless otherwise noted in this section, the data from the datasheet always includes a hot water storage tank.

#### Input

The main raw materials and/or energy carriers, e.g. fuels, used by the technology.

### Output

The forms of generated energy i.e. heat.

### Typical capacities

The stated capacities are for a single unit or, in case of e.g. solar heating, for a typical system size. This section includes a description of the relevant product range(s) in capacity (kW).

### Regulation ability

Description of how the unit can regulate, e.g. a gas boiler is very flexible whereas a solar heating system depends on the solar radiation.

Regulation abilities are particularly relevant for electricity generating and consuming technologies. This includes the part-load characteristics, start-up time and how quickly it is able to change its production or consumption when already online.

### Advantages/disadvantages

A description of specific advantages and disadvantages relative to equivalent technologies. Generic advantages are ignored; e.g. renewable energy technologies mitigating climate risks and enhance security of supply.

### Environment

Particular environmental characteristics are mentioned, for example special emissions or the main ecological footprints. The scope of this footprint ranges from production of materials and fuel to decommissioning of the installation.

### Research and development perspectives

This section lists the most important challenges to further development of the technology in the context of this catalogue: Heating supply of buildings in Denmark. Also, the potential for technological development in terms of costs and efficiency is mentioned and quantified if possible. Danish research and development perspectives are highlighted, where relevant.

### Examples of market standard technology

Recent commercially available units, which can be considered market standard, are mentioned, preferably with links. If possible, this list includes at least three examples from different suppliers. A description of what is meant by “market standard” is given in the introduction to the Quantitative description. For technologies where no market standard has yet been established, reference is made to best available technology in R&D projects.

### Prediction of performance and costs

Cost reductions and improvements of performance can be expected for most technologies in the future. This section accounts for the assumptions underlying the cost and performance in 2020 as well as the improvements assumed for the years, 2025, 2030, 2040 and 2050. The specific technology is identified and classified in one of four categories of technological maturity, indicating the commercial and technological progress, and the assumptions for the projections are described in detail.

In some cases, new technological developments might substantially change the function and/or efficiency of a technology, for example by a radically new design or by using a new material with better properties. This can



happen to such a degree that it is more reasonable to talk about a technology jump, rather than a technological improvement or development. In this case, it is recommended to create a new data-sheet for the substantially changed technology, rather than simply updating the technology with the new values, in order to avoid confusion about radically different data sheets from one year to the next.

The following background information is considered:

### *Data for 2020*

In case of technologies where market standards have been established, performance and cost data of recent installed versions of the technology in Denmark or the most similar countries in relation to the specific technology in Northern Europe are used for the 2020 estimates.

If consistent data are not available, or if no suitable market standard has yet emerged for new technologies, the 2020 costs may be estimated using an engineering-based approach applying a decomposition of manufacturing and installation costs into engineering components, labour costs, financial costs, etc.

### *Assumptions for the period 2030 to 2050*

According to the IEA [3]:

*“Innovation theory describes technological innovation through two approaches: the technology-push model, in which new technologies evolve and push themselves into the marketplace; and the market-pull model, in which a market opportunity leads to investment in R&D and, eventually, to an innovation”*

The level of “market-pull” is to a high degree dependent on the global climate and energy policies. Hence, in a future with strong climate policies, demand for e.g. renewable energy technologies will be higher, whereby innovation is expected to take place faster than in a situation with less ambitious policies. This is expected to lead to both more efficient technologies, as well as cost reductions due to economy of scale effects. Therefore, for technologies where large cost reductions are expected, it is important to account for assumptions about global future demand.

The IEA’s Stated Policies Scenario provides the framework for the Danish Energy Agency’s projection of international fuel prices and CO<sub>2</sub>-prices and is also used in the preparation of this catalogue. Thus, the projections of the demand for technologies are defined in accordance with the thinking in the Stated Policies Scenario, described as follows [ref. 4]:

*“[The Stated Policies Scenario] is designed to reflect the impact not just of existing policy frameworks, but also of today’s stated policy plans. The name [...] underlines that this scenario considers only those policy initiatives that have already been announced. The aim is to hold up a mirror to the plans of today’s policy makers and illustrate their consequences, not to guess how these policy preferences may change in the future.”*

Alternative projections may be presented as well relying for example on the IEA’s Sustainable Development Scenario (strong climate policies) or the IEA’s Current Policies Scenario (weaker climate policies).

### 1) *Learning curves and technological maturity*

Predicting the future costs of technologies may be done by applying an engineering-based approach, as mentioned above, decomposing the costs of the technology into categories such as labour, materials, etc. for which predictions already exist. Alternatively, the development could be predicted using learning curves. Learning curves express the concept that each time a unit of a particular technology is produced, learning accumulates, which leads to cheaper production of the next unit of that technology. The learning rates also consider benefits from economy of scale and benefits related to using automated production processes at high production volumes.

The potential for improving technologies is linked to the level of technological maturity. The technologies are categorized within one of the following four levels of technological maturity in Denmark. As an example, fuel cell mCHP is in widespread use in Japan, but is only installed in limited no. in Europe. Hence, in a Danish context, mCHP is considered a technology in the pioneer phase.

Category 1. Technologies that are still in the *research and development phase*. The uncertainty related to price and performance today and in the future, is highly significant.

Category 2. Technologies in the *pioneer phase*. The technology has been proven to work through demonstration facilities or semi-commercial plants. Due to the limited application, the price and performance is still associated with high uncertainty since development and customization is still needed. The technology still has a significant development potential.

Category 3. *Commercial technologies with moderate deployment*. The price and performance of the technology today is well known. These technologies are deemed to have a certain development potential and therefore there is a considerable level of uncertainty related to future price and performance (e.g. solar heating or electric heat pumps)

Category 4. *Commercial technologies, with large deployment*. The price and performance of the technology today is well known, and normally only incremental improvements would be expected. Therefore, the future price and performance may also be projected with a relatively high level of certainty. (e.g. gas boilers & district heating units)

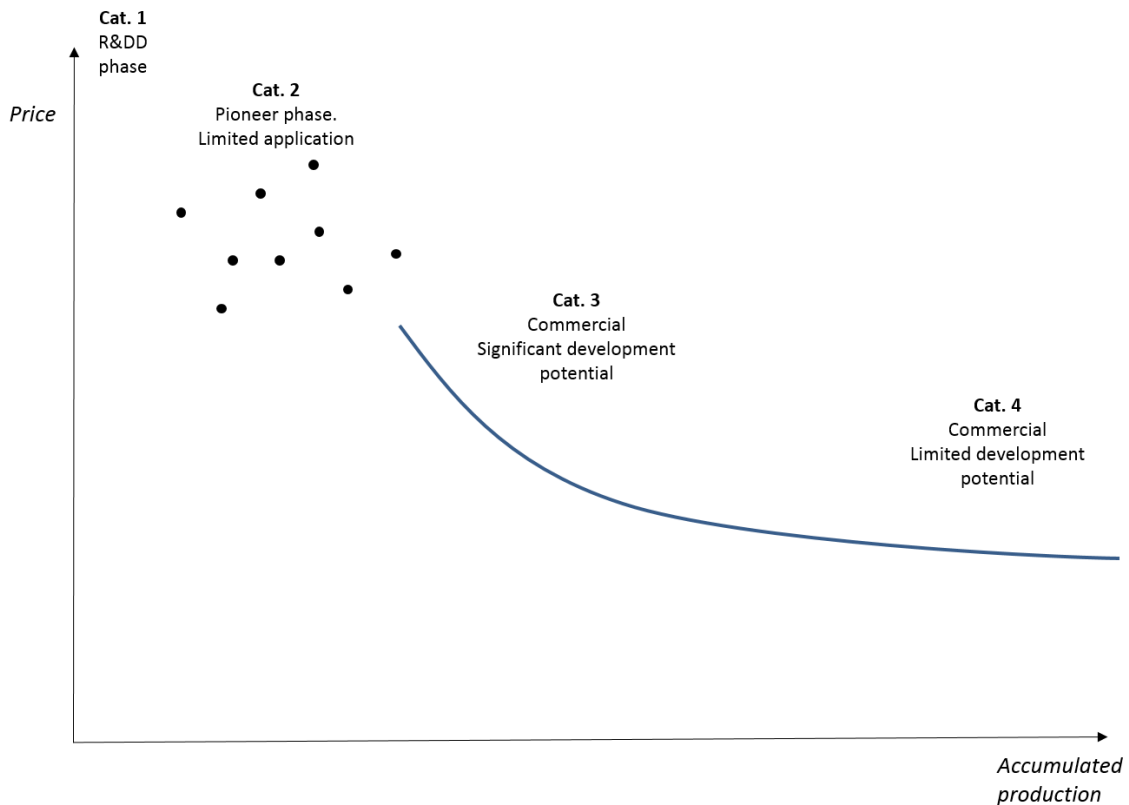

Figure 1 Technological development phases. Correlation between accumulated production volume (MW) and price.

**Uncertainty**

This catalogue covers both mature technologies and technologies under development. This implies that the price and performance of some technologies may be estimated with a relatively high level of certainty whereas in the case of others, both cost and performance today as well as in the future are associated with high levels of uncertainty.

This section of the technology chapters explains the main challenges to precision of the data and identifies the areas on which the uncertainty ranges in the quantitative description are based. This includes technological or market related issues of the specific technology as well as the level of experience and knowledge in the sector and possible limitations on raw materials. The issues should also relate to the technological development maturity as discussed above.

The level of uncertainty is illustrated by providing a lower and higher bound beside the central estimate, which shall be interpreted as representing probabilities corresponding to a 90% confidence interval. It should be noted, that projecting costs of technologies far into the future is a task associated with very large uncertainties. Thus, depending on the technological maturity expressed and the period considered, the confidence interval may be very large. It is the case, for example, of less developed technologies (category 1 and 2) and long-time horizons (2050).

### Economy of scale effects

The per unit cost of larger units are usually less than that of smaller plants. Similarly, there is a per unit cost reduction due to mass production. This is called the ‘economy of scale’. This section assesses the economy of scale effect for the specific technology, preferably by means of examples.

### Additional remarks

This section includes other information, for example links to websites that describe the technology further or give key figures on it.

### References

References are numbered in the text in squared brackets and bibliographical details are listed in this section. It is important that sources used are referenced in a way that they can be found by the reader, i.e. that both the full title of the report, together with author and year where applicable, and a direct link are provided. Reference numeration between references used in the qualitative and the quantitative descriptions must be consistent.

### Quantitative description

To enable comparative analyses between different technologies it is imperative that data are comparable: All cost data are stated in fixed 2020 prices excluding value added taxes (VAT) and other taxes. The information given in the tables relate to the development status of the technology at the point of final investment decision (FID) in the given year (2020, 2025, 2030, 2040 and 2050). FID is assumed to be taken when financing of a project is secured, and all permits are at hand. The year of commissioning will depend on the construction time of the individual technologies.

A typical table of quantitative data is shown below, containing all parameters used to describe the specific technologies. The datasheet consists of a generic part, which is identical for all technologies and a technology specific part, containing information, which is not relevant for all technologies. The generic part is made to allow for easy comparison of technologies.

Each cell in the table contains only one number, which is the central estimate for the market standard technology, i.e. no range indications.

Uncertainties related to the figures are stated in the columns named *uncertainty*. To keep the table simple, the level of uncertainty is only specified for years 2025 and 2050.

The level of uncertainty is illustrated by providing a lower and higher bound. These are chosen to reflect the uncertainties of the best projections by the authors. The section on uncertainty in the qualitative description for each technology indicates the main issues influencing the uncertainty related to the specific technology. For technologies in the early stages of technological development or technologies especially prone to variations of cost and performance data, the bounds expressing the confidence interval could result in large intervals. The uncertainty only applies to the market standard technology; in other words, the uncertainty interval does not represent the product range (for example a product with lower efficiency at a lower price or vice versa). The level of uncertainty is stated for the most critical figures such as investment cost and efficiencies. Other figures are considered if relevant.

All data in the tables are referenced by a number in the utmost right column (Ref), referring to source specifics below the table. The following separators are used:

- ; (semicolon) separation between the four time horizons (2020, 2025, 2030, 2040, and 2050)
- / (forward slash) separation between sources with different data
- + (plus) agreement between sources on same data

Notes include additional information on how the data are obtained, as well as assumptions and potential calculations behind the figures presented. Before using the data, please be aware that essential information may be found in the notes below the table.

### Energy/technical data

The generic parts of the datasheets for individual heating technologies are presented below:

#### Heat production and power generation capacity for one unit

The heat production capacities, preferably typical capacities (not maximum capacities), are stated for a single unit or, in case of e.g. solar heating, for a typical system size.

Any auxiliary electricity consumption for pumps etc. is not counted in the capacity.

The unit kW is to determine heat production capacity.

The relevant range of sizes of each type of technology is represented by a range of capacities stated in the notes for the “capacity” field in each technology table.

#### Energy efficiencies

Efficiencies for all heating plants are expressed in decimal (p.u.) at lower calorific heat value (lower heating value) at ambient conditions in Denmark, considering an average air temperature of approximately 8 °C. Efficiencies are calculated under the assumption of a correct installation. For some technologies this matters less, whereas for other technologies, such as heat pumps, the quality of the installation can have a substantial effect on the efficiency and should be discussed where relevant.

The evaluations of the energy efficiencies of the technologies described in the Technology Catalogue, may inspire from the methodologies from the energy-related products directive s developed by the EU Commission.

The loss from the storage tank is included in the calculation of the efficiency under the assumption that 50% of heat loss is recuperated. The impact on the total efficiency therefore depends on the size of the storage tank. Some heating installations do not necessarily use a storage tank, when this is the case, this is explicitly specified in the notes.

The heat efficiency equals the net delivery of heat divided by the fuel consumption. The auxiliary electricity consumption is not included in the heat efficiency but stated separately in kWh/year.

For heat pumps, a fuel efficiency of for example 300 % represents a COP of 3.

The energy supplied by the heat source for heat pumps (both electric and absorption) is not counted as input energy. The temperatures of the heat source are specified in the specific technology chapters.

If nothing else is stated in the technology description, the heat efficiency reflects the total heat efficiency covering both space heating and hot tap water.

The efficiencies reflect annual average efficiencies as experienced by the consumer, assuming that the heat installations are installed correctly. The boundary of annual efficiency is shown in the figure below.

Often, the efficiencies decrease slightly during the operating life of a plant. This degradation is not reflected in the stated data, and users will have to make such corrections themselves, based on their assumptions about the rate of deterioration of the technology. As a rule of thumb 2.5 – 3.5 %-points may be subtracted during the lifetime (e.g. from 90 % to 87 %).

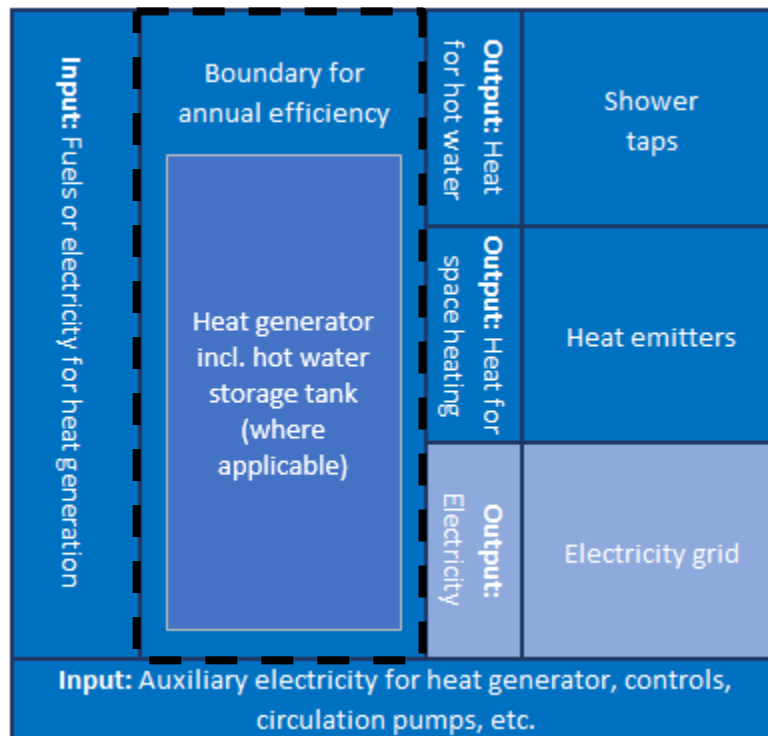

**Figure 2** The dotted line shows the boundary for annual efficiency

**Expected share of demand covered by unit**

The expected share of total demand, both for space heating and for tap water, covered by the technology is specified in decimal (p.u.).

**Auxiliary electricity consumption**

A specification of the annual auxiliary electricity demand for the heat installation is given in kWh/year. It accounts for the consumption of electricity from auxiliary systems such as circulation pumps, other pumps, ventilation systems, controls etc. For heat pumps, internal consumption (inside the unit) is considered part of the efficiency (coefficient of performance, COP), while other electricity demand for external pumping is stated under auxiliary electricity consumption. The auxiliary electricity consumption is not included in the efficiencies, as it is possible to see from the boundaries in Figure 2.

### Lifetime

The lifetime is defined as the technical-economic lifetime [5], which refers to the expected time for which an energy plant can be operated within, or acceptably close to, its original performance specifications, provided that normal operation and maintenance takes place. As such, the technical-economic lifetime of the technology is found by comparing the on-going costs of repairing and maintaining against the expected costs of re-investing in a similar technology. This should not be mistaken with economic lifetime, which instead evaluates the alternative cost of competing technologies.

During this lifetime, some performance parameters may degrade gradually but still stay within acceptable limits. For instance, efficiencies often decrease slightly (few percent) over the years, and O&M costs increase due to wear and degradation of components and systems.

Towards the end of the technical-economic lifetime, the frequency of unforeseen operational problems and risk of breakdowns is expected to lead to unacceptably low availability and/or high O&M costs. At this time, the installation is decommissioned or undergoes a lifetime extension, which implies a major renovation of components and systems as required to make the installation suitable for a new period of continued operation. The technical-economic lifetime stated in this catalogue is, therefore, a value inherent to each technology and based on experience. If possible, the lifetime is based on statistics/studies done on appliances lifetime. The expected technical-economic lifetime takes into account a typical number of start-ups and shut-downs.

In practice, specific plants of similar technology may operate for shorter or longer times. The strategy for operation and maintenance, e.g. the number of operation hours, start-ups, and the reinvestments made over the years, will have a large influence on the actual lifetime.

### Electric regulation ability

This section is only relevant for power consuming technologies. Three parameters describe the electricity regulation capability of the technologies:

- A. Primary regulation (% per 30 seconds): frequency control
- B. Tertiary regulation (% per minute): balancing power
- C. Minimum load (percent of full load).

For several technologies, these parameters are not relevant, e.g. if the technology is regulated solely in on/off-mode.

Parameters A and B are the ability to regulate when the technology is already in operation.

### Environment

All plants are assumed to be designed to comply with the regulation that is currently in place in Denmark and planned to be implemented within the 2025 time-horizon.

The emissions below are stated in mass per GJ of fuel at the lower heating value.

**CO<sub>2</sub> emission** values are not stated, as these depend only on the fuel, not the technology.

**SO<sub>x</sub> emissions** are expressed in grams per GJ of fuel.

$\text{NO}_x$ .  $\text{NO}_x$  equals  $\text{NO}_2 + \text{NO}$ , where  $\text{NO}$  is converted to  $\text{NO}_2$  in weight-equivalents.

**Particles** includes the fine particle matters (PM 2.5). The value is given in grams per GJ of fuel.

The emissions of  $\text{CH}_4$  and  $\text{N}_2\text{O}$  can be converted to  $\text{CO}_2$ -equivalents by multiplying the  $\text{CH}_4$  emission by 25 and the  $\text{N}_2\text{O}$  emission by 298.

### Financial data

Financial data are all in Euro (€), fixed prices, at the 2020-level and exclude value added taxes (VAT) and other taxes. Several data originate in Danish references. For those data, a fixed exchange ratio of 7.45 DKK per € has been used.

### Investment costs

The investment cost is also called the engineering, procurement, and construction (EPC) price or the overnight cost. Infrastructure and connection costs, i.e. electricity, fuel, and water connections inside the household/building, are also included. The investment cost includes the total costs of establishing the technology for the consumer. Where possible, the investment cost is divided on equipment cost and installation cost. Equipment cost covers the heat generation facility and other major component like water tank and environmental facilities if relevant, whereas installation cost covers counselling on unit design by the installer, grid connection, fittings and commissioning of equipment. The catalogue's investment costs are based on expected average national costs of the technology. However, there may be significant variations in investment and installation costs depending on the location in Denmark. If this is the case, the consultant should specify the impact on the cost in a note to the financial data.

### Technologies and scope of investment

The catalogue is intended to work as a tool for energy planners including municipalities in their assessment, comparison, and identification of future energy solutions for heat production in households etc. Hence, it is important to stress that the specific technical and economic data for each technology presented in the catalogue are not in all cases directly comparable, as data/figures cover different aspects of the energy supply of a building and the needed investment costs, respectively.

Table 1 includes the technologies, the scope of the technology definition used within the catalogue and direct and accompanying investment costs. The aim is to outline the different elements that have to be taken into consideration when using the catalogue data for a fair comparison of technologies. The elements included in the technology data sheets are presented in the fourth column, 'Installation of primary heat production technology'. In the case of existing buildings, the premise for an installation is that there already is a worn-out heating installation in place. The cost of dismantling of the existing heat installation is included for most of the technologies since this is typically part of the installation costs. Additional installation costs covering expenses listed in column 1 – 3 and 5 in table 1 are not included in the data sheets. These accompanying costs are instead listed in table 2 and should be considered when relevant. No cost projections have been made for the cost of accompanying investments. As a rule of thumb, it can be assumed that cost expressed in real terms will decrease by approx. 0.5 per cent per annum due to general improvements in productivity. O&M costs related to service pipes and meters for district heating units and gas boilers are not covered by this catalogue, since these costs are assumed to be covered by the distribution tariff.



### Possible additional investment cost

Where relevant, a line with possible additional specific investment is included in the data sheet. An example of this is fluid-to-water heat pumps in city areas where it is necessary to establish vertical tubes (by use of drilling holes) instead of horizontal tubes.



	Abolition/removal of prior heat production system/unit	Improvements of building envelope	Accompanying heat supply installations	Installation of primary heat production technology – elements included in the technology data sheets	Installation of secondary heat production technology
<b>Oil boiler</b>	Often necessary in existing buildings <ul style="list-style-type: none"> <li>removal of oil tank, etc.</li> </ul>	Existing buildings: not directly needed but in many cases recommendable	<ul style="list-style-type: none"> <li>Water based supply system</li> <li>Oil tank</li> <li>Chimney/flue</li> </ul>	Investment/installation cost of boiler incl. pumps, hot tap water production and hot water tank. Dismantling of existing heat installation.	
<b>Gas boiler</b>	Often necessary in existing buildings <ul style="list-style-type: none"> <li>removal of oil tank etc.</li> </ul>	Existing buildings: not directly needed but in many cases recommendable	<ul style="list-style-type: none"> <li>Water based supply system</li> <li>Service pipe</li> </ul>	Investment/installation cost of boiler incl. pumps, hot tap water production, hot water tank & vent. Dismantling of existing heat installation.	
<b>Biomass boiler</b>	Often necessary in existing buildings <ul style="list-style-type: none"> <li>removal of oil tank, etc.</li> </ul>	Existing buildings: not directly needed but in many cases recommendable	<ul style="list-style-type: none"> <li>Water based supply system</li> <li>Fuel storage facility</li> <li>Chimney/flue</li> </ul>	Investment/installation cost of boiler incl. pumps, hot tap water production and hot water tank. Dismantling of existing heat installation.	
<b>District heating unit</b>	Often necessary in existing buildings <ul style="list-style-type: none"> <li>removal of oil tank, etc.</li> </ul>	Existing buildings: not directly needed but in many cases recommendable	<ul style="list-style-type: none"> <li>Water based supply system</li> <li>Branch pipe</li> </ul>	Investment/installation cost of DH unit incl. pumps, hot tap water production, hot water tank. Dismantling of existing heat installation.	
<b>Electric heat pumps – air/fluid to water</b>	Often necessary in existing buildings <ul style="list-style-type: none"> <li>removal of oil tank, etc.</li> </ul>	Existing buildings: energy saving measures often needed in order to optimise heat pump installation	<ul style="list-style-type: none"> <li>Water based supply system</li> </ul> Existing buildings: measures to reduce radiator temperatures often needed	Investment/installation cost of heat pump incl. pipes, pumps, back-up electric heater, hot tap water production and hot water tank. Dismantling of existing heat installation.	
<b>Electrical heating</b>		Existing buildings: not directly needed but in many cases recommendable		Investment/installation cost of electrical radiators, hot tap water production and hot water tank	
<b>Heat pumps – air to air/ventilation</b>	Often necessary in existing buildings (ventilation heat pump only) <ul style="list-style-type: none"> <li>dismantling of existing boiler,</li> <li>removal of oil tank, etc.</li> </ul>	Existing buildings: energy saving measures often needed in order to optimise heat pump installation	<ul style="list-style-type: none"> <li>Existing buildings: measures to reduce radiator temperatures often needed (ventilation heat pump only)</li> </ul>	Investment/installation cost of heat pump incl. hot water storage tank.	<ul style="list-style-type: none"> <li>Back-up heat e.g. electrical radiators</li> <li>Hot tap water supply needed</li> </ul>
<b>Wood stove</b>			<ul style="list-style-type: none"> <li>Fuel storage facility</li> <li>Chimney/flue</li> </ul>	Investment/installation cost of stove (and water tank). Dismantling of existing stove.	<ul style="list-style-type: none"> <li>Supplementary heat supply system</li> <li>Water heater and possibly storage</li> </ul>
<b>Solar heating</b>		In some cases, improvement of roof construction		Investment/installation cost of panel incl. pipes, pumps and hot tap water tank	<ul style="list-style-type: none"> <li>Supplementary heat supply system and water heater and possibly storage</li> </ul>

Table 1 Overview of investment costs included in technology data sheets and possible accompanying investment costs

Table 2 shows some of the general costs of needed accompanying investment (presented in the first three columns in table 2), which potentially could be added when comparing the different technology solutions.

Accompanying element	Costs (EUR2020)	
<b>Dismantling of existing boiler</b> (Note: this is part of installation costs for most technologies, see <b>Table 1</b> )	Single-family houses: Wall hung natural gas fired boiler: 2,100 DKK ex. VAT	300 EUR
	Floor standing oil-fired boiler: 3,200 DKK ex. VAT	440 EUR
<b>Removal of oil tank</b>	Single-family houses: 1,200 litre tank (standing tank) including removal of old oil: 4,200 DKK ex. VAT	600 EUR
	Underground tank, removal of old oil, sealing of connections (no removal): 4,200 DKK ex. VAT	600 EUR
<b>Building envelope improvements</b>	Costs depend on the building standard etc. More information and tools to estimate costs can be found at e.g. <a href="http://www.byggeriogenergi.dk">http://www.byggeriogenergi.dk</a> (The Danish Centre for Energy Savings in Buildings).	
<b>Water based heat supply system in building</b>	Existing single-family house (150 m <sup>2</sup> ): Radiator system: 52,500 DKK ex. VAT	7,410 EUR
	New single-family house (180 m <sup>2</sup> ): Radiator system: 47,500 DKK ex. VAT	6,630 EUR
	Floor heating (in concrete slab): 37,000 DKK ex. VAT	5,190 EUR
	Floor heating (with diffusion plates): 47,500 DKK ex. VAT	6,630 EUR
	All prices include manifolds, piping, insulation, heat emitters/surfaces, thermostats and man hours.	
<b>Additional radiator surface</b>	2.2 DKK ex. VAT pr. Watt (standard radiators, 300-1,000 Watt)	
	Radiators installed including thermostats: Existing single-family house (150 m <sup>2</sup> ): 5,300 DKK ex. VAT	740 EUR
	New single-family house (180 m <sup>2</sup> ): 5,040 DKK ex. VAT	730 EUR
<b>Oil tank</b>	1,200 litre standing tank including installations: 8,500 DKK ex. VAT	1,210 EUR
<b>Flue</b>	Single-family houses: 5 meter stainless steel flue including fittings: 7,400 DKK ex. VAT	1,030 EUR
	5 meter vertical flue, balanced coaxial split installed in existing chimney: 4,200 DKK ex. VAT	600 EUR

**Table 2 Cost of accompanying investments**

### Operation and maintenance (O&M) costs

The fixed share of O&M (€/unit/year) includes all costs, which are independent of how the heating installation is operated, e.g. service agreements, chimney sweeping, spare parts and possibly insurance.

Any necessary reinvestments to keep the technology operating within the lifetime are also included, whereas reinvestments to extend the life beyond the lifetime are excluded. Reinvestments are discounted at 4 % annual discount rate in real terms. The cost of reinvestments to extend the lifetime of the technologies may be mentioned in a note if the data has been readily available.

Variable O&M costs (€/MWh) are seldom relevant for heating installations but include consumption of auxiliary materials (water, lubricants, fuel additives), treatment and disposal of residuals, spare parts and output related repair and maintenance (however not costs covered by guarantees and service contracts).

Planned and unplanned maintenance costs may fall under fixed costs (e.g., scheduled yearly maintenance works) or variable costs (e.g. works depending on actual operating time) and are split accordingly.

Fuel costs (including transportation costs and tariffs) are not included.

Auxiliary electricity consumption is included. The electricity price applied is specified in the notes for each technology, together with the share of O&M costs due to auxiliary consumption. This enables corrections from the users with own electricity price figures. The cost of auxiliary electricity consumption is calculated using the following electricity prices in €/MWh: 2020: 69, 2025: 85, 2030: 101, 2040: 109, 2050: 117. These prices include production costs and transport tariffs, but not any taxes or subsidies for renewable energy.

It should be noticed that O&M costs often develop over time. The stated O&M costs are therefore average costs during the entire lifetime.

Primarily relevant for stoking of biomass boilers, an estimation of how many hours of work a year for a household with a given heating installation is spend on maintaining and operating the installation.

Statistical data on O&M costs for heat technologies are often not available. Maintenance contracts proposed by leading installers and companies may in these cases provide a good source for estimating the O&M costs.

### Technology specific data

Additional data is specified in this section, depending on the technology.

## Definitions

### Building types and heat demand

Some of the heating technologies are described for different unit sizes and/or for existing and new buildings, respectively. This is shown in the table below. It should be noticed that some technologies, for example wood stoves, air to air electric heat pump and solar heating, do not offer a full heating solution providing both space heating and domestic hot water.

	Existing buildings		New buildings	
	Single-family houses	Apartment complex	Single-family houses	Apartment complex
<b>Oil boiler (including bio oil)</b>	X	X	X (bio oil)	X (bio oil)
<b>Gas boiler</b>	X	X	X	X
<b>District heating substation</b>	X	X	X	X
<b>Biomass boiler, automatic stoking</b>	X	X	X	X
<b>Biomass boiler, manual stoking</b>	X		X	
<b>Wood stove</b>	X		X	
<b>Electric heat pump, air to air</b>	X		X	
<b>Electric heat pump, air to water</b>	X	X	X	X
<b>Electric heat pump, brine to water</b>	X	X	X	X
<b>Electric ventilation heat pump</b>			X	X
<b>Hybrid heat pump</b>	X	X	X	X
<b>Solar heating system</b>	X	X	X	X
<b>Electric heating</b>			X	X

**Table 3 Technology descriptions - relevant combinations technology and building**

The catalogue considers existing and new single-family houses and apartment complexes. The size of buildings, the annual heat consumption and the peak-load demand is shown in the table below.

Since year 2020 is the base for the present status of the technologies, new buildings are supposed to comply with the current Danish building code, BR2018. Often the actual figures are higher as in the normative calculations. Hence, the peak load and energy demand of new buildings have been adjusted to reflect actual rather than theoretical use. The annual heating demand for new single-family houses is estimated at 65 kWh/m<sup>2</sup> and the annual heating demand for new apartment complexes is estimated at 55 kWh/m<sup>2</sup> based on information from SBI<sup>1</sup> [9],[12].

A new single-family house is defined to have an annual heat demand of 11.7 MWh inclusive of domestic hot water heating and a peak demand of 4.1 kW exclusive of domestic hot water. The peak load for domestic hot water in an individual house depends on whether or not the hot water is produced instantaneously or if it is

<sup>1</sup> This assessment is based on SBI 2016, "FORSKELLEN MELLEM MÅLT OG BEREGNET ENERGIFORBRUG TIL OPVARMNING AF PARCELHUSE" and dialog with SBI staff.

stored in an accumulator tank. This is a design issue and the preferred solution will depend on the characteristics of the specific heat supply technology, including its capital costs per kW of heat capacity. Instantaneous production of water for a single family house involves a max load of approx. 25-35 kW. If a storage tank is used, the max load is 2-7 kW dependent on the size and heating capacity of the tank<sup>2</sup>.

An average existing single-family house from before 1979 with average improvements and average extensions in floor area, is defined to have an annual heat demand of 18 MWh and a peak demand of 8.0 kW, exclusive of domestic hot water<sup>3</sup>.

An existing apartment complex is defined to have an annual heat demand of 900 MWh and a peak demand of 320 kW for room heating. The peak demand for domestic hot water is 70 – 115 kW for storage tank system inclusive of 15 kW pipe losses and 230 kW for instantaneous heating of domestic hot water by a heat exchanger without storage<sup>4</sup>.

Since 1980 there has been a gradual reduction of the specific energy consumption of buildings as a response to the strengthening of building codes.

A new apartment complex is defined to have an annual heat demand of 440 MWh and a peak demand of 160 kW for room heating. The peak demand for domestic hot water is 60 – 105 kW for storage tank system inclusive of 5 kW pipe losses and 220 kW for instantaneous heating of domestic hot water by a heat exchanger without storage.

Heating consumptions in this section is based on the average Danish weather for the period 2009-18 with in average 2650 Degree Days per year.

New single-family houses are expected to have an average size of 180 m<sup>2</sup>, whereas the average size of existing single-family houses is around 150 m<sup>2</sup>. An apartment complex is assumed to house 100 apartments.

	Existing buildings -1979		New buildings BR18	
	Single-family house	Apartment complex	Single-family house	Apartment complex
<b>Size</b>	150 m <sup>2</sup>	8,000 m <sup>2</sup>	180 m <sup>2</sup>	8,000 m <sup>2</sup>
<b>Peak load for space heat</b>	8.0 kW	320 kW	4.1 kW	160 kW
<b>Additional capacity for hot water</b>	4.0 kW	90 kW	4.0 kW	80 kW
<b>Annual heat demand incl. hot tap water</b>	18 MWh	900 MWh	11.7 MWh	440 MWh
<b>- hereof hot tap water</b>	3.0 MWh	280 MWh	2.7 MWh	200 MWh

**Table 4 Annual heat consumption and peak load**

The heating consumption for heating of domestic hot water to needed temperature is approximately 900 kWh/ann. per person in a household. To this pipe losses must be added. Hot water consumption is calculated from the number of people in a household and the type of residence they live in. Table 1.5 below presents the average number of inhabitants in single-family households and apartments respectively based on 2019 numbers.

<sup>2</sup> DS 439, Norm for vandinstallationer

<sup>3</sup> Data from SBi 2016:15 and SBi 2017:16

<sup>4</sup> SBi/BUILD based on data from HOFOR and FSB, DS439 og Videncenter for energibesparelse i bygninger, Energiløsning: Udskiftning af varmtvandsbeholder

Type of residence	Single-family houses	Apartments
Avg. number of inhabitants	2.5	1.8

**Table 5 Average no. of inhabitants in residences, source: Danmarks Statistik 2019**

Inclusive of pipe losses the annual heating consumption for domestic hot water is typically 15 kWh/m<sup>2</sup> in new single-family houses and 25 kWh/m<sup>2</sup> in new apartment complexes. In existing single-family houses, the annual heating consumption for domestic hot water inclusive of pipe losses is typically 20 kWh/m<sup>2</sup>. In existing apartment complexes with domestic hot water circulation, the annual heating consumption for DHW inclusive of pipe losses is typically 35 kWh/m<sup>2</sup>.

In the case of specific projects, the annual heat consumption and peak demand should be estimated more precisely, depending on the specific types of buildings and sizes.

In case a project is in need of technical and financial data for an installation with an installed capacity different from the standard sizes listed in table 1.4, an estimate can be found by interpolating technical data, while financial data can be found by interpolating the equipment costs and O&M costs. Installation cost are assumed to remain unchanged. As an example, data on the replacement of a 100 kW gas boiler in an existing apartment complex can be found by interpolating data between the 7.5 kW (existing single-family house) and the 160 kW boiler (new apartment complex), while using the installation (but not equipment) costs of the 400 kW (existing apartment complex).

## References

Numerous reference documents are mentioned in each of the technology sheets. Other references used in the Guideline are mentioned below:

1. Danish Energy Agency: "Forudsætninger for samfundsøkonomiske analyser på energiområdet" (Generic data to be used for socio-economic analyses in the energy sector), November 2019.
2. "Konvergensprogram Danmark 2015". Social- og Indenrigsministeriet. March 2015.
3. "Energy Technology Perspectives", International Energy Agency, 2012.
4. International Energy Agency. <https://www.iea.org/commentaries/understanding-the-world-energy-outlook-scenarios>. Accessed: 20/10/2020.
5. Construction Reliability, Safety, Variability and Sustainability, Edited by J. Baroth, F. Schoefs, D. Breyse, iSTE & WILEY, 2011, ISBN: 978-1-84821-230-5
6. SBi 2016:15. SMART ENERGI I HJEMMET EVALUERING AF FORSØG MED INTELLIGENT TEMPERATURREGULERING I ENFAMILIEHUSE
7. SBi 2017:16. VARMEBESPARELSE I EKSISTERENDE BYGNINGER
8. Videncenter for energibesparelse i bygninger, Energiløsning: Udskiftning af varmtvandsbeholder
9. SBi 2016, "FORSKELLEN MELLEM MÅLT OG BEREGNET ENERGIFORBRUG TIL OPVARMNING AF PARCELHUSE
10. DS 439, Norm for vandinstallationer
11. Energy labelling and ecodesign requirements for space and water heaters, European Commission, [https://ec.europa.eu/info/energy-climate-change-environment/standards-tools-and-labels/products-labelling-rules-and-requirements/energy-label-and-ecodesign/energy-efficient-products/space-and-water-heaters\\_en](https://ec.europa.eu/info/energy-climate-change-environment/standards-tools-and-labels/products-labelling-rules-and-requirements/energy-label-and-ecodesign/energy-efficient-products/space-and-water-heaters_en), last visited on 15.05.2020
12. SBI, 2020, conversation

## 201 Oil boiler (including bio oil)

### Contact information

Danish Energy Agency: Filip Gamborg, [fgb@ens.dk](mailto:fgb@ens.dk), Martin Rasmussen, [mra@ens.dk](mailto:mra@ens.dk)

Author: Original chapter from 2016 made by COWI. Update in 2021 by Ea Energy Analyses.

### Publication date

2016

### Amendments after publication date

---

Date	Ref.	Description
20-01-2021		Comprehensive update has been undertaken during Q4 of 2020. Primary focus is on data sheets, but text has been revised as well.

### Qualitative description

#### Brief technology description

Oil-fired boilers are made for hot water and steam production. In the following, only hot water boilers are considered. The boilers are made in a power range from 15 kW to several MW. The oil qualities considered are:

1. Domestic mineral fuel oil.
2. Domestic oil with added bio-oil up to 10 % (fatty acid methyl ester, FAME).
3. Raw bio-oil, e.g. rapeseed oil.
4. Hydro treated vegetable oil (HVO), [10].
5. Rapeseed oil Methyl Esther (RME)

The complete oil-fired system includes a boiler, a burner, an oil tank and a chimney or an exhaust system. In the case of a condensing boiler, a floor drain for the condensate should be available.



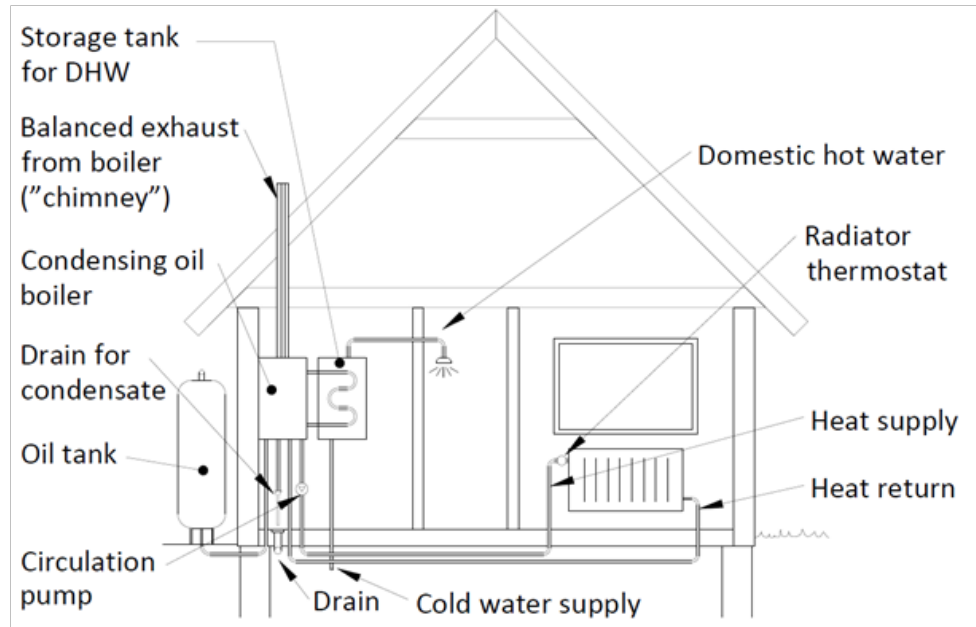

Figure 3 A typical installation of a condensing oil-fired boiler in a single-family house

The burner technology is atomisation by a high-pressure oil nozzle for minor boilers. For very large boilers, other technologies are available, for instance atomisation by a rotating cup. Some advanced recently developed small boilers are also using some rotating cup technology, which allows for modulating burner control. The burners may be yellow flame burners giving a small emission of soot or blue flame burners without soot emission but with a tendency to emit CO instead of soot. For the different fuels, the burner technologies are somewhat different - e.g., some fuels require preheating of the oil.

The boilers for all oil types are of almost similar design: a water-cooled combustion chamber and an integrated convection part. The materials are steel, cast iron or stainless steel. Modern boilers can be delivered with a corrosion resistant flue gas cooler that allows for condensation of the water vapor in the flue gas.

#### *Small domestic boilers (15-70 kW)*

The small boilers are used for domestic heating in single family houses. The 15kW boiler heats up to 200-300 m<sup>2</sup> of building area under Danish climate conditions. Very often, the boilers are built with an integrated hot water system, normally a tank of 80-150 l for the domestic tap water.

By Danish law it is not allowed to install oil boilers in new-builds. In existing buildings, oil boilers are not allowed if district heating or natural gas heating is an option. In new installations, use of condensing boiler technology is mandatory.

About 80,000 [9] oil boilers for domestic heating are installed in Denmark, the largest part in single-family houses in areas where natural gas or district heating are not available. The variation in the statistics reflect that many of the registered oil boilers are not used in practice or only used for supplementary heating. The number of oil-fired boilers has been declining steadily for several decades.

#### *Larger boilers (70 kW - 1 MW)*

These boilers are used in apartment complexes, institutions, workshops etc. If the connected heating system can deliver return temperatures below 45 °C, a condensing flue gas cooler will often be added. Units with integrated condensing flue gas cooler are also available. The efficiency is influenced by the flue gas temperature - in best cases only few degrees higher than the return temperature. In large boilers, the heat loss from the boiler can be reduced to only a fraction of a percent. Oil-fired boilers can have annual efficiencies around 100 %, if the return temperature from the heating system is sufficiently low, meaning lower than 48 °C, [1], [2], [3].

Most biooil-fired boilers are of this size. The main difference between a conventional boiler and a biooil boiler is a different burner, which is typically twice as expensive as a traditional burner. It is possible to convert from a conventional oil-fired system to a bio-oil system only by changing the burner and very few minor changes to storage tank and boiler. A different burner is needed as bio-oil does not have any lubrication effect and needs higher pressure to operate smoothly..

### Input

Domestic fuel oil is more or less the same as diesel. Bio oil (FAME) can be added up to approximately 10 % without severe problems.

Bio-oils can be used without blending with conventional mineral fuel-oil, but this requires a specific burner build for the purpose. Bio-oils are exempt from CO<sub>2</sub>-taxes.

### Output

Heat for central heating and for domestic hot water.

### Typical capacities

The heat output ranges from 15 kW to 1 MW.

### Regulation ability

The ability to reduce the heat output is excellent for most modern boilers. It should be emphasized that a boiler with a nominal heat output of 15 kW is able to operate at part load, many types will be able to operate down to almost zero heat output still obtaining a high efficiency. The reason for this is that the heat loss from the boiler typically is low because of insulation and low-temperature operation.

### Advantages/disadvantages

#### *Advantages*

The oil-fired boiler is a simple, reliable technology and operates with a high thermal efficiency. Also as stated above, the control ability of oil-fired burners is excellent.

Today, there are burners for pure bio-oil on the market, operating with acceptable levels of problems, although some enthusiasm may be required.

Normally regular service is made on oil-fired boiler-burner combinations. This is recommended by the authorities. The manufacturers normally recommend annual service.

#### *Disadvantages*

Due to external factors including, changing and unpredictable demands, geopolitics and potentially resource scarcity fuel oil prices are unpredictable and volatile, meaning that not only is the oil boiler a potentially expensive heat source, it is also difficult to predict the cost of heat one or two seasons ahead.

The reliability and the maintenance (regular cleaning of the burner as an example) of bio-oil burners cannot be compared with burners of mineral oil [10]. Some research and development is still needed in case of pure liquid bio fuels. The problems mostly concern practical issues with components (rubber gaskets), storage, sensibility to ambient temperature variations, preheating of the bio-oil, electricity consumption of the burner etc. Burners for raw bio-oil may also have difficulties when running on condensing boilers. Nonetheless these issues are considered to be solvable. Hydro treated vegetable oil (HVO) is almost pure hydrocarbon and can be burnt almost without emission of pollution. HVO is presently not on the market in Denmark.

For large plants - in MW size - burning of 100% bio-oil gives no problems. For domestic use, some problems still remain.

### Environment

A boiler fired with modern domestic fossil fuel oil with low content of sulphur and nitrogen will - except from the greenhouse gas CO<sub>2</sub> – give rise to the same level of pollution as a natural gas boiler. The pollutants in concern are:

- Unburnt hydrocarbon (only traces),
- CO (less than 100 ppm in the flue)
- NOX (less than 110 mg/kWh ~ 30 g/GJ)
- Soot (Soot number 0 – 1), see [8].
- Voluntarily most boilers are cleaned, adjusted and then inspected once a year for flue gas loss, soot and CO (for blue flame burners).

In Denmark, boilers with an input capacity larger than 100 kW must fulfil "Luftvejledning", [6], which includes "OML" (Danish abbreviation: Operationelle Meteorologiske Luftkvalitetsmodeller) calculation of immissions (The pollution concentration in the landscape around the plant).

### Research and development perspectives

The R&D in 60 years in combustion of mineral oil has resulted in very efficient, cheap and simple technology. Burner/boiler combinations with low emissions and efficiency close to the thermodynamic limits are common on the market.

The efficiency is regulated under the Eco design directive [12] that sets requirements for the minimum efficiency of products. The regulation for oil boilers entered into force in September 2015 and replaces the earlier demands concerning efficiency for boilers.

For boilers with a rated heat output between 70 kW and 400 kW the requirements are that efficiency (based on GCV, gross calorific value) shall be higher than 86% at 100% load and higher than 94% at 30% partial load. Based on lower calorific value this corresponds to 92 % respectively 100 %. This efficiency includes electricity consumption and some adjustment due to automatic control. ECO design demands correspond reasonably to former demands in the Building regulations - BR 10. [13] as with the assumptions in the tables.

### Examples of market standard technology

The best modern boilers operate with annual efficiencies in the range of 100 % (lower calorific value), dependent on the heating system to which the boiler is connected. At the same time, the boiler/burner can be chosen with very low emissions of pollution. Both HVO and RME are now available on the Danish market

[14][15][17]. Burning of these biooils require a different burner in the boiler, and this bio-oil burner is about twice as expensive as a conventional one.

Installation of a bio-oil fired boiler is exempt from the requirements of condensing boilers. Therefore, it is legal to install a new boiler with a bio-oil burner without the boilers being condensing. This will result in a lower efficiency.



Figure 4 Bosch olio Condens 8000F 19kW[16]    Figure 5 Kroll UB20 biooil burner [18]    Figure 6 Viessmann vitoradial 300T 101 to 545 kW[19]

### Prediction of performance and costs

Oil boilers are mature and commercial technology with a large deployment (a category 4 technology). Yet improvements are still possible and possible refinements of oil boilers are:

- Flue gas heat exchanger with exit temperature close to the return temperature from the heating system
- The connected heating system shall be able operate with return temperatures close to room temperature
- The connected hot tap water heat exchanger shall operate with return temperatures close to the cold tap water temperature.
- The boiler shall be placed inside the building so most of the heat loss from the boiler parts will be used in the building.
- The electricity consumption for burner, controls, preheating of oil etc. is to be minimized.

While the cost of oil boilers has decreased during the last 60 years, it is considered unlikely that this trend will continue with any significance – albeit smaller cost reductions are expected due to a general increase in productivity.

### Uncertainty

The expected development in thermal efficiency is assumed driven by increasing oil prices. If the expectations to the oil prices are not fulfilled, it is likely that the above-mentioned technological improvements will be delayed or not occur at all.

### Economy of scale effects

A typical price for 15-30 kW boiler of best quality cost in the range of 5,000-6,000 Euros, a 400 kW boiler cost in the range 30,000-35,000 Euros. So, the small ones cost around 275 Euros per kW and a 400 kW cost around 85 Euros per kW, hence oil boilers display a significant economy of scale effect.

### Additional remarks

## Quantitative description

See separate Excel file for Data sheets.

## References

- [1] Study "Eco-design of Boilers and Combi-boilers "<http://www.ecoboiler.org/>". 2006-2007 by Van Holsteijn en Kemna (VHK) for the European Commission, DG Transport and Energy (DG TREN).
- [2] RECENT PROGRESS (AND APPLICATION) ACHIEVED IN THE WAY TO ESTIMATE REAL PERFORMANCES OF DOMESTIC BOILERS ONCE INSTALLED Jean Schweitzer, Christian Holm Christiansen Danish Gas Technology Centre, Denmark Martin Koot Gastec, Holland Otto Paulsen DTI, Denmark. SAVE Workshop Utrecht 2000.
- [3] BOILSIM <http://www.boilsim.com/>
- [4] Sparolie.dk with a list of high efficiency oil-fired boilers and with a list of the status for existing oilfired boilers.
- [5] [http://www.blauer-engel.de/\\_downloads/publikationen/erfolgsbilanz/Erfolgsbilanz\\_Heiztechnologien.pdf](http://www.blauer-engel.de/_downloads/publikationen/erfolgsbilanz/Erfolgsbilanz_Heiztechnologien.pdf) (Rules for NO<sub>x</sub>). This is not present at the Blauer Engel Homepage, but can be found at the Internet.
- [6] Luftvejledningen fra Miljøstyrelsen. <http://www2.mst.dk/udgiv/publikationer/2001/87-7944-625-6/pdf/87-7944-625-6.pdf>.
- [7] Rapsolie til opvarmning, Teknik, økonomi og miljø. Videncentret for biomasse 2001.
- [8] Miljøstyrelsens vejledning nummer 3 1976. Gives a relation between soot number and soot concentration.
- [9] Estimated by the Danish Energy Agency, 2020
- [10] Paulsen, O.: Calculation of electricity consumption of small oil and gasfired boilers – based on Laboratory test data. Annex F in Schweitzer, Jean: SAVE report 2005: [http://www.boilerinfo.org/infosystem\\_el/webelproject/wp\\_reports/WP1.pdf](http://www.boilerinfo.org/infosystem_el/webelproject/wp_reports/WP1.pdf)
- [11] Commission regulation (EU) NO 813/2013, 2. August 2013.
- [12] Christiansen. C. H.: Ecodesignkrav for fyringsanlæg – input til BR2015, Notat til Energistyrelsen Teknologisk Institut dec. 2014.
- [13] Kedeffectiviteter for oliefyr og naturgaskedler i enfamiliehuse. DTU BYG, Teknologisk institut, Dansk Gasteknisk Center A/S, 2005
- [14] Cilaj Energi. 2020. <https://cilaj-energi.dk/om-bioolie/#.X5fcTlhKiUk>
- [15] OK. 2020. <https://www.ok.dk/erhverv/hjaelp/braendstof/hvo-biodiesel/kan-jeg-faa-hvo-biodiesel-leveret-af-ok>
- [16] Bosch. 2020. <https://www.bosch-thermotechnology.com/dk/da/ocs/privat/olio-condens-8000f-1098812-p/>
- [17] Cheminor. 2020. <http://cheminor.dk/>
- [18] Rapsoliefyr.dk. 2020. <https://www.rapsoliefyr.dk/index.php/produkter>
- [19] Viessmann. 2020. <https://www.viessmann.dk/da/beboelsesejendom/oliekedler/kondenserende-oliekedler/vitoradial-300t.html>
- [20] Study "Eco-design of Boilers and Combi-boilers "<http://www.ecoboiler.org/>". 2006-2007 by Van Holsteijn en Kemna (VHK) for the European Commission, DG Transport and Energy (DG TREN).

- [21] RECENT PROGRESS (AND APPLICATION) ACHIEVED IN THE WAY TO ESTIMATE REAL PERFORMANCES OF DOMESTIC BOILERS ONCE INSTALLED Jean Schweitzer, Christian Holm Christiansen Danish Gas Technology Centre, Denmark Martin Koot Gastec, Holland Otto Paulsen DTI, Denmark. SAVE Workshop Utrecht 2000.
- [22] BOILSIM <http://www.boilsim.com/>
- [23] Sparolie.dk with a list of high efficiency oil-fired boilers and with a list of the status for existing oilfired boilers.
- [24] [http://www.blauerengel.de/\\_downloads/publikationen/erfolgsbilanz/Erfolgsbilanz\\_Heiztechnologien.pdf](http://www.blauerengel.de/_downloads/publikationen/erfolgsbilanz/Erfolgsbilanz_Heiztechnologien.pdf) (Rules for NOX). This is not present at the Blauer Engel Homepage, but can be found at the Internet.
- [25] Luftvejledningen fra Miljøstyrelsen. <http://www2.mst.dk/udgiv/publikationer/2001/87-7944-625-6/pdf/87-7944-625-6.pdf>.
- [26] Rapsolie til opvarmning, Teknik, økonomi og miljø. Videncentret for biomasse 2001.
- [27] Miljøstyrelsens vejledning nummer 3 1976. Gives a relation between soot number and soot concentration.
- [28] Hvordan er landets boliger opvarmet og hvor ofte skiftes opvarmningsform? - Resultater fra en spørgeskemaundersøgelse. <https://ens.dk/sites/ens.dk/files/Statistik/opvarmningsundersoegelsen.pdf>
- [29] Aatola, H. et al.: Hydrotreated Vegetable Oil (HVO) as a Renewable Diesel Fuel: Trade-off between NOx, Particulate Emission, and Fuel. Consumption of a Heavy Duty Engine: [http://www.biofuelstp.eu/downloads/SAE\\_Study\\_Hydrotreated\\_Vegetable\\_Oil\\_HVO\\_as\\_a\\_Renewable\\_Diesel\\_Fuel.pdf](http://www.biofuelstp.eu/downloads/SAE_Study_Hydrotreated_Vegetable_Oil_HVO_as_a_Renewable_Diesel_Fuel.pdf), Helsinki University, 2008
- [30] Paulsen, O.: Calculation of electricity consumption of small oil and gasfired boilers – based on Laboratory test data. Annex F in Schweitzer, Jean: SAVE report 2005: [http://www.boilerinfo.org/infosystem\\_el/webelproject/wp\\_reports/WP1.pdf](http://www.boilerinfo.org/infosystem_el/webelproject/wp_reports/WP1.pdf).
- [31] Commission regulation (EU) NO 813/2013, 2. August 2013.
- [32] Christiansen. C. H.: Ecodesignkrav for fyringsanlæg – input til BR2015, Notat til Energistyrelsen Teknologisk Institut dec. 2014.
- [33] Kedelevititeter for oliefyr og naturgaskedler i enfamiliehuse. DTU BYG, Teknologisk institut, Dansk Gasteknisk Center A/S, 2005
- [34] Klimarådet 2020, Kendte veje og nye spor til 70 procents reduktion

## 202 Gas boiler

### Contact information

Danish Energy Agency: Filip Gamborg, [fgb@ens.dk](mailto:fgb@ens.dk), Martin Rasmussen, [mra@ens.dk](mailto:mra@ens.dk)

Author: Original chapter from 2016 made by COWI. Update in 2021 by Ea Energy Analyses.

### Publication date

2016

### Amendments after publication date

---

Date	Ref.	Description
20-01-2021		Comprehensive update has been undertaken during Q4 of 2020. Primary focus is on data sheets, but text has been revised as well.

### Qualitative description

#### Brief technology description

Gas boilers are burning gas (natural gas, biomethane etc.). The energy delivered by the combustion is used to heat water through a heat exchanger that is built into the boiler.

In a gas fired boiler, gas is burnt in a combustion section. It may be a traditional flame or a specially designed low-NOX burner. The heat is transferred to water through water cooled walls and through a water heat exchanger after the combustion section. Gas boilers can be wall hung or floor standing.

The hot water from the gas boiler is circulated in the radiators of the house (a pump is, therefore, required on the installation or in the boiler).

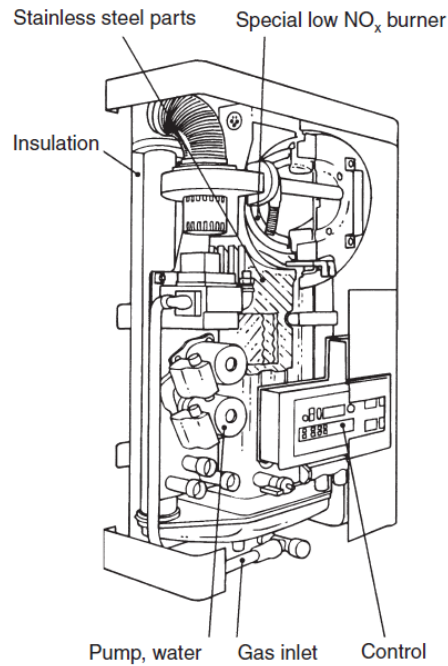

Figure 7 A wall hung gas boiler for a one-family house (Source: VarmeStåbi®, Nyt Teknisk Forlag)

A gas boiler is often called a "central heating (CH) boiler", as it is one of the elements of a central heating installation including boiler(s), a heat distribution system, heat emitters (radiators, convectors etc.) and a control system for the appliances.

### ***Condensing gas boiler***

A condensing boiler is a boiler designed for low-temperature operation including recovering low-temperature heat and the latent heat from water vapour produced during the combustion of the fuel. The condensing boilers include two stages of heat transfer, compared to traditional boilers (non-condensing boilers), which only include one stage. In the condensing boiler, a second heat exchanger is placed before the flue gas exit to collect the latent heat contained in the flue. Most gas-fired boilers also allow for condensation in the combustion chamber.



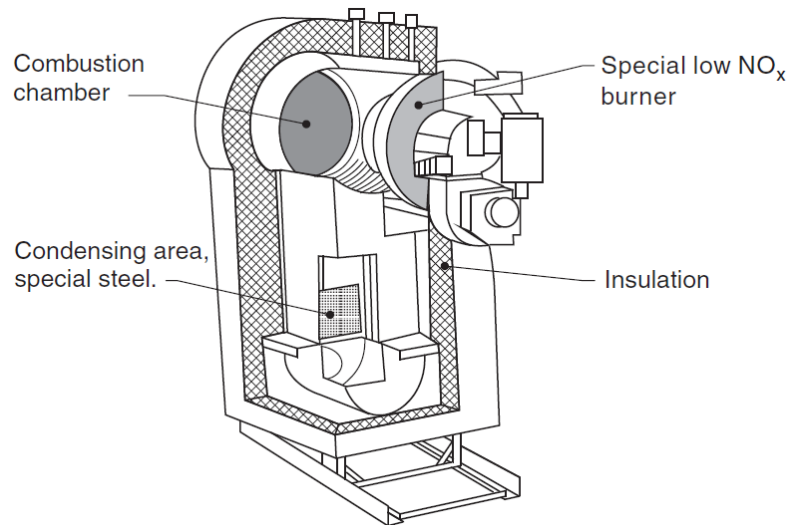

Figure 8: A floor standing medium size condensing gas boiler for apartment blocks etc. (Source: VarmeStåbi®, Nyt Teknisk Forlag)

Condensing flue gas recovery heat exchangers can also be installed as auxiliary equipment after the boiler. Traditional gas boilers (non-condensing boilers) can no longer be installed in houses/buildings (because of minimum levels of energy efficiency required in the ErP Directive [32] and the requirements of the Danish building regulations [22]). Most gas boilers will accommodate a large variety of natural gas compositions or LPG's with slight technical changes to the burner. New combustion control systems are increasingly used in new boilers allowing, without burner adjustment, burning of very large variation of gas quality. This ranges from low calorific value gasses to high calorific LPG gases, including biomethane [34]. Gas boilers are generally covering heating and domestic hot water production. For the later, hot water storage is mostly used (in Denmark). A minor market share is to appliances producing hot water instantaneously, the main advantage here is a lower space requirement.

### **Efficiency of gas boilers**

Gas boiler's energy efficiency is mainly depending on water temperature and load. The improved insulation of boilers and new burner technologies makes it possible to come close to the theoretically achievable efficiency. Annual energy efficiencies in real installations are today above 100% and up to 104% (based on lower calorific value) [9], [10]. This is also supported by recent field tests in Denmark [41]

As the water temperature and load has a great influence, the boiler heating efficiency will very much depend on installation including the heat distribution system and the right sizing of the boiler to cover the building heat demand. Furthermore, the user behaviour will also influence the efficiency. In general, the efficiency for hot water production is lower than the efficiency for heating. This means that user having high hot water demand may have lower seasonal efficiency.

Normally, the efficiency is rather stable throughout the boiler's life time. Statistics made on boiler servicing are showing rather constant flue gas losses between two services [38]

Annual energy efficiency referred to in the section "natural gas boilers" is calculated with BOILSIM a method developed with more than 15 EU partners [10], [11] and includes heating and hot water production based on Danish average houses.

### Input

Natural gas boilers are using natural gas as fuel. They can also use LPG gases (in general with minor burner changes). Biomethane (upgraded biogas where the CO<sub>2</sub> component has been removed) is increasingly being injected into the gas. In 2020, the average mix of biomethane in the Danish gas grid was approx. 20% and the share is predicted to increase in the future. Biomethane has a composition similar to natural gas and is fully compatible with boiler utilisation without any change on the appliance. It can be injected into the gas grid and mixed with natural gas or used directly. Raw biogas is not suited to injection in the grid, but can be used in specifically designed appliances

Hydrogen may also be injected into the gas grid and this is already done in several countries (mostly in Germany). New condensing boilers with premix burners can burn high % of hydrogen (60% or higher); however the long term impact of hydrogen is not very well known and other sensitive applications in the grid (engines, cookers, etc.) make scenarios with high concentration of hydrogen in the main grid unrealistic. It is generally admitted that a rate of 20 to 30% injection could be the norm in 10 to 20 years [34].

### Output

The form of energy generated by gas boilers is heat transferred to heated water. Thus, the output is hot water either used for heating or directly for domestic hot water.

### Typical capacities

For the domestic market, most of the gas boilers (single units) have a nominal heat output of about 20 kW and are modulating (see next section) down to 1 kW for very new technologies. Up to 20/35 kW are needed to cover the domestic hot water production (especially in the case of boilers without water tank) [24], whereas for heating 10 kW or less would be sufficient for most of the domestic houses [25]. There is no real differentiation between boilers for the new buildings compared to the existing buildings because most of the boilers are designed to cover the domestic hot water demand which is not depending on new or existing buildings. In general, gas boilers are produced as a series of similar appliances having different capacities. Examples of nominal capacities are 10, 20, 30 and 50 kW. For apartment blocks and other large buildings, where the heat demand is larger than for one-family houses, larger boilers of several hundred kW are used, but alternatively the combination of several domestic appliances connected in so-called "cascade" is a possible solution. In that case, the number of appliances in operation is determined by the heat demand.

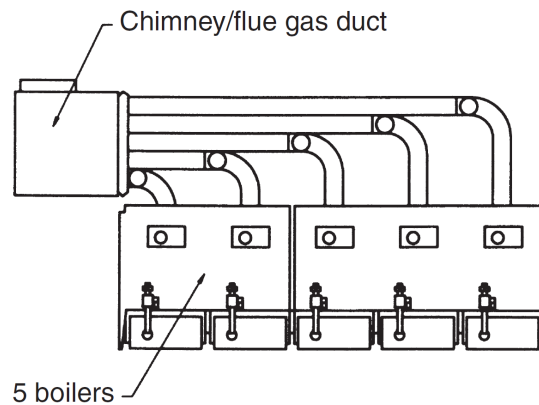

Figure 9 Cascade installation of boilers (Source: VarmeStåbi®, Nyt Teknisk Forlag)

### Regulation ability

Boilers are generally sold with controls that enable the optimal matching between the user demand and the appliance's heat production and the actual hot water demand. For example, in case the user needs hot water, the control system will give production priority to that demand. The control systems are able to communicate with components such as external temperature sensors or pumps. The control system will also adapt to other control elements such as radiator thermostat etc. Some control systems are auto-adaptive: they will learn from the recent past to optimize the control of the boiler. Most of the boilers on the present market are so-called "modulating" boilers. This feature allows the appliance to deliver reduced heat output without stopping the burner (the gas and air flows to the burner are reduced). Most of such boilers are able to modulate down to about 20% of the nominal maximum output. For example, for domestic boilers modulating ranges from 4 to 20 kW are typical, and technologies allowing very low minimum range are available (starting from 1 kW). The modulation feature reduces the too frequent start-stop of the boiler and improves the user's comfort and the lifetime of the appliance. Even boilers have controls systems, it is important to match well the boiler capacity with the building heat demand so to avoid for example frequent start stops.

### Advantages/disadvantages

#### Advantages

- Gas boilers offer an efficient way to use directly primary energy in homes and are designed to cover the entire heat and hot water demand of end users.
- CO<sub>2</sub> and NO<sub>x</sub> emissions of gas boilers are the lowest compared to any other fossil fuel boilers.
- The transport of natural gas to the buildings through the gas grid is less "energy costly" than the transport of oil.
- Because of the low investment costs and low gas prices, gas boilers are today one of the most cost-effective solution for the end-user [21].

#### Disadvantages

- The laying of the branch pipe requires extra construction work compared to other heating technologies especially in urban areas where pavements must be broken to establish the required infrastructure

### Environment

Gas boilers have low NO<sub>x</sub> emissions (lower than oil boilers, due to the nature of the fuel) [4] and low CO emissions. Gas boilers have a net emission of CO<sub>2</sub> if fuelled with fossil-based gas. With increasing injection of biomethane (about 20% in 2020) into the grid the carbon footprint of gas boilers is reducing.

About 60% of the CO<sub>2</sub>-emissions from a gas-boiler comes from the natural gas it uses during its lifetime, and 21% from extraction of the raw materials [33].

### Research and development perspectives

Gas boilers are mature and commercial technology with a large deployment (a category 4 technology according to the definition presented in the introduction). Today, gas condensing boilers have almost reached the highest possible energy efficiency and only a few per cent improvement is to be expected in the future. Still, improvements are possible to further decrease the electrical consumption and emissions. The electrical consumption has decreased due to the development of low-energy modulating pumps and labelling systems for gas boilers in Denmark [21]. NO<sub>x</sub> emissions have also been reduced with the introduction of the same label. Further improvements have been observed when the ErP requirements entered into force in 2018 [32].

Most progress, however, is foreseen in the field of combining gas boilers with other technologies in order to optimise the performances and to give more flexibility to adapt to the increasing production of versatile renewable energy. Hybrid systems are combining different technologies:

- Gas boilers can be used in combination with solar thermal energy. Gas solar boiler kits are available on the market.
- Gas boilers can also be used in combination with electrical heat pumps [17] and provide peak heating during periods with high heat demands and/or low external temperature. Such a setup increases the efficiency of the heat pump. Packages with electrical heat pumps and gas boilers are on the market already. Hybrid units can have good complementarity, which can achieve high system efficiency [18].

### Examples of market standard technology

A typical example of market standard technology would be a modulating, condensing boiler with a range of 2 to 18 kW. The efficiency is rather constant over the range of modulation, and NO<sub>x</sub> emission is low (low-NO<sub>x</sub> burner technology). Most of the condensing boilers on the market have now reached the highest achievable efficiency (with this technology) and can be considered to be best available technology.

It is predicted that gas-hybrid heat pumps will be more common in the future.



Figure 12: Bosch condens 5000 W, 2-28kW. [35]



Figure 10: Bosch condens 5000W CBR 100-3, 17-100kW. [36]

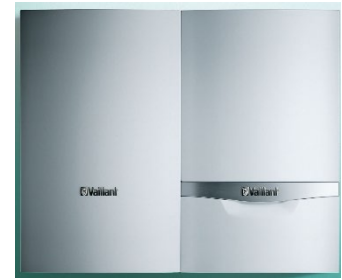

Figure 11: Valliant ECOTEC PLUS VC 156 5-5 with 75L hot water storage tank, 3-15KW.37]

### Predictions of performance and costs

Gas boilers have been used for several decades and are a mature and commercial technology with a large deployment (a category 4 technology). Further development in the area of individual gas boilers is mainly focusing on:

- Low-NO<sub>x</sub> burners
- Combustion controls enabling appliances to self-adapt to variations in gas composition
- Integration in smart grid [18]
- Conversion to hydrogen (pure H<sub>2</sub> boilers and boilers for H<sub>2</sub> natural gas blends)

A lot of research is also made to develop new technologies that might replace conventional gas boilers:

- The main developments are related to hybrid technology that should develop also in several EU countries [35]
- Gas heat pump has not yet penetrated the market, but there are interesting development toward low price gas heat pump for the domestic sector (USA) or very high efficiency heat pumps, 180% efficiency or more (France)
- Combined heat and power (including mini- and micro CHP and fuel cells) is still a niche market, but the mini-CHP market for commercial customers is in development.

While the cost of gas boilers has decreased, it is considered unlikely that this trend will continue with any significance – albeit smaller cost reductions are expected due to a general increase in productivity.

### Uncertainty

- **Heat efficiency, annual average, net (%)**: The uncertainty on the figures given in the table is rather low as the variation on Best Available Technology (BAT) boilers is quite small. The variations of annual efficiencies mostly depend on the way to use and install the boilers and especially the design of the

radiator system (low-temperature or traditional), but for the BAT installed in a new building, the radiator system will be a low-temperature system resulting in the highest energy efficiency.

- **Auxiliary Electricity consumption (kWh/year):** As domestic gas boilers have in general integrated pumps, the pump consumption is accounted in the tables of the data sheets. The uncertainty is larger, as the components and way to control them (after run time of pumps and ventilator) can be quite different.
- **NO<sub>x</sub> (g per GJ fuel):** Large variations are possible, but regulations are now limiting the emissions to a quite low level (Ecodesign).

#### Economy of scale effects

The price of boilers for small dwellings (<35 kW) is decoupled from the capacity of the boiler, instead the cost of small boilers depends on other features like material selection etc. In other words the cost of boilers is not directly proportional to the power (a 24 kW boiler is not twice as expensive as a 12 kW boiler) but in a series of boilers of the same construction, there will be an increasing of the price with the increase of the power. For the large boiler, there is a clear impact of the size on the price, and average values /8/ are indicating a more or less linear growth of 50 Euro/kW for boilers above 35 kW (but below 700 kW or less).

#### Additional remarks

Fossil-based natural gas boilers are generally only allowed in new buildings if the supply per 1.1.2013 is a dedicated "natural gas area" [22]. Gas boilers have a documented average lifetime of about 20 years [38], [39]

#### Quantitative description

See separate Excel file for Data sheets.

#### References

- [1] Annual efficiency calculation method for domestic boilers. SAVE Contract XVII/4.1031/93-008.
- [2] Gaskedlers naturlige overlevelse, Gasenergi nr. 5 2015,
- [3] Study "Eco-design of Boilers and Combi-boilers <http://www.ecoboiler.org/>. 2006-2007 by Van Holsteijn en Kemna (VHK) for the European Commission, DG Transport and Energy (DG TREN). Task 4 Section 3.1.
- [4] DGC project: Evaluation of the NO<sub>x</sub> emissions of the Danish population of gas boilers below 120 kW.
- [5] Start stop emissions of domestic appliances. H. Hüppelshäuser and F. Jansen. Ruhrgas. IGRC 1998.
- [6] HMN: <http://salg.naturgas.dk>
- [7] DGC project: Evaluation of the NO<sub>x</sub> emissions of the Danish population of gas boilers below 120 kW
- [8] Average cost information from Viessmann and Weishaupt.
- [9] RECENT PROGRESS (AND APPLICATION) ACHIEVED IN THE WAY TO ESTIMATE REAL PERFORMANCES OF DOMESTIC BOILERS ONCE INSTALLED Jean Schweitzer, Christian Holm Christiansen Danish Gas Technology Centre, Denmark Martin Koot Gastec, Holland, Otto Paulsen DTI, Denmark. SAVE Workshop Utrecht 2000.
- [10] Test of more than gas 100 boilers tested in laboratory at DGC. Application of BOILSIM model.
- [11] BOILSIM projects (EU work on models for boiler efficiency)
- [12] Annual efficiency calculation method for domestic boilers. SAVE Contract XVII/4.1031/93-008.

- [13] Framework for a European method to determine the energy consumption for domestic hot water production. SAVE Contract XVII/4.1031/Z/95-052.
- [14] Annual Efficiency: Pilot operation for the use of the harmonised method BOILSIM. SAVE Contract XVII/4.1031/Z/9674
- [15] Estimation of energy savings by replacement of fuel oil and gas boilers. SAVE Contract XVII/4.1031/D/97-072.
- [16] Energy consumption calculation method for domestic hot water and combined systems. SAVE Contract XVII/4.1031/Z/97-048
- [17] Example of hybrid technology: manufacturer: Gloworm; Product: Clearly Hybrid: <http://www.glow-wormheating.co.uk/clearly-hybrid/clearly-hybrid.php>
- [18] Paper IGRC 2014: Domestic gas hybrid technologies and their interaction with the Danish energy system, Author: Jean Schweitzer, Karsten V. Frederiksen, Danish Gas Technology Centre and Svend Vinter Pedersen, Emil Jacobsen, Danish Technological Institute.
- [19] God økonomi i boligopvarmning med naturgas, Henrik Iskov og Jan K. Jensen, DGC 2013
- [20] Bygningsreglementet: <http://www.bygningsreglementet.dk>
- [21] Labelling systems for gas boilers in Denmark: [www.dgc.dk/energimaerkede-kedler](http://www.dgc.dk/energimaerkede-kedler)
- [22] DS 439:2009 Norm for vandinstallationer
- [23] DS 469:2013 Norm for Varme- og køleanlæg i bygninger
- [24] Example of cost of a boiler: <http://www.billigvvs.dk/Varmesystemer-Gasfyr.html>
- [25] NGF Nature Energy 2014 Statistics on replacements of 226 boilers
- [26] Facts and figures about domestic gas boilers. Compilation of results covering 25 years of testing at DGC's laboratory. Report, January 2016. Jean Schweitzer, DGC
- [27] Drift- og vedligeholdelsesomkostninger for små gaskedler (villakedler), HMN GasNet, 2016
- [28] DGC Statistics, Efficiency and Emission test reports from district heating plants, up to and including 2014
- [29] Danish District Heating Association, information given to the 2012 survey for the report
- [30] Installation costs of new condensing gas boilers in NGF Nature Energys distribution area from 2012 - 2015, NGF Nature Energy (in Danish: Priser for installation af ny kondenserende gaskedel i Nature Energys distributionsområde i perioden 2012-2015)
- [31] Operation and maintenance costs of small gas boilers, HMN GasNet 2016 (in Danish: Drift- og vedligeholdelsesomkostninger for små gaskedler (villakedler)
- [32] Commission Delegated Regulation (EU) No 811, 812, 813, 814 /2013 with regard to the energy labelling & ecodesign requirements of space heaters and water heaters.
- [33] Life cycle assessment of domestic hot water systems: a comparative analysis. University of Brighton. 2014.
- [34] Personal communication with Jean Schweitzer, DGD, October 2020
- [35] Bosch. <https://www.bosch-thermotechnology.com/dk/da/ocs/privat/condens-5000-w-758023-p/> 2020.
- [36] Bosch. <https://vvsproffen.dk/shop/vvs-varme-gas-gaskedler-342124100-1366p.html> 2020
- [37] Vaillant. <https://www.vaillant.dk/professionelle/produkter/ecotec-plus-vc-156-5-5-h-246-5-5-h-31104.html> 2020
- [38] Facts and figures about domestic gas boilers. Compilation of results covering 25 years of testing at DGC's laboratory February 2016, updated 2017. Jean Schweitzer, DGC

- [39] Investigations on 25 gas boilers lifetime with HMN boiler statistics. 743-48 Jean Schweitzer, DGC Sept. 2016
- [40] Where is the gas heating market, and where is it going? Steven Ashurst, DeltaEE. EGATEC 2019 Conference, Groningen, the Netherlands
- [41] Dokumentation af villagaskedlers faktiske virkningsgrad, Kunderapport, DGC, November 2020, forfatter: Karsten V. Frederiksen/Mamadou Koné.



## 203 District heating substation

### Contact information

Danish Energy Agency: Filip Gamborg, [fgb@ens.dk](mailto:fgb@ens.dk), Martin Rasmussen, [mra@ens.dk](mailto:mra@ens.dk)

Author: Original chapter from 2016 made by COWI. Update in 2021 by Ea Energy Analyses.

### Publication date

2016

### Amendments after publication date

---

Date	Ref.	Description
20-01-2021		Comprehensive update has been undertaken during Q4 of 2020. Primary focus is on data sheets, but text has been revised as well.

## Qualitative description

### Brief technology description

District heating is a hydraulic system of pipes with the purpose of distributing thermal heat to end users of space heating and domestic hot water. The thermal heat comes from several sources, including heat from combined heat and power production (CHP), surplus heat from industry, and heat from waste incineration plants and boilers. More than 60% of Danish households are supplied with district heating by more than 400 district heating networks and in most major Danish cities, typically more than 95% of the end users are connected.

District heating units are categorised as either direct or indirect units. The district heating sub-station is placed at the end user with the purpose of making domestic hot water and delivering heat for the space heating system. Each building with a district heating sub-station is supplied from a branch pipe connecting the building to the overall distribution network. Figure 13 shows a sketch with typical components included in an indirect substation for single-family houses [1].

For comparison Figure 14 shows the design of a direct district heating unit. It is estimated that there is an even share of direct and indirect district heating units in Denmark. Additionally, Figure 15 shows the district heating substation installed in a single-family house.

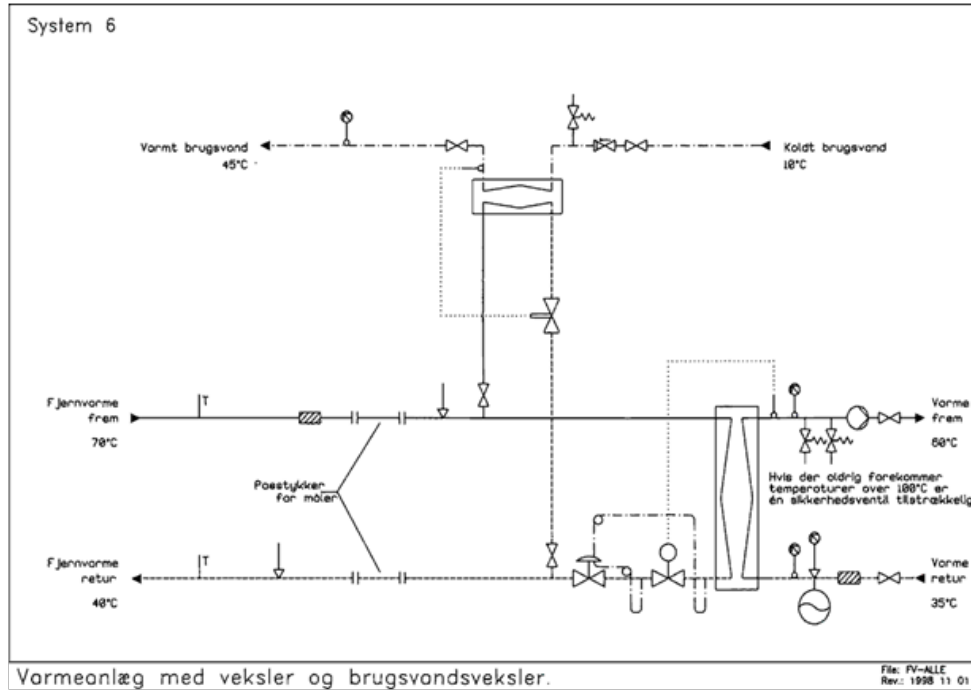

Figure 13 Indirect district heating substation with domestic hot water heater and heat exchanger for space heating in a one-family house. A branch pipe is connecting the building with the district heating network [1].

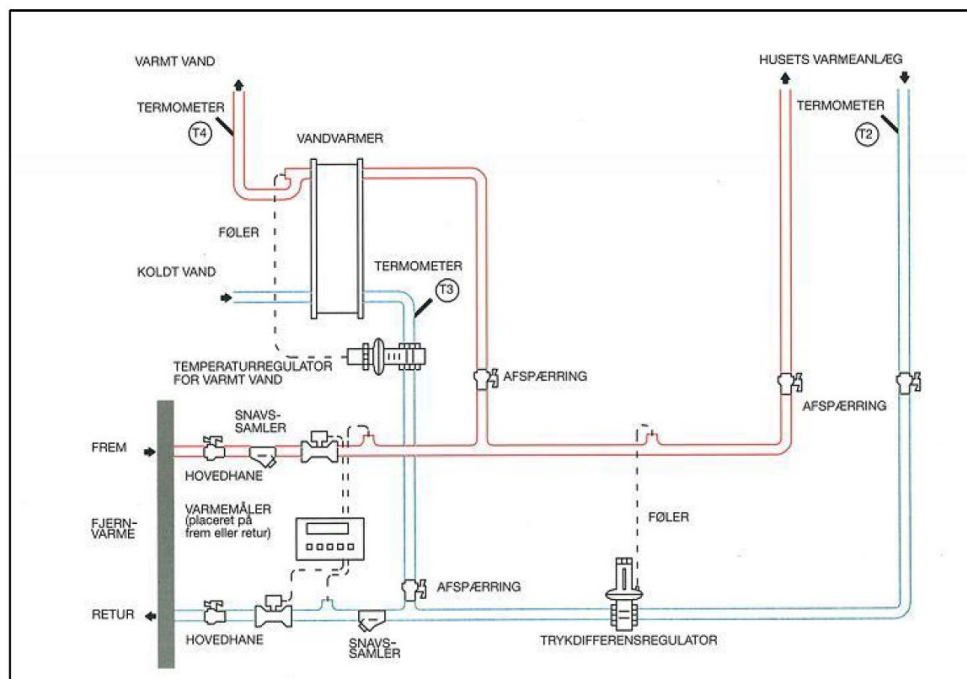
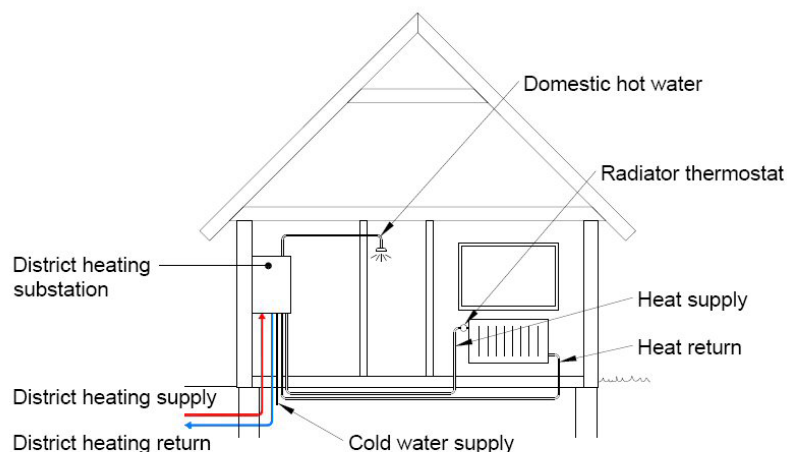

Figure 14: Direct district heating substation with domestic hot water heater and heat exchanger for space heating in a one-family house.



**Figure 15 District heating substation with domestic hot water heater and heat exchanger for space heating**

In apartment complexes, the standardized and prefabricated substation can be placed centrally, or small substations, the so-called flat stations, can be placed in each flat.

The substation is equipped with a domestic hot water heater based on either a storage tank with a heat exchanger embedded or a heat exchanger without storage, e.g. a plate heat exchanger. In some cases, a combination of an external heat exchanger and a storage tank is seen. The space heating is delivered by direct supply of district heating water or via a heat exchanger placed in between the district heating water (primary side) and the space heating water (secondary side). Further, the substation includes all valves, controllers, filters, pumps, etc. that are necessary for the operation. The substation also includes a heat energy meter. For substations constructed as units the unit is ready for convenient installation of the heat meter.

#### Input

Heat in the form of hot water supplied from the district heating pipeline.

#### Output

Heat (space heating and domestic hot water).

#### Typical capacities

The substation space heating capacity is dimensioned based on district heating temperatures and maximum allowable pressure drop. In single-family houses, the space heating capacity is typically in the range of 10 kW for district heating temperatures 70/40 °C and a maximal allowable pressure difference in the main pipes in the range of 0.3 bar. If the domestic hot water is prepared by an instantaneous water heater (normally including a plate heat exchanger) the heating demand for this is set to 33 kW for a single-family house. For large buildings, the capacities typically range from 70 kW to 250 kW for standardized wall-hung products. Above 250 kW, the substations will be individually designed and manufactured. The capacities of large buildings refer to district heating temperatures 70/40 °C in the following.

#### Regulation (control) ability

District heating substation can go from 0 – 100 % almost instantaneous.

On a component level, the design criteria include the ability to control domestic hot tap water temperature, flow temperature to the heating system, pressure loss and ability to maintain a low return temperature. The present building regulation in Denmark states that the flow temperature shall be controlled according to the outdoor temperature. Radiator thermostats shall be installed at all radiators in the building.

### Advantages/disadvantages

It is essential to realize that the district heating substation in itself cannot be compared to individual heating options like gas boilers or heat pumps. In order to make a whole techno-economic comparison, the whole district heating system must be taken into consideration, including distribution network and heat source. Hence the advantages and disadvantages considered in this chapter are compared to individual heating solutions.

#### *Advantages*

- Compact design - small installation space requirements
- Low maintenance costs
- Very low noise level
- No pollution produced locally.
- District heating allows for a high degree of security of supply and fuel flexibility.
- District heating makes utilization of surplus heat from industries and power production possible and allows for cheap and large-scale energy storages, which may contribute to integrate solar and power through flexible electricity consumption in heat pumps and electric boilers and flexible power generation from combined heat and power plants

#### *Disadvantages*

- The laying of branch pipes requires significant construction work compared to other heating technologies especially in urban areas where pavements must be broken to establish the required infrastructure
- Distribution network losses increase operation and maintenance costs
- Specific capital costs and distribution network losses of the district heating system increase with decreasing population density. This is a barrier which prevents district heating companies from providing district heating to customers in areas with low heat density.

### Environment

The environmental characteristics are dependent on the heat input to the specific district heating network. Therefore, no such characteristics are presented. Environmental declarations exist for specific district heating networks, e.g. the declaration of the Greater Copenhagen DH system.

### Research and development perspectives

Research and development are mainly taking place in the following areas:

- Plate heat exchanger design.
- Control strategies such as flexible district heating by HOFOR
- Low-temperature operation (< 55°C district heating flow temperature).
- Reduction of standby losses (primarily in new single-family houses).

- Integration or combination with other technologies (mainly outside Denmark). In Denmark, low temperature district heating combined with electric immersion heating elements or heat pumps for hot water production in some cases combined with smart grids are new research areas.

#### Examples of market standard technology

Low-temperature district heating substations have been demonstrated e.g. in the low-energy buildings of the housing association "Boligforeningen Ringgården". The substations incorporate efficient plate heat exchanger technology and are able to supply domestic hot tap water at 47 °C with a district heating supply temperature of 50 °C and return temperatures below 25 °C [3].

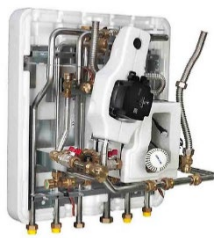

Figure 16: Metroterm 3 20kW direct DH unit [7]



Figure 17: Metroterm VXT Large direct DH unit 88-420kW [8]



Figure 18: Termix VVX indirect DH unit 4-22 kW [9]

#### Prediction of performance and costs

The substations have been used for several decades and are a mature and commercial technology with a large deployment (a category 4 technology). Some district heating utilities are working on decreasing the district heating supply temperature and have set new requirements for district heating substations [6]. In low-energy houses, low standby losses of technical installations are essential to comply with the Danish building code. Also new electronically controlled water heaters have entered the market and are expected to improve efficiency and comfort further [5]. While the cost of sub stations has decreased, it is considered unlikely that this trend will continue with any significance – albeit smaller cost reductions are expected due to a general increase in productivity.

#### Uncertainty

The technology is well established and it is likely that production cost for a district heating unit will decrease moderately in the future: improved and cheaper technology for producing heat exchangers, valves, electronics, new fitting and pipe systems will help this process.

#### Economy of scale effects

For the small unit in a single-family house, the price is in the range of 2700 Euros, equal to 150 Euros per kW. For a 400 kW unit the price is in the range of 16000 Euros equal to 40 Euros per kW.

### Additional remarks

Many district heating companies are implementing measures for consumers to utilize the heat in the district heating system better and thereby make it possible to supply a lower temperature and reduce the temperature difference between the two strings in the system. This will allow for a better business case for geothermal heating and heat pumps.[10]

### Quantitative description

See separate Excel file for Data sheets.

### References

- [1] Forslag til Forskrifter for godkendte standardunits, Teknologisk Institut, 2005.
- [2] Communication with Gemina Termix, [www.termix.dk](http://www.termix.dk).
- [3] Delrapport 2 - DEMONSTRATION AF LAVENERGIFJERNVARME TIL LAVENERGIBYGGERI I BOLIGFORENINGEN RINGGÅRDENS AFD. 34 I LYSTRUP. Energistyrelsen - EUDP 2008-II, 2011.
- [4] Communication with Danfoss Redan, [www.redan.danfoss.com](http://www.redan.danfoss.com).
- [5] [www.metrotherm.dk](http://www.metrotherm.dk).
- [6] Krav til fjernvarmeunits I VarmeTransmission Aarhus, December 2011.
- [7] Metroterm, MetroSystem 3 .  
<https://www.metrotherm.dk/produkter/fjernvarme/fjernvarmeunits/metro-system-3>, 2020
- [8] Metroterm, Metro VXT. <https://www.metrotherm.dk/produkter/fjernvarme/store-fjernvarmeunits/metro-vxt> 2020, 2020.
- [9] Termix, Termix VVX, <https://termix.dk/produkt/termix-vvx-med-tpv/>, 2020
- [10] Ener sparerrådets anbefalinger vedrørende lavtemperaturfjernvarme, Energisparerrådet, 2018.

## 204 Biomass boiler, automatic stoking

### Contact information

Danish Energy Agency: Filip Gamborg, [fgb@ens.dk](mailto:fgb@ens.dk), Martin Rasmussen, [mra@ens.dk](mailto:mra@ens.dk)

Author: Original chapter from 2016 made by COWI. Update in 2021 by Ea Energy Analyses.

### Publication date

2016

### Amendments after publication date

Date	Ref.	Description
20-01-2021		Comprehensive update has been undertaken during Q4 of 2020. Primary focus is on data sheets, but text has been revised as well.

## Qualitative description

### Brief technology description

The most common fuel used in small scale biomass boilers with automatic stoking is wood pellets. See Figure 19. However, some boilers, may be designed for firing of other types of biomass such as wood chips and grain.

The fuel is typically conveyed via an auger feeder from the fuel supply to the burner unit. In the burner, the combustion takes place during supply of primary and secondary air. The boiler is often a steel sheet boiler with a convection unit consisting of boiler tubes or plates.

Recent developments comprise smaller boilers that are able to modulate to very low load and thus are applicable in modern low energy housing as well as condensing boilers that are able to reach very high efficiencies while lowering the exhaust temperature below 100 degrees C.

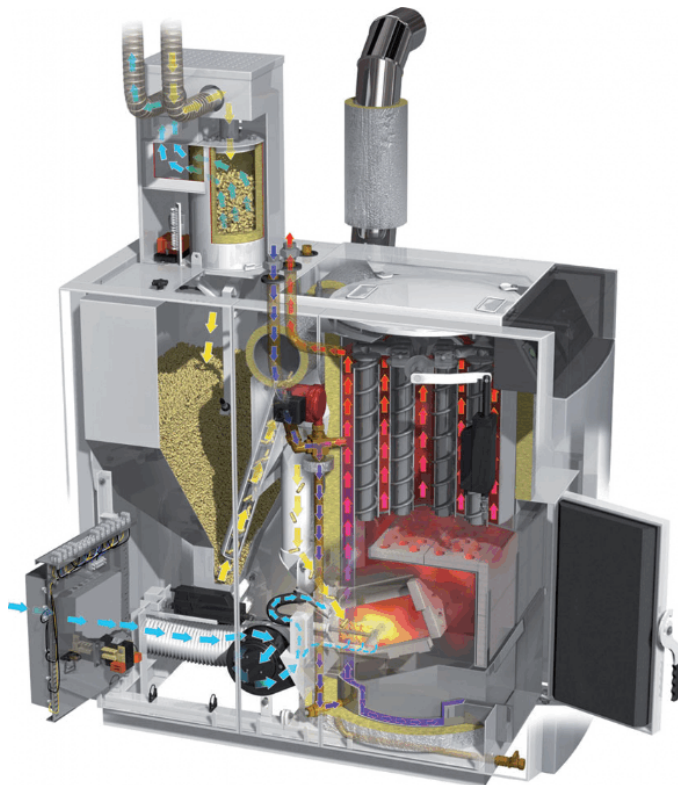

Figure 19 Biomass boiler, automatic stoking

Fuel can be supplied from an external earth storage tank, storage room or similar, or it can be supplied from an integral fuel hopper that is part of the boiler unit. Fuel is available in bags and can be added to the silo or hopper manually, or - in case of wood pellets - the fuel can be blown or tipped into the storage tank or room.

Within automatic biomass boilers, there are two plant types: compact plants consisting of a boiler and a burner in the same unit, and boilers with a detachable burner. Detachable burners can be approved up to 70 kW and are exclusively applicable for stoking with pellets.

Automatic biomass boilers can be a stand-alone solution, but a hybrid system like solar/biomass can be an attractive combination because biomass boilers are typically less suited for low-load operation than for example gas and oil boilers. In the summer period hot tap water is produced from the thermal solar heater, while the biomass boiler unit covers the heat demand for hot tap water and space heating during the rest of the year.

Some suppliers offer systems with advanced interfaces that allows for system control via a telephone app or online via an internet browser.

### Input

Wood pellets or wood chips. Another possible fuel depending on the boiler type is non-woody biomass such as grain. See additional remarks for detailed description of wood pellets.

### Output

Heat for space heating and hot tap water.

### Typical capacities

From 8 kW to 500 kW, or even larger, detachable pellet burners from 8 kW to 70 kW.

### Regulation ability

All boilers can be operated from less than 30% to 100% of full capacity, without violating emission requirements. The best models can be operated from 10 to 120% of the nominal heat output stated by the manufacturer in the boiler specifications.

### Advantages/disadvantages

#### *Advantages*

- The extra investment required for a new biomass boiler as opposed to an oil boiler is often limited if the existing oil boiler needed to be replaced anyway
- A biomass boiler is a means of decarbonizing residential heat supply
- Biomass for heating purposes is exempted from tax providing for competitive heating costs compared to fossil alternatives despite higher investment costs.

#### *Disadvantages*

- Biomass boilers take up more space than modern wall hung gas boilers and thus require an appropriate boiler room
- Dependent on the desired fuel storage capacity room space or an outdoor spot may be required if the storage is not placed underground



- For larger boilers, and in case of firing with other types of fuels (e.g. Straw or wood chips) than pellets, the labour needed for maintenance must be considered
- For small scale systems, some effort must be put into regular cleaning and ash removal by the owner and, if there is no large fuel storage included in the system, handling of the fuel. A modern boiler would require 5-10 h/y for ash removal [12]

### Environment

Use of high fuel quality and advanced technological combustion concepts ensure that automatic combustion systems are environmentally sound and efficient residential heating technologies. The legislative requirements have been tightened continuously and cover safety, efficiency, emission limits etc.

Secondary emission abatement systems such as electrostatic precipitators have been and are being developed and are coming closer to the market. In neighbouring countries, boiler investments are subsidised according to the application of secondary abatement systems. This technology might spread to Denmark where we will then see a decrease in emission levels from future boiler systems.

### Research and development perspectives

Biomass boilers with automated stoking are a technology undergoing continuous development, requiring R&D in the following areas:

- High-efficient and low-emission technologies
- Automation and comfort
- Fuel flexible boilers
- Improve system design of biomass heating systems
- Combined heat and power applications

### Examples of market standard technology



Figure 20: Efficient, integrated 12 kW pellet boiler from Rotec by KS Bioenergi [14]



Figure 21: Integrated 30 kW pellet boiler Phoenix from NBE A/S [15]



Figure 22: 250 kW pellet boiler for large buildings from LIN-KA [16]

Danish manufacturers of market standard technology can be found on web lists at [4]. The products on this list comply with the latest regulation of biomass boilers.

### Prediction of performance and costs

Biomass boilers with automatic stoking are in development and commercially available with a moderate deployment (a category 3 technology).

Price and performance of the technology is today well-known and only incremental improvements are expected. Therefore, the future price and performance projected is considered to be of fairly high certainty. Hence, technological improvements are expected to be realized without any significant increases in costs.

Use of biofuel boilers can be a relevant option for the approx. 500,000 households in Denmark found in rural areas or in areas without legal requirements of connecting to a district heating network or the natural gas grid. Biofuel boilers are common in Denmark and in the rest of Europe. In 2015, a survey showed that in around 100,000 households, an automatically fired biofuel boiler would be the primary heating device[13].

### Uncertainty

The cost of smaller units varies and depends on design, brand and options more than on the capacity of the boiler. In general, the prices of small units reflect the level of automation meaning the higher automation the higher the costs. Prices of larger-scale units also depend on the fuel flexibility e.g. whether the units only are able to convert wood pellets or also can handle wood chips etc.

As mentioned in the previous section only incremental improvements are expected and the future price and performance may be projected with fairly high certainty.

### Economy of scale effects

The costs vary also with other parameters than capacity. An example from one manufacturer: In small scale, e.g., from 10-50 kW, the unit price less than doubles. The reason is typically that different capacities come in the same physical size with only minor changes to key components. Above that, prices increase in steps.

### Additional remarks

Wood pellets are small, compressed pellets made of e.g., wood shavings and sanding dust compressed under high pressure and with none or a maximum of 1% binding agents. Wood pellets have typically a diameter of 6 mm or 8 mm and a moisture content of about 6-8 %. The length varies but is typically up to 5 times the diameter. Wood chips consist of wood pieces of 5-50 mm in the fibre direction, longer twigs (slivers), and a fine fraction (fines). There exist three types of wood chips: Fine, coarse, and extra coarse. The names refer to the size distribution only, and not to the quality.

### Quantitative description

See separate Excel file for Data sheets.

### References

- [1] Vurdering af brændekedlers partikelemission til luften i Danmark, Miljøprojekt nr. 6 2008, Kim Winther, Teknologisk Institut
- [2] Emissioner fra træfyrede brændeovne og -kedler, Miljøprojekt nr. 1324 2010, Johnny Iversen, Thomas Capral Henriksen og Simon Dreyer, Carl Bro.
- [3] Brændeovne og små kedler – partikelemissioner og reduktionstiltag, Miljøprojekt nr. 1164, 2007, Jytte Boll Illerup, DMU et al.
- [4] [www.teknologisk.dk/911](http://www.teknologisk.dk/911); Listen over godkendte biobrændselsanlæg

- [5] Strategic Research and Innovation Agenda for Renewable Heating & Cooling; RHC-Platform 2013; Renewable heating & Cooling; European Technology Platform.
- [6] Energibesparelser - det behøver ikke være så svært; Energibranchen.dk, nr. 3, september 2009.
- [7] Lot 15: Solid fuel small combustion installations-Base Case definition.
- [8] Konvertering fra olie og el til fast biobrændsel; 2012; Videncenter for Energibesparelser
- [9] Danish Emission Inventories for stationary combustion plants, inventories until 2011, Scientific Report from DCE n0. 102, 2014
- [10] [www.bios-bioenergy.at/en/electricity-from-biomass/](http://www.bios-bioenergy.at/en/electricity-from-biomass/)
- [11] Estimate by the Danish Energy Agency and Energinet, 2017
- [12] ProBiomass BV, conversation, 2020-10-26
- [13] Brændeforbrug i Danmark 2015 - Undersøgelse af brændeforbruget og antallet af brændeovne, pejse, masseovne og brændekedler i danske boliger og fritidshuse, [https://ens.dk/sites/ens.dk/files/Statistik/braende\\_2015.pdf](https://ens.dk/sites/ens.dk/files/Statistik/braende_2015.pdf) , Danish Energy Agency, 2016
- [14] Roteq, 12 kW pillefyr, <https://roteq.dk/>. 2020.
- [15] NBE A/S, pellet boiler Phoenix, <https://www.nbe.dk/rtb-phoenix-dk/>, 2020
- [16] Linka, 250 kW Boiler. <https://www.linka.dk/da/produkter/traepilleanlaeg-250---5000-kw/>, 2020

## 205 Biomass boiler manual stoking

### Contact information

Danish Energy Agency: Filip Gamborg, [fgb@ens.dk](mailto:fgb@ens.dk), Martin Rasmussen, [mra@ens.dk](mailto:mra@ens.dk)

Author: Original chapter from 2016 made by COWI. Update in 2021 by Ea Energy Analyses.

### Publication date

2016

### Amendments after publication date

Date	Ref.	Description
20-01-2021		Comprehensive update has been undertaken during Q4 of 2020. Primary focus is on data sheets, but text has been revised as well.

## Qualitative description

### Brief technology description

Modern manually fed boilers for combustion of wood logs typically have downwards draught or down-draught. The principle is that the fuel is heated, dried and gasified in the combustion chamber, after which the gases are led downwards (or down in case of down-draught) through a crevice in the bottom of the combustion chamber into the chamber where combustion takes place during supply of secondary air. This type of boiler is often provided with an air fan for supply of combustion air or a flue gas fan.

Recent developments include a much larger level of automation regarding start-up and operation of these boiler types. Many brands also provide hybrids including a pellet stoker ensuring flexibility and heat supply even when the manual feeding of wood logs is paused.

Older types of boilers are up-draught boilers and do not comply with the current environmental requirements. Manual boilers should be installed with an accumulation tank of appropriate size. A building's heat demand can be covered solely with a manual biomass boiler with a well-insulated accumulation tank.

### Input

The input is log wood of different sizes, depending on the boiler. For some boilers, also wood pellets.

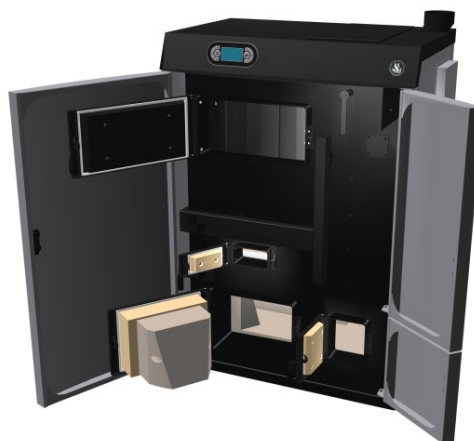

Figure 23: Double duty wood log boiler (manual stoking) prepared for mounting of pellet burner (automatic stoking)

### Output

Heat for space heating and hot tap water.

### Typical capacities

Log wood boilers are available from a few kW up to 100 kW.

### Regulation ability

The boilers are installed with a heat storage tank. Few log wood boilers have regulation abilities.

### Advantages/disadvantages

#### Advantages

- A biomass boiler with manual stoking is a simple and robust design
- It provides the opportunity for decarbonizing residential heat supply using local/proprietary resources.

#### Disadvantages

- Some effort must be put into regular cleaning and ash removal as well as feeding of the fuel. An estimate is 10 h/y for ash removal and cleaning and 50 h/y for fuel handling and feeding (avg. 10 min. per fire)
- 

### Environment

Examinations show that newer boilers with accumulation tank cause considerably less pollution compared to old up-draught boilers. The legislative requirements have been tightened continuously and cover safety, efficiency, emission limits etc.

### Research and development perspectives

Biomass boilers with manual stoking are a technology undergoing continuous development, requiring R&D in the following areas:

- High-efficient and low-emission technologies
- Automation

Figur 1

### Examples of market standard technology



Figure 24 Firewood boiler with advanced gasification/combustion concept S4 Turbo from Fröling [12]



Figure 25: 50 kW Solo Innova classic firewood boiler from Baxi [13]



Figure 26: Recent type 40 kW log wood boiler r counter current combustion, Vedex 4000 from Vølund Varmeteknik [14]

Danish manufacturers of market standard technology can be found on web lists at [4]. The products on this list comply with the latest regulation of biomass boilers.

#### Assumptions and perspectives for further development

Manually fired biomass boilers are common in Denmark as in the rest of Europe. In 2010, the population of manually fired boilers in Denmark was estimated to 48,000 [2]. In 2015, a survey showed that in around 31,000 households, a log wood boiler would be the primary heating device [12].

Costs and performance of the technology is today well-known and only incremental improvements are expected. Therefore, the future price and performance may also be projected with fairly high certainty. Biomass boilers with manual stoking are commercially available with a moderate deployment (a category 3 technology).

#### Uncertainty

Costs depend on designs and brands as well as the level of automation more than on the capacity.

#### Economy of scale effects

Biomass boilers with manual stoking are only produced within a very small range of capacity, hence the economy of scale is considered limited if applicable at all.

#### Additional remarks

### Quantitative description

See separate Excel file for Data sheets.

#### References

- [1] Vurdering af brændekedlers partikelemission til luften i Danmark, Miljøprojekt nr. 6 2008, Kim Winther, Teknologisk Institut
- [2] Emissioner fra træfyrede brændeovne og -kedler, Miljøprojekt nr. 1324 2010, Johnny Iversen, Thomas Capral Henriksen og Simon Dreyer, Carl Bro.
- [3] Brændeovne og små kedler – partikelemissioner og reduktionstiltag, Miljøprojekt nr. 1164, 2007, Jytte Boll Illerup, DMU et al.
- [4] [www.teknologisk.dk/911](http://www.teknologisk.dk/911); Listen over godkendte biobrændselsanlæg
- [5] Strategic Research and Innovation Agenda for Renewable Heating & Cooling; RHC-Platform 2013; Renewable heating & Cooling; European Technology Platform.
- [6] Energibesparelser - det behøver ikke være så svært; Energibranchen.dk, nr. 3, september 2009.
- [7] Lot 15: Solid fuel small combustion installations-Base Case definition.
- [8] Konvertering fra olie og el til fast biobrændsel; 2012; Videncenter for Energibesparelser
- [9] Danish Emission Inventories for stationary combustion plants, inventories until 2011, Scientific Report from DCE n0. 102, 2014
- [10] [www.bios-bioenergy.at/en/electricity-from-biomass/](http://www.bios-bioenergy.at/en/electricity-from-biomass/)
- [11] Estimate by the Danish Energy Agency and Energinet, 2017

- [12] Brændeforbrug i Danmark 2015 - Undersøgelse af brændeforbruget og antallet af brændeovne, pejse, masseovne og brændekedler i danske boliger og fritidshuse, [https://ens.dk/sites/ens.dk/files/Statistik/braende\\_2015.pdf](https://ens.dk/sites/ens.dk/files/Statistik/braende_2015.pdf) , Danish Energy Agency, 2016
- [13] Froling, <http://www.froling.dk/froeling-produkter/froeling-s4-turbo/s4-turbo/>, 2020
- [14] [HStarm](https://hstarm.dk) <https://hstarm.dk/produkter/biokedler/braendekedler/solo-innova/solo-innova-50-lc-mk2>, 2020
- [15] Nibe, <https://www.nibe.eu/assets/documents/20723/639699-1.pdf>, 2020

## 206 Wood stove

### Contact information

Danish Energy Agency: Filip Gamborg, [fgb@ens.dk](mailto:fgb@ens.dk), Martin Rasmussen, [mra@ens.dk](mailto:mra@ens.dk)

Author: Original chapter from 2016 made by COWI. Update in 2021 by Ea Energy Analyses.

### Publication date

2016

### Amendments after publication date

Date	Ref.	Description
20-01-2021		Comprehensive update has been undertaken during Q4 of 2020. Primary focus is on data sheets, but text has been revised as well.

## Qualitative description

### Brief technology description

A wood stove is an enclosed room heater used to heat the space in which the stove is situated. Usually, the wood stove is fired with a batch of 2-3 pieces of new firewood at a time. The refiring typically takes place when there are no more visible yellow flames from the previous basic fire bed, and when a suitable layer of embers has been created. Modern wood stoves have up to three air inlet systems in order to achieve the best possible combustion and to ensure that the glass pane in the front door does not get covered by soot: primary air up through the bottom of the combustion chamber, secondary air as air wash to keep the combustion alive and to maintain the glass clean, and tertiary air in the back of the combustion chamber for after-burning of gases. Some stoves need to have the air inlet dampers manually adjusted in connection with each new fired batch (maximum 3-5 minutes after each charge); others are more or less self-regulating.



Figure 27: Wood stove

The chimney serves as the motor of the stove and is essential to the functioning and performance of the stove. The chimney draught sucks air through the air dampers to the combustion chamber.

Heat from a wood stove is usually a supplement to other kinds of heat supply. The biannual firewood consumption survey from the Danish Energy Agency assesses the average wood consumption in stoves in Danish households. In 2015, the average consumption was 26 GJ [10].



Some stoves are fitted with an integrated boiler and can be connected to the central heating system and thus cover a larger percentage of the heat demand.

#### Input

Wood logs of different sorts like beech, birch and pine wood. The humidity should be of 12 to 20 %, and the size of the wood logs depends on the stove but usually about 250 to 330 mm with a weight of 700 to 1000 g.

#### Output

Space heating by convection and radiation. If the wood stove includes a water tank, it can also produce a certain amount of hot water to be used in radiators elsewhere in the house or to produce hot tap water.

#### Typical capacities

Typical capacities are 4 to 8 kW nominal output.

#### Regulation ability

By regulating the air dampers, the stove's heat output can be minimized or maximized within a few minutes, however, this can result in an increased emission.

#### Advantages/disadvantages

##### *Advantages*

- Wood stoves are usually independent of electricity supply
- Can supplement primary heating unit, which in turn can reduce the dependency of the primary heating supply.
- It provides the opportunity for decarbonizing a part of the residential heat supply using local resources. Some owners have the opportunity to gather firewood at low cost from their own premises at no costs apart from labour

##### *Disadvantages*

- Effort must be put into handling of the fuel wood and feeding the unit
- Potential effort to be put into gathering wood. As the stove is typically just a supplement, this work is often seen as a hobby more than a duty. Some argue that firewood provides heat three times: chopping, stacking, firing
- High level of local emission of air pollutants e.g., particulate matter. Potentially also immission of particles indoor due to operation of stove.

#### Environment

Woodstoves emit a high level of air pollutants e.g. particulate matter at local level.

Air pollution from wood stoves is dependent on series of factors such as stoking conduct, the individual stove design, the controlling of the combustion and the chimney in relation to the surrounding topography. The chimney is the engine for the combustion and where the draught is an essential part of how much air is reaching the combustion, this can be affected by the height of the chimney, and the surroundings e.g. other buildings, hills, forests as well as wind and wind direction. If the draught is not sufficient it will lead to poor combustion and higher emissions. A solution may be to install a draught stabiliser - a fan - that provides a stable draught and greatly improves the combustion while reducing emissions.

Different voluntary environmental labelling schemes of woodstoves exist e.g., the Nordic Swan-labelling. The Swan label emerged in 2005, is well accepted and can be seen as the consumer guarantee that the stove meets certain environmental requirements. Still, the emission from a modern wood stove is much higher than from e.g., gas, oil or biomass boilers.

R&D is going on nationally and internationally to improve the design of the combustion physiology as well as to develop secondary measures to abate emissions such as electrostatic filters. The latter are becoming standard in neighbouring markets [12].

In recent years, the Danish EPA has paid a premium to homeowners who have scrapped their old stoves and either closed their chimney or replaced the old stove with a new one. It is likely that Denmark will see new scrapping campaigns that will have the same purpose just with a focus on replacing younger stoves.

The European Eco Design Directive will enter into force for wood stoves in Denmark by 2023. The corresponding emission thresholds will be less strict than the previous regulation, Brændeovnsbekendtgørelsen [11].

#### Research and development perspectives

There is a continuous need for development of stoves with the purpose of reducing the particle emissions and design of stoves with lower capacity suited for low-energy houses. Please see above.

#### Examples of market standard technology

Some Danish manufacturers produce swan-labelled products, a list of which can be found at [4].

The swan label is a voluntary agreement, and labelled stoves must comply with relative stringent efficiency and emission requirements.



Figure 28: Morsø 6843 wood stove, swan-labelled. [7]



Figure 29: Lend wood stove with 8,7L water tank. 7-15kW. efficiency 80,27%. [8]



Figure 30. Hwam 30/55s insert with advanced control system [9]

#### Prediction of performance and costs

Wood stoves are commercially available with large deployment (a category 4 technology). Wood stoves are widely used in Denmark, and the number of installed stoves is around 800,000 [10]. Price and performance of the technology is today well-known, however, significant improvements with respect to emission performance are expected due to improved design of combustion chamber topology and combustion air supply control as well as draught stabilisation and secondary emission abatement measures such as an electrostatic filter. The societal attention as to emission of particles can be seen as a driver of this development. The technologies are closer to the market and are being implemented in neighbouring countries like Germany. Thus, it can be expected that the future performance will improve and - as a consequence - that the investment cost will increase.

#### Uncertainty

Prices vary very little with the capacity of the stove compared to the variation that is related to designs and brands. Price and performance of the technology is today well known it is however expected that from 2030 more automatic stoves will be marketed to overcome the legislation and future demands as mentioned above. Therefore, an increment in investment is expected. After this period, it is expected that the technology becomes generic and as a result of mass production investments are expected to drop somewhat again.

#### Economy of scale effects

Wood stoves are only produced within a very small range of capacities, hence it is not relevant to talk about economy of scale.

#### Additional remarks

Wood stoves without integrated boilers / heat storage will currently often be oversized for use in new low energy houses. However, they can be used for peak load and for heating up the building after the room temperature has been lowered e.g., during holidays. Units with lower capacity are being developed.

#### Quantitative description

See separate Excel file for Data sheets.

#### References

- [1] Brændeovne og små kedler – partikelemissioner og reduktionstiltag, Miljøprojekt nr. 1164, 2007, Jytte Boll Illerup, DMU et. al.

- [2] Emissioner fra træfyrede brændeovne og -kedler, Miljøprojekt nr. 1324 2010, Johnny Iversen, Thomas Capral Henriksen og Simon Dreyer, Carl Bro.
- [3] Lot 15: Solid fuel small combustion installations-Base Case definition.
- [4] Danish Emission Inventories for stationary combustion plants, inventories until 2011, Scientific Report from DCE n0. 102, 2014
- [5] <http://www.ecolabel.dk>
- [6] Estimate by the Danish Energy Agency and Energinet, 2017
- [7] Morsø, [https://pejsen.com/produkt/braendeovne/morsoe-braendeovne/morsoe-6843-braendemagasin/?gclid=Cj0KCQjwreT8BRDTARIsAJLI0KL5yvWUCZ99w83ZEKGyk4TIMB2fnVBipCtAYVvPTseTOtnCBKBjO1caAtuUEALw\\_wcB](https://pejsen.com/produkt/braendeovne/morsoe-braendeovne/morsoe-6843-braendemagasin/?gclid=Cj0KCQjwreT8BRDTARIsAJLI0KL5yvWUCZ99w83ZEKGyk4TIMB2fnVBipCtAYVvPTseTOtnCBKBjO1caAtuUEALw_wcB), 2020
- [8] Stendesign.dk. <https://www.sten-design.dk/shop/braendeovne-med-vandtank-145/lend-braendeovn-med-vandtank-7-15-kw-5-forskellige-farver/>. 2020
- [9] Hwam, <http://www.hwam.dk/hwam-i-30-55s.html>
- [10] Brændeforbrug i Danmark 2015 - Undersøgelse af brændeforbruget og antallet af brændeovne, pejse, masseovne og brændekedler i danske boliger og fritidshuse, [https://ens.dk/sites/ens.dk/files/Statistik/braende\\_2015.pdf](https://ens.dk/sites/ens.dk/files/Statistik/braende_2015.pdf), Danish Energy Agency, 2016
- [11] Teknologisk Institut, interview 2020-10-26
- [12] Workshop on residential heating, IEA Bioenergy Task 32 Biomass Combustion, January 22<sup>nd</sup> 2020, Graz, Austria, <http://task32.ieabioenergy.com/ieaevent/iea-workshop-residential-wood-combustion/>

## 207 Electric heat pumps, air-to-water, brine-to-water, air-to-air and ventilation

### Contact information

Danish Energy Agency: Filip Gamborg, [fgb@ens.dk](mailto:fgb@ens.dk), Martin Rasmussen, [mra@ens.dk](mailto:mra@ens.dk)

Author: Original chapter from 2016 made by Morten Hofmeister, PlanEnergi.

Update in 2021 by Anders Kofoed-Wiuff, [akw@eaea.dk](mailto:akw@eaea.dk), Camilla Lund, [cl@eaea.dk](mailto:cl@eaea.dk), Anders Rosenkjær Andersen, [aka@eaea.dk](mailto:aka@eaea.dk) from Ea Energianalyse

### Publication date

2020

### Amendments after publication date

Date	Ref.	Description
24-08-2022		Updated the chapter to more clearly convey the SCOP value
24-06-2021		Capacity of heat pumps have been revised to match heat capacity assessed at -7/55 °C
20-01-2021		Comprehensive update has been undertaken during Q4 of 2020. Data for low-price air-to-water heatpumps added.

## Qualitative description

### Brief technology description

Heat pumps are utilized for individual space heating, industrial processes, and district heat production.

Heat pumps employ the same technology as refrigerators, moving heat from a low-temperature level to a higher temperature level. They draw heat from a heat source (input heat) and convert the heat to a higher temperature (output heat) through a closed process. There are two main technology groups: compression heat pumps powered by electricity and absorption heat pumps powered by thermal energy from for example gas. In the Danish individual heating sector today, generally only electric compression heat pumps are utilised, thus this chapter will focus on the different types of compression heat pumps commonly installed in Denmark today. The different types of heat pumps differ mostly with regards to the medium from which they absorb heat from, for example ambient air or the ground, and deliver heat to.

The main advantage of heat pumps is their ability to provide more heat than electricity consumed. The energy flow is illustrated in the Sankey diagram in Figure 31. The heat delivered to the building is the sum of the heat absorbed from the environment and the electrical energy added. The heat pumps efficiency, also called "Coefficient Of Performance" (COP), can be calculated by the formula below.

$$COP = \frac{\text{Delivered heat}}{\text{Electricity consumed}} = \frac{6 \text{ kW}}{2 \text{ kW}} = 3$$

The COP denoted by the heat pump producer is often in the interval 3-5, meaning they deliver 3-5 times more heat energy than electricity consumed.

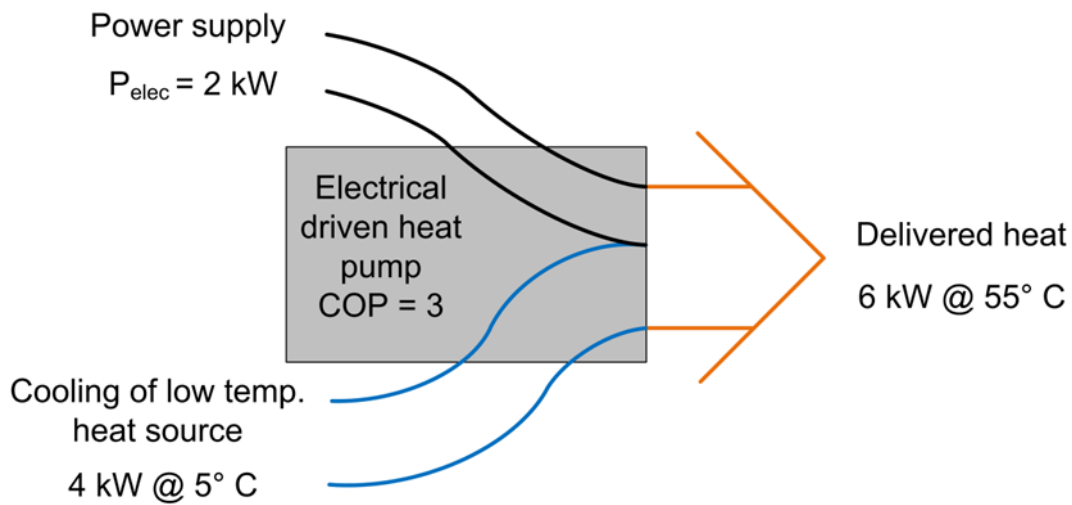

Figure 31 Sankey diagram for a heat pump.

The temperature difference between the temperature of the heat source and the temperature level of the heat delivered influences the COP. When the difference in temperature between the heat source and heat delivery decreases, the COP will increase and vice versa. This implies that the COP will vary according to the season – a low outdoor temperature implies a higher temperature difference, and a high outdoor temperature implies a low temperature difference. Likewise, the efficiency of a heat pump is also higher with lower delivered temperature, meaning a heat pump combined with floor-heating will generally have a higher efficiency compared to a heat pump combined with radiators.

The COP is the efficiency in certain predetermined operating conditions, but when considering the efficiency in an annual context, it is more correct to consider the *Seasonal Coefficient of Performance* (SCOP). The SCOP is calculated as defined in the European standard EN14825 [7] and expresses the weighted average annual efficiency. It takes the annual temperature variations and temporal correlation with the heat demand into account.

The following will present the main differences between different types of heat pumps.

Air-to-water heat pumps draw heat from ambient air using an outdoor unit, which is boosted by the heat pump and supplied as heat through a water-based heat distribution system (radiator, floor heating). Air-to-water heat pumps are also capable of providing the full demand of domestic hot water where newer heat pumps can deliver the necessary temperature without the use of direct electric heating in the water tank. This is due to technological development recent years allowing heat pumps to heat water to 55-65°C. The necessary temperature of hot domestic water is 55°C to eliminate bacterial growth such as Legionella in the tank. Figure 32 is an illustration of a typical heating system based on an air-to-water heat pump.

Newer heat pumps still include direct electric heating, to assist the heat production if needed. The air-to-water heat pump is generally dimensioned to cover 95-98 % of the total heat demand and the remaining

heat is provided by an electric water heater. This results in a more cost-effective solution while also providing security of supply in unusually cold periods or if the heat pump should suffer technical challenges. The electric water heater in a 7 kW heat pump defined at -7/55 degrees, typically has a capacity of 9 kW [10].

Air-to-water heat pumps can be split into two groups: monobloc and split units. In a monobloc unit all components related to the heat pump cycle are grouped inside a heat pump unit situated outside the home. This includes the compressor, the refrigerant, etc. Two pipes carry either water, or a mixture of water and antifreeze between the outdoor unit and the indoor unit. The indoor unit contains the hot water tank, expansion tank, and all components related to storing heat and interaction with the heating system.

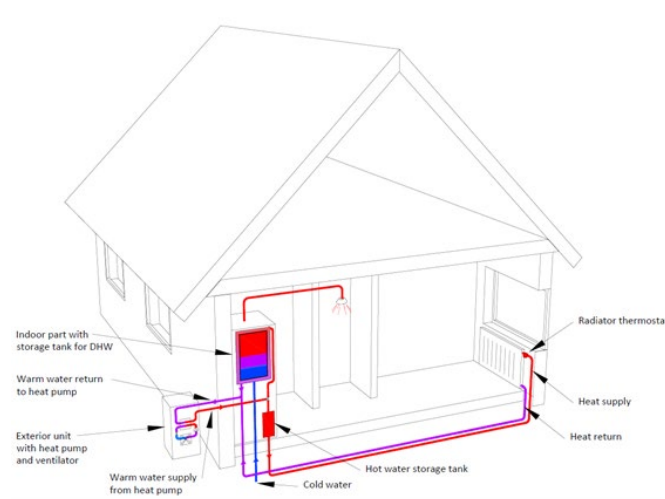

Figure 32 Illustration of a heating system based on an air-to-water heat pump (monobloc).

A split heat pump system consists of an outside unit, containing the heat exchanger, and an in-door unit, where refrigerant lines connect the outdoor unit and the indoor unit. In this type of system, the components related to the heat pump cycle are split between the indoor and outdoor unit.

The benefit of a monobloc configuration is that it comes with a fully charged refrigeration system, which means that there is no need to connect refrigerant lines and add refrigerant on site. The disadvantage is that the water in the outside piping and condenser presents a risk of freezing if the circulation should stop. This is unlikely though.

Generally, there has been more focus on improving the outdoor unit of a monobloc system, compared to split units, and therefore monobloc units typically generate less noise and are of higher quality.

Heat pumps are not normally dimensioned with sufficient heating capacity to instantaneously provide heat for domestic hot water. For that reason, a heat pump for a typical one-family house would be equipped with a roughly 200 litre water tank which is sufficient to supply four persons with hot water.

In some cases, an additional water tank, also called a buffer tank, is installed, to increase the volume of water to be heated and thereby limiting the number of start and stops of the heat pumps. Even though modern heat pumps are normally inverter-based and able to operate at 20-30 % of their nominal load there may be low load periods with many start-ups. Adding a buffer tank may improve the efficiency and diminish the wear

on the heat pump. The buffer tank would typically be dimensioned with a capacity of around 10 litres per kW of heat capacity. [8]

In Denmark, it is possible to acquire an air-to-water heat pump on subscription, where the consumer does not own the heat pump but instead pays per kWh of heat used. [19]

Air-to-water heat pumps also provide a relevant heating option for large buildings and building complexes. These solutions are typically more tailored to the specific needs of the building, and therefore less standardized. Some installers would design a heat pump solution for a large building as a cascade system based on several smaller single-house family size units. In such a system the cost of the outdoor units would be proportional to the cost of smaller sized systems, but the cost of the indoor unit and the water tank would be proportionally lower. An alternative to the cascade solution would be to deploy a single customized heat pump, but for smaller systems below around 400 kW this would often be more expensive.

Generally, there are comparatively fewer heat pump systems for larger buildings currently in operation, and they have not had the same growth and interest as the smaller systems for individual households. This could be due to the fact that large buildings are more often connected to district heating or natural gas or the fact that there are less suppliers able to offer and design such systems. As the market develops, the number of large buildings with heat pumps is also expected to increase, but it could also be argued that this segment may be more inclined to choose hybrid heat pump solutions (combining a heat pump solution with a gas boiler) in order to decrease investment costs and improve security of supply.

Brine-to-water heat pumps, often called ground-source heat pumps, absorb heat from the ground using a collector consisting of an underground hose/pipe circulating anti-freeze brine. The liquid absorbs heat from the ground which is boosted by the heat pump. The heat is delivered to the indoor unit which in turn is connected to the water-based heating system (radiators, floor heating, etc.) in the house.

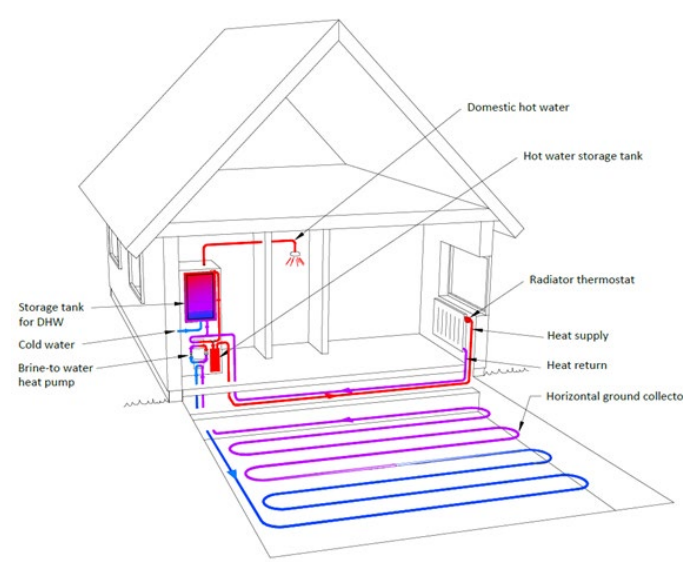

Figure 33 Illustration of a heating system based on a ground source heat pump (horizontal collector).



There are generally two types of collectors ground-source heat pumps can employ: 1) The horizontal collector and 2) the vertical collector, where the horizontal collector is most common and typically the least expensive option, but also requires more space.

The horizontal collector consists of tubing running horizontally at a frost-free depth, where the temperature is relatively stable throughout the year. The longer the collector, the more energy can be absorbed from the ground. For a typical house 2 m<sup>2</sup> of ground area is required per m<sup>2</sup> of living space [10], but generally never less than 400 m<sup>2</sup> for a household. For larger buildings, the required area can be substantial. An 8.000 m<sup>2</sup> apartment complex would by this standard require an area of 125 m by 125 m.

A vertical collector consists of holes drilled vertically deep into the ground and for that reason, it does not have the same space requirements and provides a relevant alternative in densely populated areas. A typical house will require a pair of vertically drilled holes with a depth of 120-160m. Generally, the vertical solution is more expensive than a horizontal collector because the drilling requires a specialist and a drilling rig. This type of collector is also largely affected by the geological properties of the ground. The approval procedure for a vertical collector systems is typically longer than for other heat pumps solution due to potential conflicts with drinking water abstraction.

Like air-to-water heat pumps, a ground source heat pump is capable of providing the annual demand of heat and domestic water, but usually the heat pump is dimensioned to provide 95-98% of the annual heat demand, where the heat output is boosted by an electric water heater during the coldest hours. This results in a more cost-effective system.

Ground-source heat pumps are also installed with a water tank, because like air-to-water heat pumps, they are generally not dimensioned with sufficient heat capacity to instantaneously provide the hot water during peak demand.

Ground-source heat pumps can also be used to provide the heat demand of larger buildings, including apartment complexes.

Air-to-air heat pumps draw heat from the ambient air, and supply heat locally through an air heat exchanger. Most air-to-air heat pumps have one outdoor unit and one indoor unit and are often referred to as "split-units". This configuration means that the heat pump can only supply heat at one location in the house and that larger coverage requires an air circulation system or that the doors to adjoining rooms are open.

Air-to-air heat pumps with more than one indoor heat exchanger (multi-split units) are also available, but the installation is generally more expensive and they are less common.



Figure 34 Illustration of a heating system based on a ventilation heat pump.

The amount of heat demand an air-to-air heat pumps can supply is highly dependent on its location in the building and the building design. For buildings with large rooms and good air circulation, the heat pump may be able to supply 60 % and 80 % of the space heating demand, but in most buildings the share of the total heat demand is reduced because separations within the building prevent circulation of the hot air. It is possible to install multiple indoor units at different locations in the building, which of course can increase the share of the heat demand which can be provided. Either way, it is not expected that an air-to-air heat pump can provide the full heat demand in a standard building, thus, requiring additional heating.

Air-to-air heat pumps cannot provide hot domestic water and therefore it is always necessary to have another technology installed for this. Hence air-to-air is usually installed as an auxiliary heating unit in combination with an existing primary source of heat, for example a boiler using biomass, gas or oil.

Many air-to-air heat pumps are reversible meaning that they can also be used for cooling (air-condition), and it is expected that a portion of installed units are acquired with the intention of primarily using them for air-conditioning.

Air-to-air heat pumps are very common in summer houses, where the main heat is provided by the heat pump and the domestic hot water is provided by an electric water heater. This is due to the fact that many summerhouses historically were built with electric heating, where the heat pump is a more economical solution which can also provide cooling.

Ventilation heat pumps, also called exhaust air heat pumps, draw energy from ventilation outlet air and heats up the air intake in the ventilation system. In theory, a ventilation heat pump can be either air-to-air, air-to-water or a combination of both, but the most common are air-to-water, where the heat is used to produce hot water for domestic use. These heat pumps therefore utilise heat that otherwise would have escaped the building.

The heat pump can heat the inlet air to a level providing more heat than the ventilation heat losses and can thereby compensate for the transmission loss to some extent. Depending on the ratio between transmission heat losses and ventilation heat losses, this type of heat pump might require a supplementary heat source to cover the heat demand all year around and to make individual room regulation possible.

There are also systems which can be installed in a bathroom, where there is excess heat. This type of system then takes heat from the air in the room and produces hot water but is not a standalone solution. This type of system is typically seen in summerhouses.

The data provided in this catalogue concerns only ventilation heat pumps used for production of domestic hot water.



**Figure 35 Illustration of a heating system based on a ventilation heat pump.**

#### **Input**

All heat pumps have electricity as an input.

air-to-water and air-to-air compression heat pumps have heat from the ambient air as an input,

ground-source heat pumps have heat absorbed from the ground as an input, and

ventilation heat pumps have excess heat from the building as an input.

#### **Output**

Air-to-water and ground-source heat pumps provide domestic hot water and water for heating.

Air-to-air heat pumps provide heated air for space heating.

Ventilation heat pumps usually provide domestic hot water and in some cases space heating as well.

#### **Typical capacities**

Air-to-water and ground-source heat pumps typically range from approximately 3-4 kW up to several hundred kW heating capacity, covering the needs for both space heating and domestic hot water in both low-energy buildings and other buildings. Water based heat pumps are normally designed to cover between 95 % and 98 % of the heat demand. The remaining demand would be covered by an electric heater, which is integrated in the indoor unit of the heat pump.

Typical heating capacities for a single air-to-air heat pump are 3-8 kW, which may cover between 60 % and 80 % of the space heating demand in a single-family house.

Ventilation heat pumps heating capacities range from 1.5 kW in single family houses to several hundred kW in large office buildings. In private households, the heating capacity is normally up to 3 kW.

### Regulation ability

All heat pumps have on/off regulation and many modern heat pumps are also equipped with capacity regulation, using electronically controlled expansion valves, meaning that the heat pump can balance the heat production to the demand continuously down to around 20-30 % of maximum capacity.

The efficiency and lifetime will decrease with increasing numbers of starts and stops and therefore the operation strategy of a heat pump over time has influence on the overall energy consumption and economy. Correct dimensioning and utilization of storage tanks is important to ensure the highest efficiencies. Heat pumps with capacity regulation are more dynamic and operation at partial load allows them to limit the number of starts and stops.

### Advantages/disadvantages

Heat pumps are much more energy efficient than traditional electrical heating and as power generation is increasingly based on renewable energy like wind and power solar power heat pump technologies also allow for a considerable reduction in primary energy consumption compared to boilers. Thus, integration of more heat pumps reduces Denmark's reliance on fossil fuels for heating and supports the shift towards electrification. A disadvantage of this is an increased strain on the local electric grid.

### Specific for air-to-water heat pumps:

Air-to-water heat pump can deliver the full heat demand of a building and can therefore directly replace any existing heating system with a water-based distribution system. According to experience among installation companies, it is only few buildings where a heat pump is not technically able to deliver the full heat demand, and in some buildings it may be necessary to make some changes to the heat distribution system, for example swapping older radiators to newer models.

Air-to-water heat pumps are easy to install compared to for example ground-source pumps and do not have large space requirements. The total time requirement for dimensioning and installing a heat pump is estimated at 32-40 hours. The actual installation typically takes 1.5-2 days with two workers in 2020.

The indoor unit is generally slightly larger than a standard cupboard (60 x 60 cm), meaning it can fit into most utility rooms in place of the previous heating installation, but this can also pose an issue in houses with limited space, especially if the house is converting from a gas boiler which is generally smaller. Furthermore, heat pump installations may require a buffer tank, further increasing the space requirement.

The outside unit of the air-to-water heat pump can generate some noise. The past 10 years, technological development has greatly reduced the generated noise for example by increasing the size of the fan and decreasing its speed. New units today generate noise in the range 52-67 dB, where the cheaper units generally produce more noise. 60 dB corresponds to a normal conversation while 50 dB corresponds to a quiet office. An increase of 6-10 dB is generally perceived as a doubling of the sound. Therefore, modern heat

pumps generally have a noise generation which will not bother most people. However, incorrect installation can greatly increase the noise generation, for example if the piping is under-dimensioned. An under-dimensioned heat pump will also be perceived as producing more noise because it will operate close to maximum load more frequently.

It should be noted that a heat pump generates most noise while de-icing, which is only necessary infrequently and only during the winter when people are mostly indoors. During warmer months, the heat pump only produces hot water for domestic use and is therefore much less active.

Air-to-water heat pumps are generally associated with a significantly higher investment than competing technologies, hereunder gas boilers, which can be a deterrent for some consumers, even though the annual cost is significantly lower. The ability to acquire a heat pump on subscription can appeal to consumers who cannot or do not want to pay the full investment cost of the heat pump.

Cheaper models are also making their way to the market, but they are generally associated with higher noise levels and probably shorter lifetimes.

The aesthetics of the outdoor unit can also be a deterrent for some consumers. The demand for better aesthetics is high and producers are starting to focus on the design of the unit.

Lack of competition for heat pumps for larger buildings can result in higher prices. This is caused by the fact that the systems for larger buildings are generally designed for the specific needs of the given building and there are few companies with these competencies today. The focus of the market has to a large degree been on heat pumps for smaller buildings, however interest in heat pumps for large buildings is expected to rise. Mass-production of larger heat pumps (>50 kW) holds a potential to lower prices of heat pump solutions in large buildings.

Especially for large existing buildings not born with an electrical heating system may not have sufficient ampere available for a heat pump installation. This is mainly due to the direct electrical heating which can require substantial ampere. Acquiring enough ampere can therefore increase the investment costs for some buildings. For these building it may turn out to be more economic to keep the original heat source, for example a gas boiler, and use this as backup instead of direct electrical heating [11].

### Specific for ground-source heat pumps:

Like air-to-water heat pumps, ground-source heat pumps can deliver the full heat demand of a building and can therefore directly replace any existing heating system with a water-based distribution system. The indoor unit is generally slightly larger than standard cupboard (60 x 60 cm) but some heat pump installations may require a buffer tank, further increasing the space requirement.

Ground-source heat pumps, unlike air-to-water heat pumps, do not have the same issue with noise, because the outdoor unit is replaced by underground pipes and/or hoses, which cannot be seen or heard. Instead, the ground-source heat pump has a disadvantage regarding space requirements. A horizontal collector requires a large enough property and that this area can be partially dug up under installation. The size of the collector depends on the specific conditions, but suppliers report that the length of the hose is typically double the area of the house, i.e. a 200 m<sup>2</sup> house requires a 400 m collector. [10] Newer and/or better

insulated buildings may need a smaller collector while older building may need a larger collector. The vertical collector requires less space but is more expensive and is more difficult to repair.

The ground source heat pumps access a more stable heat source, with a temperature above freezing, which means the COP is also more stable, and the annual average will generally be higher than that of an air-to-water heat pump.

Furthermore, the absence of freezing temperatures means the heat pump is exposed to less strain, which is reflected in the expected lifetime. Ground-source heat-pumps generally experience fewer problems over their lifetime, and suppliers have examples of systems from the 1980s still operating.

Ground-source heat pumps, like air-to-water heat pumps, are also a substantial investment. They are generally more expensive than air-to water heat pumps, but due to the absence of noise and potential for better performance, this can still be an attractive option in some buildings.

#### Specific for air-to-air heat pumps

Unlike air-to-water and ground-source heat pumps, air-to-air heat pumps have the disadvantage that they cannot provide the full heat demand and must be combined with another heating installation. The owner must therefore maintain and service both heating installations.

Like air-to-water heat pumps, air-to-air have an outdoor component, that some consumers might find unsightly. This outdoor unit can generate some noise, but the level is highly dependent on the specific product type and quality. Some people will also find the noise from the indoor unit due to the exchange of air by the fan uncomfortable.

The main reasons for the large number of installed air-to-air heat pumps are low investment costs, easy installation, and high efficiency. Air-to-air heat pumps do not require anything of the existing heating system and can be installed in both houses with electrical heating and a water-based distribution system. A drawback of the air-to-air heat pump is that, unless it is installed as a multi-split unit, it is only able to deliver heat in a single location of the house.

Since the air-to-air heat pumps deliver heated air at lower temperatures than the ground-source and air-to-water heat pumps, they generally have a higher SCOP.

#### Ventilation

The ventilation heat pump considered in this catalogue is only applicable in houses with a ventilation system. In old houses with uncontrolled ventilation due to air infiltration, this technology will not be suitable. In new and more airtight houses, ventilation systems are often applied meaning that ventilation heat pumps could be a suitable solution.

A disadvantage of ventilation heat pumps is that the heat capacity is limited by the heat that can be drawn from the exhaust air, and they can generally therefore not supply the full heat demand and must be combined with another heat source. This has the disadvantage that the owner must maintain and service both heating installations.

### Environment

The environmental impact of heat pumps relates mainly to power consumption, the potential of leaking of synthetic refrigerants and noise.

The environmental impact due to the use of electricity will depend on the way the electricity is produced and will not be discussed in detail.

Today almost all heat pumps for individual heating on the Danish market use synthetic refrigerants. These are known as HFC's (hydrofluorocarbons) which are fluorinated gases (F-gases), which possess a potent greenhouse effect and are covered by the Kyoto Protocol. There are many different refrigerants based on HFCs. In newer models of heat pumps sold today, R32 and R410A especially common.

The most common refrigerants based on HFCs have Global Warming Potentials (GWP) of about 1,500 to 4,000 compared to CO<sub>2</sub> which has a GWP of 1.

Danish Legislation bans the use of HFC's in heat pumps with more than 10 kg of refrigerant. Heat pumps for individual heating typically contain less than 2 kg's of refrigerant meaning that the ban does not affect this segment.

By law it is required that heat pumps with more than 1 kg of refrigerant are serviced. The service also ensures the heat pump is operating properly. Unfortunately, it is the experience of companies installing heat pumps that many heat pump owners do not ensure this. Some expect that up to 50% of air-to-water and ground-source heat pump owners do not perform the required annual service. [11] They also expect that this percentage is even higher for air-to-air heat pumps, but some of these heat pumps may contain less than 1 kg of coolant and therefore service is not required by law.

Currently, the requirement is an annual service, but in the follow-up agreement to the climate agreement of June 2020, it was decided to relax the requirement of the service, so that only a bi-annual service is required for heat pumps in private households. Systems for building complexes still must be serviced annually.

There are, some heat pumps model available with natural refrigerants such as CO<sub>2</sub> or propane (R290), but this is still a minority. It is expected that there will be a transition towards natural refrigerants or other less harmful refrigerants, but most models installed in Denmark today still use synthetic refrigerants. For example, the refrigerant R410, will be phased out during 2021 [12] and the European F-gas regulation from 2015 states that F-gases will be phased out towards 2030 and banned in many applications where less harmful alternatives are available, which will likely lead to an increased use of natural refrigerants in heat pumps.

R290 has a GWP of less than 1 and has the advantage that temperature of 75 degrees can be achieved. The refrigerant is also cheaper, however, the range of compressors is not that large yet. R290 cannot be used for units installed inside the home (split units) because it is flammable and explosive.

Due to the GWP of synthetic refrigerant leaks must be avoided. According to a report by the Ministry of Environment, the total refrigerant in heat pumps in Denmark corresponds to approximately 700,000 ton CO<sub>2</sub> of the which the report assumes there is an average annual leakage of 3% each year. [18] The risk of leakage is higher with split-unit systems, where the refrigeration cycle is assembled on-site as well as from older units.

In monobloc heat pump the refrigeration cycle is assembled during its production and connections are welded together and tested for leaks. Producers test monobloc systems for leaks and these will generally only leak if physically damaged. There is a risk of leakage when disassembling a heat pump system and the refrigerant should be discarded correctly.

Specific for air-source heat pumps:

Air-to-air and air-to-water heat pumps have an outdoor unit which generates some noise. The noise level is regulated by law and must be max 35 dB during night and max 45 dB during the day measured at the property boundary. Since most heat pumps generate more noise than this, they must generally be placed at some distance from the boundary. The amount of noise generated is correlated with the quality of the heat pump, where low-end heat pumps must be placed farther from property boundaries to adhere to regulations. Heat pumps with low noise can generally be placed within 3-4 meter of the property boundary.

Additionally, the EU ECO design regulation of heat pumps [16] includes specification of maximum noise from the heat pump itself. This is a focus of the industry and large improvements are expected.

Ground-source heat pumps do not generate noise.

**Research and development perspectives**

Compared to technologies such as gas and oil boilers there are historically relatively few heat pumps installed in Denmark and the installation skill and knowledge is therefore also lower than for gas and oil boilers. This can and does cause issues regarding correct installation.

Figure 36 shows the sale of different types of heat pumps since 2009. Air-to-water and air-to-air heat pumps have seen a dramatic increase in sales, and lack of education and experience can therefore especially affect these technologies.

Since about 2014, the annual sale of ground-source heat pumps has remained relatively stable around 2,100-2,300 annually sold units. Ground-source heat pumps have therefore not seen the same increase in sales as observed by air-to-water and air-to-air heat pumps, which in part can be attributed to the relatively higher costs, requirements for the collector and limited extra benefits. Ground-source heat pumps are more commonly installed in new buildings, where the required heat capacity is lower, and the installation is easier.



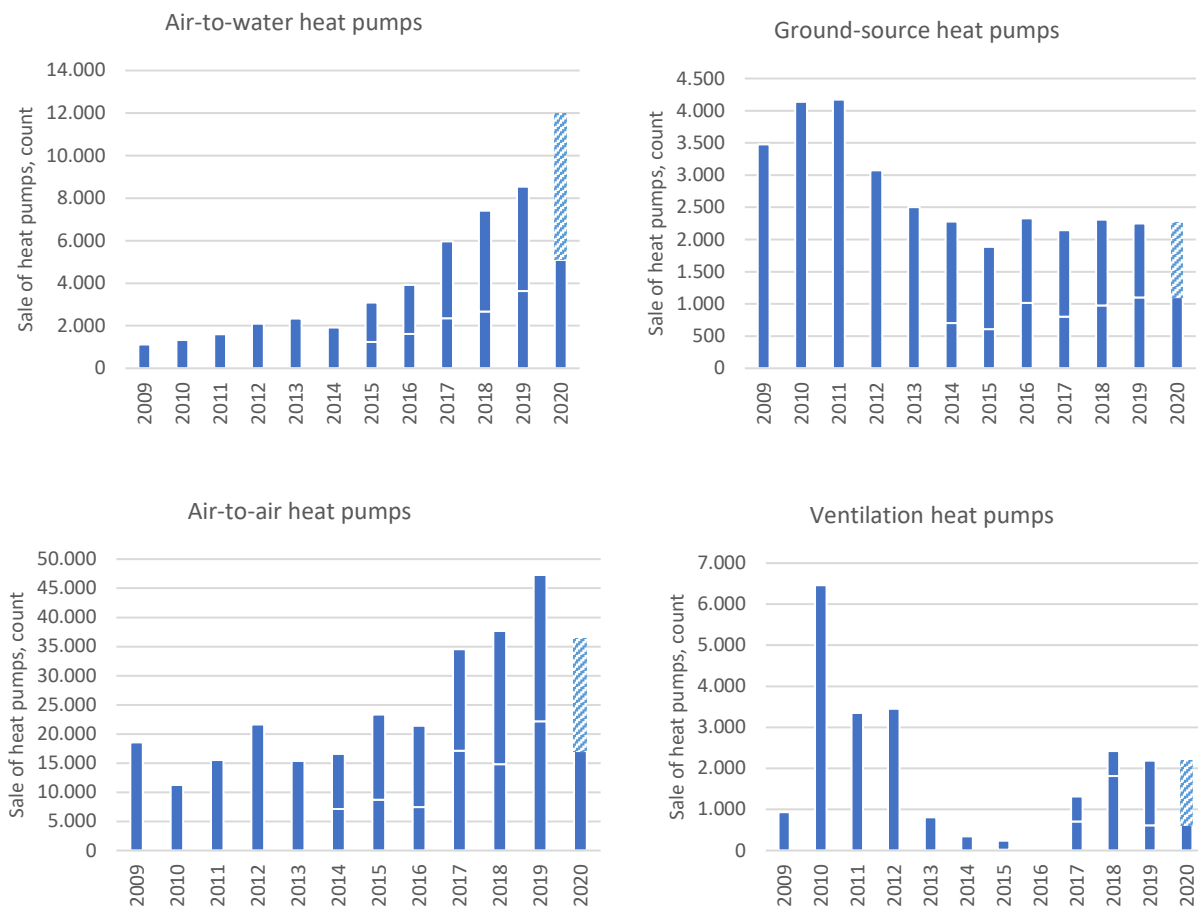

**Figure 36: Sale of heat pumps in Denmark. The split shows the biannual sale for 2015-2020. An estimate for the sale in the second half of 2020 is included, which is based on the share of the total 2019 sale registered in the second half of 2019. The sale of ventilation heat pumps includes both those capable of delivering heat to water and air. Source: Historic sale is published by The Danish Energy Agency [16].**

Incorrect installation results in reduced efficiency, increased noise, etc. For example, installing incorrectly dimensioned pipes, can drastically increase the noise, while errors in the physical installation or incorrect settings for the heat curve can lead to suboptimal operation and decreased efficiency. Heat pumps also need to be maintained properly for it to ensure continued, high performance. For example, gathering debris in the outdoor unit can increase the strain on the heat pump to maintain sufficient airflow.

It is unknown how many heat pumps currently are operating sub-optimally since the heat pump owners often do not have a way to know whether this is the case for their system. User errors, where users themselves tamper with the settings, can also decrease the performance and increase wear of the system. For example, when users feel cold their natural response is to increase the heat pumps delivered temperature, but the problem is not necessarily the water temperature but could be a suboptimal heat distribution system. Based on a Carnot-calculation it is estimated that increasing the delivered temperature by 1 degree, the performance decreases by approximately 3%-points.

An increased focus on education of those installing heat pumps, and in turn those operating them, is considered key to reduce the number of errors in installations and increase the number of heat pumps

operating optimally. It is important to note that the SCOP values presented in the data sheets reflect the situation with correct installation.

Achieving SCOP values over 5 is unlikely since this requires more expensive components which would dramatically increase the price. Since heat pumps already have higher investment costs than other heating installations, it is unlikely that the COP of future systems will be much larger than 5 [12].

Heat pumps are generally getting more sophisticated with regards to smart controls. This is not expected to be visible in the investment costs but can improve performance by automatically adapting the operation to the needs of the specific building, for example by communicating with intelligent radiator thermostats. Furthermore, remote access and surveillance is also expected to become more common. Newer models already have many of these smart functions.

Specific for air-to-water heat pumps:

Today, the time required for the actual installation of an air-to-water heat pump in households is generally 20- 30 man-hours, not including the time required for dimensioning, transport, etc. Historically it has taken longer, but producers have made their models easier to install also to decrease the likelihood of errors. Currently models are generally fabricated with predefined location of the in- and outlets (either top or bottom). This can complicate installations, but the next generation of models are expected to offer both placements of the out-/inlets. Furthermore, increased experience and education has contributed to decreased installation time.

Generally, noise generation is a top priority when developing future heat pumps. In an interview with Bosch it was mentioned that producers of heat pumps are focusing heavily on reducing noise generated from their units, because countries like the UK and Holland are requiring installed heat pumps to live up to strict noise regulations. They therefore expect that heat pumps will only produce 48 dB at maximum load within 5 years and only 43-45 dB within 10 years. In Denmark, this means that these heat pump can be placed 2-3 meters from the property boundary before 2025 and 1-2 meters from the boundary before 2030 [12]. Interviews with other suppliers confirm that noise generation is a key focus [11].

Currently air-to-water heat pumps for larger buildings are to a large degree custom solution whereas heat pumps for households are standard products. Furthermore, air-to-water heat pump systems for larger buildings is still not common, but interest in this segment is growing. This means there may be a larger potential for price reductions as solutions become more common and standardized.

Today's air-to-water heat pumps can reach temperatures of 65 °C where it previously was only possible to reach 45 or 55 °C. In the near future, the use of propane as a refrigerant can potentially increase temperatures to 75 degrees. Generally, developments within the use of refrigerants are expected, where a shift from the use of F-gases to natural refrigerants is expected.

There are developments regarding the physical size and design of the heat pumps, where producers are making the units smaller and more aesthetically pleasing, as this factor can affect consumers likelihood of choosing a heat pump.

Specific for ground-source heat pumps:

Ground-source heat pumps have been utilised for heating for a longer period and therefore the same degree of development is not expected. As with air-to-water heat pumps, ground-source heat pumps are expected to be able to deliver temperature up to 75 degrees and convert to natural refrigerants in the future.

Specific for air-to-air heat pumps:

Air-to-air heat pumps are a mature technology and therefore major technological developments are not expected. As air-to-water heat pumps there may be developments regarding noise and the physical appearance.

Specific for ventilation heat pumps:

The focus on ventilation heat pumps is less than that of the other types of heat pumps and the segment of buildings where they are relevant is smaller. According to the Danish Energy Agency's heat pump sale statistics, only about 2,000 or less of these types of heat pumps have been sold annually recent years.<sup>5</sup>

---

<sup>5</sup> Includes all for types of ventilation heat pumps in the statistics.

Examples of market standard technology



Figure 37: Metrotherm, Metroair I, 16kW heat. Outside unit. Split unit. [1]



Figure 38: Bosch compress 7000i, Air-Water Outside-Unit on the left, inside unit on the right. 7kW split unit. [2]



Figure 39: Compax Brine-Water indoor-unit. 10kW. SCOP 4,61-5,2. [3]



Figure 40: Bosch compress 6000 LW 6kW [4]



Figure 41: Nilan Compact P series ventilation heat pump can be combined with brine-water or air-water unit. 3-9kW [5]



Figure 42: Panasonic CZ25TKE air-air heat pump. 5,2kW. R32 refrigerant. [6]

Prediction of performance and costs

Specific for air-to-water heat pumps:

Air-to-water heat pumps can be categorized between category 3 and 4. For the installation and operation there is a potential for improvement. The time required for an installation is expected to decrease while the quality of the installation is expected to increase.

The installation cost is expected to decrease as education and experience in the industry increases. One source expected to see a decrease in the time required for the actual installation a heat pump to one workday for two people or approximately 14 hours where an installation today takes 1.5-2 workdays with 2 people. This corresponds to a reduction of man-hours by 33-50%. Another source expects a total decrease in price of 20-25% within the next 10 years, where 5-10% stems from reductions in the equipment price [14]. Some sources expect little or no development. This simply shows that, the price developments are very uncertain, and this uncertainty can partly be attributed to the fact that the main development in sales of air-to-water

heat pumps has been in the last 5 years. This short time-frame means that the tendencies are not very clear yet, but it is quite certain that sales and competition will continue to rise, and therefore the total average price will decrease.

Due to the fact that air-to-water heat pumps is a growing sector, cheaper products have only recently begun to enter the market with significant volume. Sources report mixed reactions regarding these cheaper products, where some suppliers report that they do not wish to install them for fear that they fail too quickly or underperform, while other suppliers have not found this to be an issue. Generally, these cheaper products are expected to have shorter lifespans, higher noise generation and lower efficiencies, but also lower investment costs. Suppliers have experience that these more often require reparations. The typical air-to-water heat pump sold in 2020 for a standard existing house in Denmark costs approximately 11,000 euros excl. taxes and is expected to be a mid- to high-end product, where low-price heat pumps can reduce this cost by 20-30%. Because the future of the cheaper models is still uncertain and since it is expected that they perform differently compared to the average heat pump sold today, they have their own datasheet for existing households. A considerable number of cheaper models are not expected to be installed in the other building segments

Overall, the equipment price-component of air-to-water heat pumps in the mid to high-range is expected to decrease relatively less than the installation costs. This is largely due to the sheer amount of material they contain. Of course, the price of individual components will decrease, but a heat pump is more complex machine compared to a gas or oil furnace, and therefore the price decrease may not be as dramatic as seen by gas furnaces. It is expected that most heat pumps sold in Denmark today are mid to high-range products. Instead, the largest relative decrease in price is expected in the installation.

The price developments are based primarily on discussions with suppliers, but the level is validated by a learning curve calculation while keeping in mind historical price developments for heat pumps and other technologies.

For existing single-family houses, it is assumed that the equipment will decrease by 10% by 2030 while the installation will decrease by 25%. This corresponds to a total investment cost reduction of 14%. These expectations are applied to both the mid- to high-range heat pumps and the cheaper models.

For new households, the equipment investment is also expected to decrease by 10% toward 2030 and again between 2030 and 2050. A smaller reduction of the installation costs is expected, because this is already optimised compared to installing heat pumps in existing buildings to a larger degree. A decrease of 15% of the installation cost of air-to-water heat pumps in new households in the period 2020-2030 is expected and a further 15% in the period 2030-2050.

In larger buildings, air-to-water heat pumps are still not common, and currently projects are therefore less standardised and have less competition. Therefore, a larger reduction can be possible. Equipment and installation reductions of 15% and 25% respectively in the periods 2020-30 and 2030-50 is assumed for both existing and new apartment complexes.

As mentioned, a simple learning-based analysis has also been conducted to validate the presented price developments. The complete description hereof can be found under Notes in [Appendix 2](#).

The fixed O&M costs include service and spare parts. The cost of a service is expected to see an annual reduction of 0.5% is assumed for all air-to-water systems corresponding to the expected annual reduction of mature technologies. Due to recent political agreements (in 2020), only a biannual service will be required by law for household systems, where it historically has been an annual requirement. From 2025, the costs for service are therefore reduced by 37.5% representing that only 25% of consumers will perform an annual service, while the rest will convert to biannual service.<sup>6</sup>

The cost of spare parts is also uncertain. Based on service subscriptions with and without spare parts include we estimate the spare parts cost to approximately 1.2% of the equipment price. For a typical air-water heat pump in a singly family house this corresponds to 900 DKK per annum incl. VAT. This percentage is maintained for the larger units in building complexes. It is assumed that the low-end heat pump has spare part costs 50% higher than the standard heat pump sold today.

The background for the SCOP-values presented in the datasheets are described under Notes in [Appendix 1](#). The cheaper air-to-water heat pumps is not described in this appendix as these are not as common in the Danish market and performed studies. For these, a linear relationship between equipment cost and expected SCOP using market data and data from the heat pump list (“Varmepumpelisten”) administered by the Danish Energy Agency is calculated. This relationship is used to determine how much lower the efficiency is expected to be for a cheaper product. Generally, the data show that the SCOP for floor heating is less affected by price compared to the SCOP for radiator systems. According to the calculated relationship, the cheaper air-to-water heat pump is expected to have approximately 4% lower SCOP for radiator systems and 1% lower SCOP for floor heating systems.

#### Specific for ground-source heat pumps:

Ground-source heat pumps can be categorized between category 3 and 4. For the installation and operation there is a potential for improvement. The time required for an installation is expected to decrease while the quality of the installation is expected to increase, resulting in higher performance of the heat pumps.

Ground-source heat pumps, unlike air-to-water heat pumps, have been present in the heating sector for a longer period, meaning the installation and equipment is further with regards to price and installation developments. As the interest and competition for heat pumps in general grows, the installation for ground-source heat pumps is also expected to decrease, but not as drastically as air-to-water heat pumps.

For systems installed in existing and new residential households, the cost of equipment is expected to fall 10% in the period 2020-30 and another 10% in the period 2030-50. For larger buildings, the price is expected to decrease a little more, since this market is currently less developed than that of smaller units. A decrease of 15% in the equipment cost is assumed instead.

The installation costs of ground-source heat pumps are largely due to man-hours and rental of equipment, where a reduction like that of air-to-water is not expected. A decrease of 10% for existing and new households is assumed for the periods 2020-30 and 2030-50, while a large decrease of 15% is expected for

---

<sup>6</sup>  $SP_{avg} = \frac{100\%+25\%}{2} \cdot SP = 62.5\% \cdot SP$

Where SP = price of heat pump service.

larger buildings. This is again since experience with larger systems is smaller and therefore expected to develop more.

Like for air-to-water heat pumps, the required service interval for ground-source heat pumps will be reduced to a biannual requirement, where it is expected that 25% will continue an annual service agreement.

### Specific for air-to-air heat pumps:

Regarding development in cost, it is assumed that, the air-to-air heat pumps belong to Category 4 as “Commercial Technologies, with large deployment so far”.

Air-to-air heat pumps have already seen a dramatic decrease in cost and is deployed to a much larger degree globally, compared to for example ground-source and air-to-water heat pumps. Furthermore, air-to-air heat pumps are very similar to split air-conditioners (often the same appliance can deliver both heating and cooling) meaning that the production numbers are immense, and the production plants are highly efficient.

Therefore, an annual reduction of the total cost by 0.5% per year is expected. This is the same reductions expected for other mature technologies such as gas and oil boilers.

### **Uncertainty**

The exact split between installation and equipment for the technologies is subject to uncertainty. This is mainly due to the fact, that the definition of what costs are attributed to equipment and installation is not always clear and suppliers may have differing definitions. Examples of the costs which can be interpreted as part of either price component are the mark-up on equipment and the costs of additional piping, fittings, etc. needed for the specific installation. The main component of the equipment costs is the heat pump itself (including indoor unit) while the main component of the installation costs is the cost of man-hours, where piping/fittings and mark-up are comparably smaller costs. Therefore, this uncertainty is not expected to drastically affect the split.

Prices of fuels hereunder also carbon and energy taxes affect the competitiveness of heat pumps. E.g. expensive biomass, gas or oil will imply that heat pumps will become more attractive. Alternatively, if the fuel prices drop relative to the electricity prices then heat pumps will become less competitive.

Also, the decision taken in June 2020 to reduce the Danish electricity tax was to 0.1 eurocent/kWh<sup>7</sup>, combined with increased efforts by the Danish government of convert the Danish heating sector to sustainable solutions, can increase the demand for heat pumps. A higher demand may in the long-term lead to lower prices but could also lead to bottlenecks among installers and thus to higher prices in short term.

Heat pumps are a rapidly developing market, and therefore the price and efficiency developments are especially uncertain.

Furthermore, the average COP achieved by any given installation is highly dependent on the specific conditions. Therefore, there is naturally a large uncertainty with regards to this value.

---

<sup>7</sup> 0.8 øre/kWh

### Economy of scale effects

Economy of scale especially applies to air-to-water and ground-source heat pumps as installation and auxiliary equipment. Within the typical capacity range for single family houses, a capacity increase of 100 % will typically increase investment cost for these systems by 5-25 % (including indoor unit and installation) depending on the brand and supplier. As installation cost for air-to-air heat pumps only form a small part of the investment, economy of scale effects are therefore more dramatic. A capacity increase of 1 kW increase the price by approximately 5-15% including installation where a typical air-to-air heat pump is about 5-9 kW.

### Additional remarks

Application of the data in the data sheet for concrete calculations of a project should be evaluated according to the specific local conditions.

For further reading about the heat pump technology see [14] (in Danish). For information about the technology, case stories, and the heat pump list<sup>8</sup> see [15].

---

<sup>8</sup> Varmepumpelisten



## Appendix 1: Background for energy efficiencies for heatpumps in the Technology Catalogue (in danish)

Author: Technological Institute

### Fastlæggelse af 2020 værdier for luft/vand og jordvarmepumper

Teknologikatalogets værdier for varmepumpevirkningsgrader er angivet i de data-blade, som er publiceret separat på Energistyrelsens hjemmeside. For luft-vand-varmepumpe er årsvirkningsgraden eksempelvis her angivet til 3,15 i eksisterende enfamiliehuse i 2020. Studier gennemgået på området i forbindelse med fastlæggelsen af teknologikatalogets værdier for varmepumpevirkningsgrader i 2020 er kort beskrevet i det følgende. Virkningsgraderne observeret i disse studier afspejler dog ikke teknologikatalogets værdier.

Der findes meget få studier, hvor installerede boligvarmepumpers virkningsgrader måles. Det er omkostningstungt og besværligt at installere måleudstyr og monitorere energieffektivitet under almindelig drift i boliger. De relevante studier gennemgås i det følgende i relation til en fastlæggelse af årsvirkningsgraderne.

Teknologisk Institut har i 2011 gennemført målinger i forbindelse med opgaven "Godkendelse af tilskudsberettigede anlæg, måling, dataindsamling og formidling" på grundlag af 170 varmepumper, primært jordvarmepumper. Studiet giver nogle af de mest detaljerede analyser, men som desværre også er næsten 10 år gamle, hvorfor der må forventes at have været en udvikling på både varmepumpernes effektivitet og kvaliteten af installationen i mellemtiden. Desuden påpegede dette studie en række fejl i installationerne, som påvirkede de målte virkningsgrader.

I 2015 blev projektet "Styr din Varmepumpe" afsluttet. Projektet indsamlede data fra op imod 300 varmepumper fordelt på forskellige typer og med spredning ud over Danmark. I 2017 blev projektet "Den gode Installation af Varmepumper" afsluttet. Projektet var baseret på data fra 21 danske varmepumper, som blev udvalgt for at få en bred repræsentation af typer og teknologier og ikke mindst virkningsgrader. Udvælgelsen af varmepumper skulle dække en stor variation i årsvirkningsgrader og derfor er studiet ikke statistisk repræsentativt.

Begge disse projekter giver mindre nuancerede data i forhold til varmepumpetyper og afgiversystemer og påpeger en del fejl i installationerne.

Herudover anslår "Evaluering af abonnementsordningen for varmepumper til boligejere" en samlet årsvirkningsgrad for varmepumper i rapporten fra marts 2019, som også kan nuancere data.

I slutningen af 2020 har Fraunhofer udgivet rapporten "Wärmepumpen in Bestandsgebäuden – Ergebnisse aus dem Forschungsprojekt "WPsmart um Bestand", som indeholder en række målte gennemsnitlige virkningsgrader fordelt på varmepumpetyper, og hvor der kan skelnes mellem gulvvarme og radiatorvarme. Studiet fremlægger årsvirkningsgrader for 19 luft-vand varmepumper og 11 jordvarmepumper i eksisterende byggeri i Tyskland, som spænder bredt i byggeår. Ligeledes beskriver Ecodesign studiet, i forbindelse med revisionen af "space heater" forordningerne, et engelsk studie, hvor der er foretaget praktiske målinger.

De nyere danske studier har lidt lavere virkningsgrader end Fraunhofer studiet, og er generelt ikke detaljerede i forhold til varmeoptager og varmeafgiversystem. "Styr din varmepumpe" anslår en gennemsnitlig virkningsgrad på 2,9. "Den gode installation af varmepumper" måler stor variation af

virkningsgrader med enkelte tilfælde af meget lave virkningsgrader under 2,0. Men studiet påviser også flere afgørende fejl i installationerne. Denne rapport konkluderer på baggrund af projektets undersøgelser og generelle erfaringer, at virkningsgraderne for "gode" og "rigtig gode" varmepumpeinstallationer vil være mellem 3,0 og 4,0, som vist i følgende:

"Evaluering af abonnementsordningen for varmepumper til boligejere" angiver en gennemsnitlig virkningsgrad på ca. 3,0 for installerede varmepumper.

Fraunhofer studiet angiver følgende virkningsgrader ud fra oplysninger om varmepumpetype, afgiversystem og gennemsnitlig fremløbstemperatur: luft-vand varmepumpe, radiator: 2,6 – 3,7; luft-vand varmepumpe, gulvvarme: 2,9 – 4,1; jordvarmepumpe, radiator: 3,2 – 3,8; jordvarmepumpe, gulvvarme: 3,6 – 4,6.

Desuden fastlægger Fraunhofer studiet en gennemsnitlig andel af varmepumpeproduktionen til varmt brugsvand på ca. 15% af den samlede varmeproduktion.

For data til Teknologikataloget tages der udgangspunkt i korrekt installerede anlæg. Der er desuden gjort en større indsats i de senere år for at opgradere installatørernes kompetencer, og ligeledes sker der en løbende udvikling af varmepumpernes virkningsgrader og betjening. Derfor vurderes det, at Fraunhofer studiets data kan bruges som et forsigtigt pejlemærke sammen med de overordnede vurderede værdier for en god installation ifølge "Den gode installation af varmepumper".

Varmepumpelisten indeholder med udgangen af 2020 SCOP data fra 186 varmepumper (dokumenteret vha. tredjepartsprøvning efter EN14825). Desuden kan data fra de 251 varmepumper, der var på listen i 2015 bruges til at vurdere udviklingen over tid. Varmepumpelistens data giver således mulighed for at vurdere, hvordan målte værdier for installerede varmepumper fra både de danske studier og Fraunhofer studiet varierer fra laboratoriemålte SCOP data.

SCOP data beskriver et årsvægtet gennemsnit af varmepumpens virkningsgrad baseret på "average" klimaprofilen fra EN14825. For at vurdere SCOP datas repræsentativitet i forhold til danske vejrforhold er temperaturfordelingen i EN14825 sammenlignet med danske klimaprofiler fra seneste DRY data fra 2013. Analysen viser, at forskellen i gennemsnitstemperaturen i opvarmningssæsonen (udetemperaturer mellem -10°C og +15°C) for de to klimaprofiler kun er i størrelsesordenen 0,5°C. Beregner man klimaprofilernes indflydelse på den beregnede SCOP bliver forskellen mellem de beregnede SCOP værdier for henholdsvis EN14825 temperaturdata og DRY temperaturdata kun mellem -0,4% og 3,8%. Derfor kan det konkluderes at temperaturfordelingen, som benyttes i EN14825 til beregning af årsvirkningsgraden SCOP, i høj grad repræsenterer danske forhold.

Varmepumpelistens SCOP værdier sammenlignes med virkningsgraderne fra Fraunhofer studiet, der som tidligere beskrevet vurderes at kunne repræsentere data for den "korrekte" varmepumpeinstallation i drift. Her kan det konkluderes at de målte data ligger en smule lavere for varmepumper i radiatoropvarmede boliger og 15-20% lavere for gulvvarme opvarmede boliger. En væsentlig del af denne forskel kan forklares med varmtvandsforbruget i boligen. Da varmt brugsvand skal produceres med højere temperaturer end fremløbstemperaturen til rumopvarmning, som er særlig aktuelt for gulvvarme opvarmning og i nogen grad for radiatoropvarmning i sommerperioden, vil den faktiske årsvirkningsgrad blive lavere, end hvis der kun var tale om rumopvarmning.

Ud fra denne viden om sammenhængen mellem "virkelighedens" målte værdier og Varmepumpelistens SCOP værdier målt i testlaboratorier kan værdierne i Teknologikataloget estimeres, når det antages at værdierne repræsenterer korrekte installationer.

På baggrund af varmpumpelistens SCOP data fastlægges en repræsentativ gennemsnitlig virkningsgrad for de enkelte varmpumpetyper afhængig af afgiversystemet. Disse værdier korrigeres for varmtvandsproduktionen ud fra forbrugsfordelingen vist i figur katalogets indledning (Table 4). Virkningsgraden ved brugsvandsopvarmning antages at have en gennemsnitlig værdi på 2,2.

De fundne værdier er vurderet i forhold til tilgængelige målte data. For varmpumper til gulvvarme vurderes de fremkomne værdier at være for høje sammenlignet med måledata på trods af brugsvandskorrektionen. Derfor korrigeres de yderligere 6-9% ned svarende til ca. 0,2-0,4 i årsvirkningsgrad.

### **Luft/luft varmpumper**

For luft/luft varmpumper findes der ikke anvendelige måledata fra faktiske installationer, da det er meget vanskeligt at måle varmproduktionen uden for et testlaboratorium.

Til gengæld er der færre påvirkninger af den faktiske virkningsgrad, idet der ikke produceres varmt brugsvand, og installationerne typisk er simple. Derfor vælges der at tage udgangspunkt i værdierne fra varmpumpelisten, som består af laboratorieefterprøvede virkningsgrader, som er beregnet på baggrund af repræsentative årstemperaturprofiler fra En14825.

### **Brugsvandsopvarmning med luft/luft varmpumper**

I den tidligere version af dette Teknologikatalog var det antaget at luft/luft varmpumper også vil dække brugsvandsopvarmning på længere sigt, hvilket var indarbejdet i tallene fra 2030. På baggrund af samtaler med eksperter på Teknologisk Institut vurderes dette urealistisk og vil kun ske i sjældne tilfælde. Det skyldes at luft/luft varmpumper er en relativt prisbillig installation med største udbredelse i ikke-helårsboliger, hvor en større yderligere investering (og opkobling til brugsvandssystem) vil være omstændelig. I de tilfælde, hvor det kunne komme på tale, vil luft/vand varmpumper ligeledes udgøre et konkurrerende produkt.

### **Fremskrivning til fremtidige værdier**

Der findes ikke måledata fra varmpumpeinstallationer, der på nogenlunde fyldestgørende vis kan belyse udviklingen i varmpumpers virkningsgrader over en årrække. Fremskrivningen af varmpumpernes virkningsgrader baseres derfor på data fra varmpumpelisten i 2020 sammenlignet med 2015. Det giver mulighed for at analysere udviklingen i virkningsgrader over den seneste fem-års periode, som kan benyttes til at estimere den fremtidige udvikling. Som udgangspunkt benyttes den procentvise udvikling i virkningsgrader som grundlag for udviklingen frem til 2025, hvorefter udviklingsgraden nedskaleres i de følgende år.

<i>Udvikling i SCOP værdier fra 2015 til 2020 på varmepumpe listen</i>			
	5 mest effektive [gulvvarme/radiator]	5 mindst effektive [gulvvarme/radiator]	Gennemsnit [gulvvarme/radiator]
Luft/Vand varmepumper	8% / 8%	10% / 3%	11% / 4%
Jordvarmepumper	0% / -1%	4% / 4%	2% / 1%
Luft/Luft varmepumper	8%	4%	7%

Ovenstående data viser, at luft-vand varmepumperne har udvist et større udviklingspotentiale i de forgangne fem år sammenlignet med jordvarmepumperne. Derfor vurderes det, at luft/vand varmepumperne vil have en lidt større effektivitetsforbedring over de kommende år sammenlignet med jordvarmepumperne. For alle typer af varmepumper antages at forbedringen i effektiviteten vil være aftagende på længere sigt.

### **Værdier for varmepumper til lejlighedskomplekser (apartments)**

Der er kun i begrænset omfang målte data til rådighed for de større varmepumpeinstallationer til lejlighedsbyggeri.

Mange opvarmningsløsninger til lejlighedskomplekser med varmepumper er hybridløsninger, hvor naturgassen står for særligt spidslasten af opvarmningsbehovet. Denne type løsninger er beskrevet under hybridløsningerne (Teknologikataloget forventes udvidet med hybridløsninger i 2021), hvor de "rene" varmepumpe løsninger beskrives her.

Varmepumper til lejlighedskomplekser kan findes i forskellige konfigurationer. En løsning med decentral brugsvandsopvarmning, hvor varmepumpen hele tiden skal producere varme ved tilstrækkeligt høje temperaturer til, at det kan bruges som varmt brugsvand. Alternativt en løsning, hvor en varmtvandsbeholder er placeret centralt i varmecentralen og forsyner med varmt brugsvand direkte. Den sidste løsning er den mest effektive.

I værdierne i Teknologikataloget tages udgangspunkt i en central løsning. Det betyder at driftsmønstret i nogen grad vil ligne mønstret fra enfamilieshuse. Dog estimeres det at de gennemsnitlige fremløbstemperaturer vil være en smule højere, da varmepumpen skal forsyne forskellige familier, der vil have varierende komfortkrav. Ligeledes kan der være et lidt større ledningstab på grund af længere føringsveje.

Dialog med leverandører og producenter fortæller at de primære løsninger til lejlighedsbyggeri består i traditionelle varmepumpeunits, som bygges sammen i kaskadeløsninger afhængigt af det ønskede behov. Der er således ikke tale om større industrielle units og derfor kan der heller ikke forventes en øget virkningsgrad som følge af installationernes størrelse.

På baggrund heraf vurderes det at virkningsgraderne ved opvarmning af lejlighedskomplekser med varmepumpe bliver lidt lavere sammenlignet med enfamilieshuse, da der forventes et større tab i distributionen af varme og varmt brugsvand. Der estimeres årvirkningsgrader på ca. 90 % af værdierne for enfamilieshuse, som er verificeret i forhold til oplysninger indhentet fra producenter og leverandører.

## Kilder

### Luft/vand + Væske/vand

- Data fra Varmepumpelisten hentet oktober 2020, Energistyrelsens hjemmeside, spareenergi.dk
- Data fra Varmepumpelisten 2015, Energistyrelsens hjemmeside, spareenergi.dk
- Den Lille Blå om varmepumper, udgivet af Dansk Energi 2019
- Wärmepumpen in Bestandsgebäuden – Ergebnisse aus dem Forschungsprojekt "WPsmart um Bestand" udgivet af Fraunhofer juli 2020
- Review Study: "Space and combination heaters" Task 4 "Technologies" udgivet juli 2019
- EU energimærkningsforordning 812/2013
- Den gode installation af varmepumper, januar 2017
- Godkendelse af tilskudsberettigede anlæg, måling, dataindsamling og formidling. Udgivet august 2011
- Diverse varmepumpeeksperter fra Teknologisk Institut

### Luft/luft

- Data fra Varmepumpelisten hentet oktober 2020, Energistyrelsens hjemmeside, spareenergi.dk
- Data fra Varmepumpelisten 2015, Energistyrelsens hjemmeside, spareenergi.dk
- Den Lille Blå om varmepumper, udgivet af Dansk Energi 2019
- Task rapport 6: Review of regulation 206/2012 and 626/2011 Air conditioners and comfort fans – Design options" May 2018
- EU energimærkningsforordning 812/2013
- Eksisterende forordninger 206/2012 og 626/2011, samt forslag til revisioner fremlagt 2019.
- Diverse varmepumpeeksperter fra Teknologisk Institut

### Varmepumper til "apartments"

- Samtale med Bosch, 2020
- Samtale med DVI (Dansk Varmepumpe Industri), 2020
- Diverse varmepumpeeksperter fra Teknologisk Institut

### Appendix 2: Learning-based projection

The above-described developments in price are based on interviews and experience from the sector. To validate the size and speed of these price developments a learning-based projection is also considered. The following is not an in depth analysis of the heat pump market but should be seen as an indicative analysis of the theoretical price development under certain developments and assumptions as described below.

This is a theoretical method for estimating price developments based on a so-called learning rate. The learning rate describes the price reduction for every doubling of capacity installed or units sold for a given technology.

The Reflex project Technological Learning in Energy Modelling [15] has assessed learning curves for different energy technologies, including heat pumps. Here the heat pump technology is evaluated to have a learning rate of 10% but also concludes that this value is very uncertain and can vary from country to country. For comparison, the same study found the following learning rates for other technologies:

- Solar PV: 18.6-21.4% depending on type
- CCS: 2.1 – 2.2% depending on fuel, but 11-12% for industrial CCS.
- Li-ion battery storages: 12.5-15.2% depending on scale.
- Fuel cell stacks: 18%
- Wind systems: 5.9% for onshore systems and 10.3% for offshore systems

It is assumed that the investment price of heat pumps in Denmark will follow the developments in the EU and therefore, it is necessary to look at the expected number of heat pumps in Europe and not just Denmark. Table 6 shows an estimate of the distribution of individual heating in Europe [16] [17]. Boilers are assumed to be mainly based on oil and gas. With current climate goals in the EU and individual countries, a shift from boilers to heat pumps and district heating is expected.

<i>Number of heating units</i>	<b>2019</b>
<i>Air-to-water:</i>	1.885.000
<i>Ground-to-water:</i>	1.555.000
<i>Exhaust-air:</i>	324.000
<i>Air-to-air:</i>	5.400.000
<i>Boilers</i>	94.000.000
<i>Stove</i>	58.000.000
<i>Electric radiators</i>	28.000.000

**Table 6: Estimated distribution of individual heating installations in EU based on statistics from the European Heat Pump association. Note the statistics for heat pumps only cover EU21, but all large member states are represented.**

To begin, it is assumed that boiler installations will be replaced (or supplemented) with another heat source with the following distribution of alternative sources. Exhaust and air-to-air heat pumps are generally supplementary heat sources.

- District heating: 25 %
- Air-water HP: 45 %
- Ground-source HP: 10 %
- Air-to-air HP: 15 %

- Exhaust HP: 5 %

Overall, two scenarios are considered: 1) The number of boilers replaced/supplemented is 30% in 2030, 60% in 2040 and 70% in 2050 and 2) The number of boilers replaced/supplemented is 10% in 2030, 30% in 2040 and 50% in 2050 compared to today. These two scenarios combined by the distribution of alternative heat sources, results in the development of the number of heat pumps described in Figure 43. Table 7 shows the relative number of heat pumps compared to 2019.

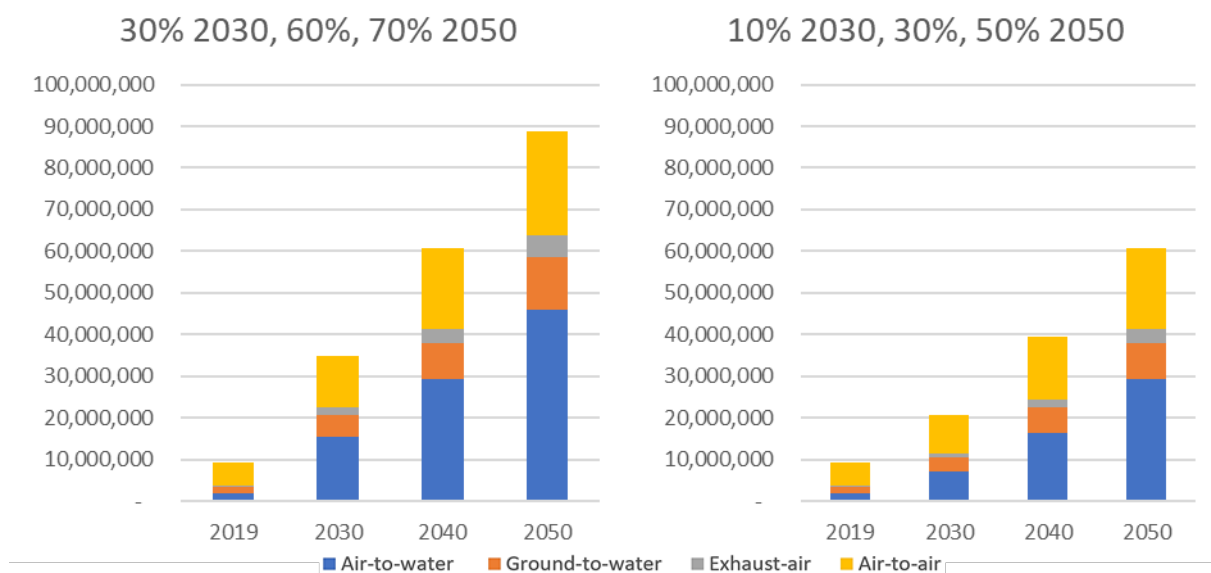

Figure 43: Number and type of heat pumps in the 2 scenarios

Relative development	2019	2030	2040	2050
Air-to-water	1	8	15	24
Ground-to-water	1	3	6	8
Exhaust-air	1	6	11	17
Air-to-air	1	2	4	5

Table 7: The relative development for the number of heat pumps compared to 2019.

Figure 44 shows the price developments for 4 different learning curved scenarios and the developments described in the datasheet:

1. 10%: Learning curve predictions based on unit increase described in Table 7 combined with a learning rate of 10%.
2. Same as 1) but with a more conservative learning rate of 5%.
3. The more conservative version of 1) where the boiler reduction instead is 10% in 2030, 30% in 2040 and 50% in 2050. The learning rate is 10%
4. Same as 3) with a more conservative learning rate of 5%.

The learning rate calculations indicates that the price developments presented in the datasheets are neither very optimistic nor conservative. The price reductions for air-to-water heat pumps and ground source heat pumps in the datasheets follow a development between the scenarios with learning rates of 10% and 5% for a more conservative development in Europe, but close to a learning rate of 5% for the more progressive

scenario. In 2030 the investment costs in the datasheets are decreased by 14% and 10% for air-to-water and ground-sourced heat pumps respectively while the 4 learning-based scenarios show a range of 9-27% and 5-17% respectively for 2030 compared to 2019.

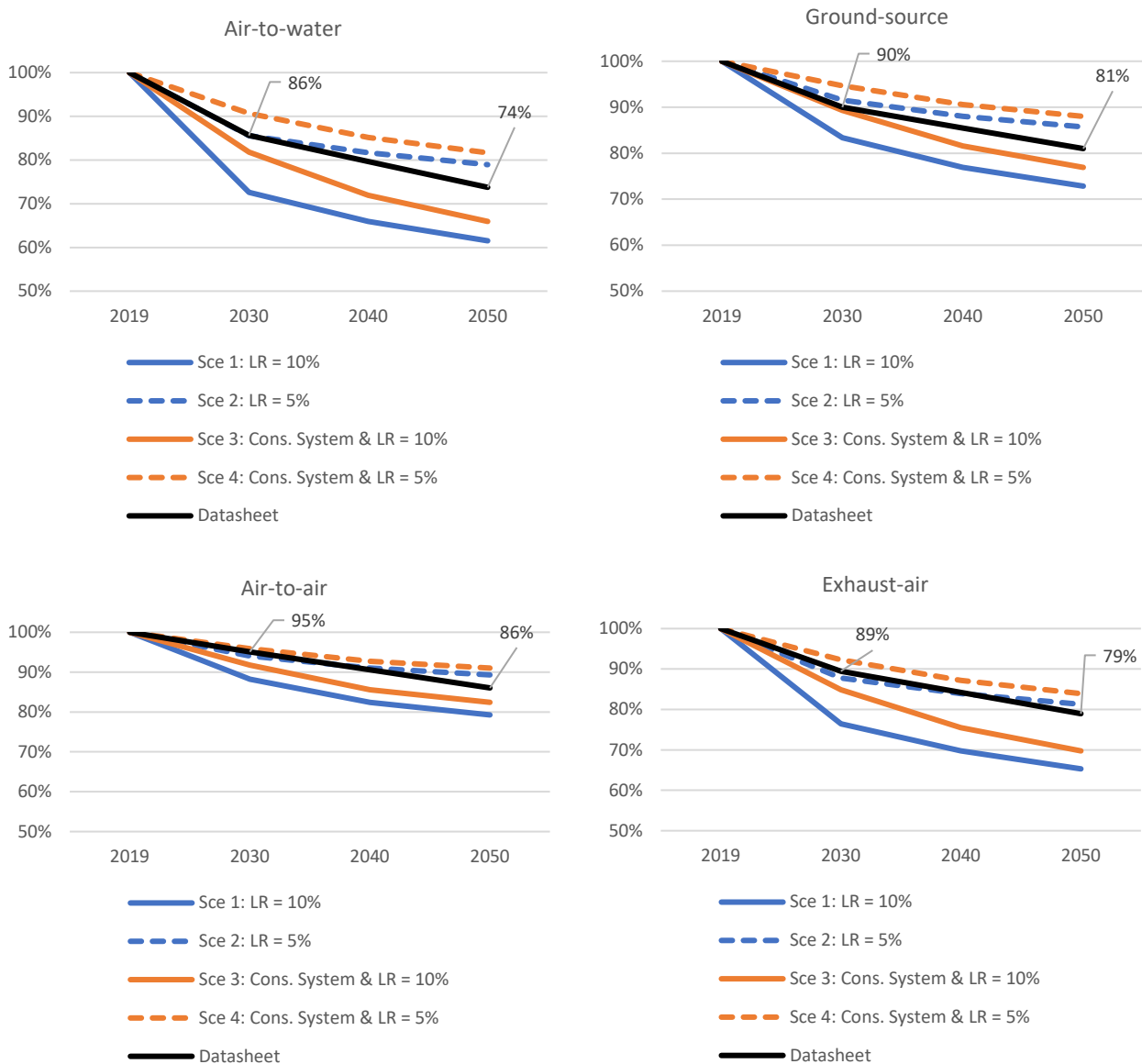

Figure 44: Expected investment price reduction compared to 2020 for each type of heat pump. See description of scenarios in text.

For air-to-air and exhaust heat pumps, the development described in the datasheet tend to follow the more conservative learning-based estimations towards 2030.

The learning curve estimates presented here are theoretical and based on some simple assumptions about the development of the market in Europe.

Potentially it could be argued that the number of stoves will also be reduced, which would further increase the number of heat pumps. Furthermore, new buildings are also not considered, where it is expected that generally a larger share of these will choose heat pumps compared to the existing buildings.



It is assumed that the learning-curve reductions affect the full investment, because learning is also expected regarding installation hereunder improved product design to simplify installation.

## Quantitative description

See separate Excel file for Data sheets.

## References

- [1] Metrotherm. <https://www.metrotherm.dk/produkter/varmepumper/luft-vand-varmepumper/metroair-i>. 2020
- [2] Bosch. <https://www.bosch-thermotechnology.com/dk/da/ocs/privat/compress-7000i-aw-758037-p/>. 2020
- [3] Vvs-eksperter.dk. [https://www.vvs-eksperter.dk/varme-og-klima-varmepumpe-jordvarme-jordvarmepumpe-copmax-10-kw-med-siemens-styring-346019210?gclid=CjwKCAjw8-78BRA0EiwAFUw8LHOZWVY\\_8x0PGtcqpg8AAWVuaStjKAlD4sPxl6DLT0L6OwLxHz2uxoCQYUQAvD\\_BwE](https://www.vvs-eksperter.dk/varme-og-klima-varmepumpe-jordvarme-jordvarmepumpe-copmax-10-kw-med-siemens-styring-346019210?gclid=CjwKCAjw8-78BRA0EiwAFUw8LHOZWVY_8x0PGtcqpg8AAWVuaStjKAlD4sPxl6DLT0L6OwLxHz2uxoCQYUQAvD_BwE). 2020.
- [4] Vvs-eksperter.dk. <https://www.vvs-eksperter.dk/varme-og-klima-varmepumpe-jordvarme-bosch-compress-6000-lw-6-kw-jordvarmepumpe-346737006>. 2020
- [5] Nilan. <https://www.nilan.dk/da-dk/forside/loesninger/boligloesninger/kompaktloesning/compact-p-cts700>. 2020
- [6] Billigventilation.dk. <https://www.billigventilation.dk/shop/panasonic-cz25tke-varmepumpe-4533p.html>. 2020
- [7] Energistyrelsen, "Beregning af SCOP for varmepumper efter En14825", 2011
- [8] Interview med VS Automatic
- [9] COWI, "Evaluering af Abonnementsordningen for varmepumper til boligejere", 2019
- [10] Website investigation of various suppliers.
- [11] Interviews with various installation companies.
- [12] Interview with Bosch.
- [13] The Danish Energy Agency, "Varmepumper installeret halvårligt fra 2009 til første halvår 2020", 2020. [https://ens.dk/sites/ens.dk/files/Statistik/udvikling\\_i\\_salg\\_af\\_varmepumper\\_fra\\_2009.pdf](https://ens.dk/sites/ens.dk/files/Statistik/udvikling_i_salg_af_varmepumper_fra_2009.pdf)
- [14] Dansk Energi, "Den lille blå bog om varmepumper", 2019. [https://elforsk.dk/sites/elforsk.dk/files/media/dokumenter/2019-04/Den\\_Lille\\_Blaa\\_Om\\_Varmepumper.pdf](https://elforsk.dk/sites/elforsk.dk/files/media/dokumenter/2019-04/Den_Lille_Blaa_Om_Varmepumper.pdf)
- [15] A. Louwen, M. Junginger, A. Krishnan, "Technological Learning in Energy Modelling: Experience Curves", REFLEX project, 2018. [http://reflex-project.eu/wp-content/uploads/2018/12/REFLEX\\_policy\\_brief\\_Experience\\_curves\\_12\\_2018.pdf](http://reflex-project.eu/wp-content/uploads/2018/12/REFLEX_policy_brief_Experience_curves_12_2018.pdf)
- [16] S. Pezzutto, S. Croce, S. Zambotti, L. Kranzl, A. Novelli, P. Zambelli. "Assessment of the Space Heating and Domestic Hot Water Market in Europe—Open Data and Results". Energies, 2019.
- [17] Statistics from the European Heat Pump association, [http://www.stats.ehpa.org/hp\\_sales/story\\_sales/](http://www.stats.ehpa.org/hp_sales/story_sales/)
- [18] Ministry of Environment and Food of Denmark, "Utsigtet tab af Fgasser ved demontering af klimaanlæg og varmepumper Udredningsprojekt", 2020. <https://www2.mst.dk/Udgiv/publikationer/2020/02/978-87-7038-159-8.pdf>
- [19] SparEnergi.dk, "Varmepumpe på abonnement", <https://sparenergi.dk/forbruger/varme/varmepumper/varmepumper-paa-abonnement>

## 208 Hybrid gas and electric heat pump

### Contact information

Danish Energy Agency: Filip Gamborg, [fgb@ens.dk](mailto:fgb@ens.dk), Martin Rasmussen, [mra@ens.dk](mailto:mra@ens.dk)

Author: Ea Energy Analyses

### Publication date

june 2021

### Amendments after publication date

Date	Ref.	Description

## Qualitative description

### Brief technology description

A hybrid heating solution, consisting of an electric heat pump combined with a condensing gas boiler, is commonly referred to as a hybrid heat pump. It can also be called other names such as hybrid boiler or hybrid heat pump boiler. Hybrid heat pumps have gained increasing interest in recent years as a solution to significantly reduce the use of gas for heating buildings. In hybrid heat pump systems, the heat pump component provides most of the heat demand, where the gas boiler boosts and supports the heat production, when this is beneficial, for example during periods of high electricity prices and/or cold periods. By combining these two technologies, hybrid heat pumps will typically have lower variable heat costs compared to a traditional gas boiler while overcoming some of the disadvantages of heat pumps, for example the decreased COP in cold periods.

The heat pump component must be a type capable of delivering heat to a water-based distribution system, for example an air-to-water, ground-source, or ventilation heat pump. A hybrid heat pump can also vary with regards to the non-heat pump component, which in principle can be any heat producing unit, for example an oil or biomass boiler.

This chapter will focus on the hybrid heat pumps consisting of an air-to-water heat pump and a gas boiler, since this combination is expected to remain the most common, but there are many different types of possible combinations. For an in-depth presentation of the two technologies, consult their respective chapters.

A consumer can acquire a hybrid heat pump system by using one of the following three solutions:

- Add-on solution: The consumer adds a heat pump unit to a heating system consisting of an existing standard condensing gas boiler
- Package solution: The consumer buys a complete system, consisting of a new condensing gas boiler and a heat pump. The two units are separate, like in the add-on solution, but sold as a package where the units are chosen to integrate well and according to the customer needs.

- Integrated solution: The consumer buys a full system, where the gas boiler and the heat pump are combined into a single, integrated, and optimized unit by the manufacturer.

Figure 1 illustrates the three solutions. The choice of solution depends on the consumer's preferences and requirements and the specifics of the building, in which it needs to be installed. For example, the add-on and package solutions will generally require more space but can be tailored to the specific needs of the building, while the integrated solution is a space efficient unit and easier to install but has predefined specifications. Moreover, the add-on solution will typically require the smallest investment, whereas installation costs could be higher. The range of integrated systems available in the Danish market today is limited. Figure 1 illustrates a single-family home, but the same solutions apply to larger buildings.

Often, package or integrated solutions are typically recommended as opposed to add-on solutions to ensure high system efficiency and avoid compatibility challenges. [1]

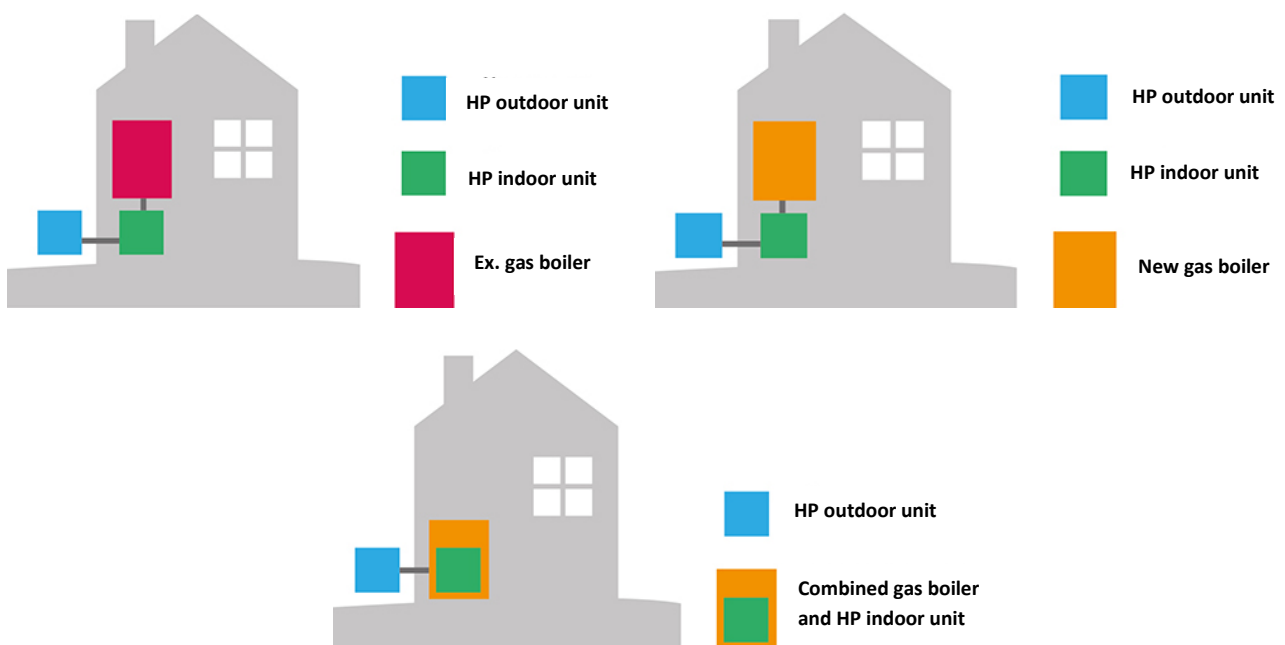

Figure 45: Principle of the three hybrid heat pump solutions. Left to right: add-on, package, and integrated solution [2]

A heat pump's COP, "Coefficient of Performance", describes the heat output per drive energy input, or electricity in the case of electric heat pumps, and is highly dependent on its operating conditions. Heat pumps draw heat from a low temperature source (input heat) and convert the heat to a higher temperature (output heat) through a closed process. The heat delivered is the sum of the heat absorbed from the environment and the electrical energy added via the compressor. The COP can be calculated by the formula below.

$$COP = \frac{\text{Delivered heat}}{\text{Electricity consumed}} = \frac{6 \text{ kW}}{2 \text{ kW}} = 3$$

The COP is often in the interval 3-5, meaning they deliver 3-5 times more heat energy than electricity consumed.

The temperature difference between the temperature of the heat source and the temperature level of the heat delivered strongly influences the COP. When the difference in temperature between the heat source and heat delivery decreases, the COP will increase and vice versa. This implies that the COP will vary e.g. according to the season. During the winter, the low outdoor temperature combined with a higher temperature required by the heating system results in a higher temperature difference and therefore a lower COP compared with milder days.

In a hybrid heat pump system, the heat pump does not have to cover the entire heat demand by itself and will typically not be dimensioned to do so, since the gas boiler can assist, when this is advantageous.

There are many different possibilities for the operation strategy for the hybrid system. Commonly, the heat pump will cover the full demand when the outside temperature is sufficiently high (for example 3°C), whereas the demand will be covered by the boiler when the outside temperature is low (for example less than -3°C [1]). In between these temperatures, the heat pump and boiler will share the heat production. For the heat pump and boiler to operate efficiently they should both be capable of operating at partial load.

Instead of determining the heat production split based on outside temperature, another way is to allow the heat pump to generate heat up until a certain compressor pressure. The compressor is the component in the refrigeration cycle which generates pressure. A larger temperature difference between the input and output increases the required compressor pressure and electricity consumption. If the pressure is limited, the heat pump may not be able to deliver sufficiently high output temperatures when the input temperature is low. In this case, the boiler provides the difference. This operation strategy minimises strain on the heat pump compressor while ensuring high heat pump efficiency.

It can be beneficial for the gas boiler to provide most or all of the domestic hot water heat demand, since the minimum required temperature hereof is 55°C, no matter the season, to avoid bacterial growth such as Legionella. The heat pump can pre-heat the domestic water, while the gas boiler provides the remaining heat, but in some cases the gas boiler will just provide the full domestic hot water demand.

The operation may also be optimized according to price signals from the power market and time-of-use tariffs or local price signals, thereby reducing the strain on the local power grid. This may again diminish or postpone the need for grid reinforcement, while also lowering the electricity costs.

Compared to pure heat pump systems, the hybrid system is more suited for providing regulating power for balancing the electricity grid, because it can shift between two supply options. The benefit of this flexibility is expected to increase as the share of electricity produced by intermittent, renewable energy sources, such as wind and solar, increases – and the loads in the distribution grids surge, as more and more households are equipped with electric vehicles and heat pumps.

The hybrid heat pump is typically dimensioned to ensure that the heat pump can provide approximately half of the expected peak heat demand of the building<sup>9</sup>. A heat pump of this dimension is expected to deliver approximately 70-90% of the annual heat demand. Typically, the gas unit is dimensioned to provide the full peak demand.

---

<sup>9</sup> Typically calculated for an external temperature of -10°C.

### Input

Inputs for hybrid heat pumps consisting of an air-to-water heat pump and a gas boiler are ambient air, electricity and gas.

### Output

Hot water for space heating and domestic hot water.

### Typical capacities

The heat capacity of the heat pump component in a hybrid solution for a residential household typically lies in the range of 3 kW to 9 kW, where 5 kW is commonly installed in existing single-family house. This size will be able to deliver most of the heat demand of such a house. For comparison, the same building with a pure heat pump solution is expected to require a heat pump of approximately 7 kW. Heat pump capacities are defined at -7/55 degrees.

Existing gas boilers are typically larger than strictly necessary, mainly due to gas boilers having relatively small economy of scale effects. In the data sheet, a system including a 20 kW gas boiler for households is assumed, but the costs are not expected to be significantly different for a system with a smaller or larger boiler.

In larger buildings, the dimensions will depend on the specifications of the building, but generally the heat pump is still dimensioned to deliver 80-90% of the heat demand. In larger buildings, cascade heat pump systems are common, where the heat pump component consists of multiple smaller heat pumps connected in series. As in smaller buildings, the gas boiler will often be dimensioned to supply the full heat demand.

### Regulation ability

Many modern heat pumps are equipped with an inverter/frequency converter, so they can operate at part load. The fact that the heat pump is supported by a gas boiler means that the heat pump can operate at a lower than maximum load, which decreases the strain on the components. Heat pumps can typically operate at as low as 20-30% of their maximum load. Likewise, most gas boilers are able to modulate down to about 20-25% of the nominal maximum output.

The introduction of more smart controls can increase automatic operation surveillance and communication between the two units, ultimately resulting in a better performing system.

### Advantages/disadvantages

The hybrid heat pump can bypass some of the disadvantages of both traditional gas boilers and electric heat pumps.

Hybrid heat pumps consume less gas compared to a traditional gas boiler, and therefore also have lower emissions. The gas boiler typically only delivers 10-20% of the annual heat consumption. Furthermore, the share of green gas in the gas supply is expected to increase, further decreasing the emissions. The combination of a heat pump and boiler enables minimization of heating costs, and these will typically be lower compared to a single boiler and/or heat pump.

Heat pumps have the disadvantage that their efficiency decreases, as the temperature difference between the heat source and delivered heat increases. This effect can be reduced in a hybrid heat pump, because the gas boiler can boost the temperature of the heat delivered by the heat pump, so the bulk of the heat pump operation will be at a lower temperature difference and therefore higher efficiencies. Since the energy not

delivered by the heat pump is delivered by the boiler instead, the total system efficiency does not necessarily increase. Below is a calculation example for the system efficiency for a building with a heat demand of 18,1 MWh where the heat pump delivers 80% of the heat demand:<sup>10</sup>

$$Electricity = \frac{HP_{out}}{COP} = \frac{18,1 \text{ MWh} \cdot 80\%}{3,35} = 4,3 \text{ MWh}$$

$$Gas = \frac{GasBoiler_{out}}{Eff.} = \frac{18,1 \text{ MWh} \cdot 20\%}{92\%} = 3,9 \text{ MWh}$$

$$Eff_{sys} = \frac{Heat \text{ demand}}{Electricity + Gas} = \frac{18,1 \text{ MWh}}{4,3 + 3,9 \text{ MWh}} = 220\%$$

As previously mentioned, a hybrid system can also operate based on the electricity price and can support the power grid by reducing or increasing electricity consumption.

Another advantage of a hybrid heat pump is that the individual components do not have to be dimensioned to deliver the full heat demand. As discussed in the section on gas boilers, the economy of scale effect of gas boilers is small, but the same is not true for heat pumps. Reducing the capacity of the heat pump reduces the investment cost of the heat pump unit, but since the hybrid solution requires both a heat pump and gas boiler, the total cost is not dramatically different from simply installing a full air-to-water heat pump solution for an existing single-family house. A package solution (separate, new boiler and heat pump) requires installation of two separate units, which increases the installation time and price compared to the installation of a heat pump or gas boiler alone.

A package solution requires more space indoors than both the gas boiler and pure heat pump solutions, which can pose a challenge in some houses. On the other hand, the indoor unit of integrated solutions generally require less space than the indoor component of a pure heat pump.

Since the hybrid solution has two different heat producing components, it adds a layer of security for the owner. If the boiler or heat pump is out of operation, the other component can still deliver most if not all of the heat demand. This may also be an important factor for consumers who are hesitant in choosing a full heat pump solution due to the fear of it not being able to deliver enough heat on the coldest days.

The ability of one unit to deliver all or most of the heat demand adds flexibility regarding time-dependent tariffs, where periods with high tariffs can be avoided.

There is a small number of houses where a pure heat pump solution is not well suited, for example buildings with unusually high temperature requirements for the space heating. In these buildings, a hybrid solution may be better suited.

<sup>10</sup> The heat demand does not have to be defined to calculate the system efficiency but is done so in the example for easier understanding. The system efficiency can be calculated without defining the heat demand:  $Eff_{sys} =$

$$\frac{1}{\frac{Share_{HP}}{Eff_{HP}} + \frac{Share_{boiler}}{Eff_{boiler}}}$$

By reducing the HP size in the hybrid technology and supporting heat production with the gas boiler in cold periods, the noise generation is decreased compared to a corresponding pure heat pump system. Therefore, it may be possible to install the solution where a pure heat pump solution would not be suitable.

Since the heat pump does not have to deliver the full heat demand, the strain on its components is less. This can increase the economic lifetime of the system. Similarly, the gas boiler also operates less, meaning its lifetime is expected to be improved.

For newer gas boilers, the add-on solution could be an affordable and cost-effective way to upgrade the heating system, assuming there are no compatibility issues.

Both the gas boiler and the heat pump require maintenance. Some companies offer combined service of both the boiler and the heat pump, but since the amount of work is larger, the fixed O&M cost would typically be slightly higher than that of pure boiler and pure heat pump solutions, but can vary depending on the specific company. One source reported that a service of a hybrid heat pump could cost 1.5 times that of a pure air-to-water heat pump system, whereas another source mentioned that the cost of maintaining a hybrid heat pump was almost the same as for an air-to-water heat pump system [8]. In the datasheets the cost of service is set as 25% higher than that of a corresponding air-to-water heat pump.

### Environment

The environmental effects of a hybrid heat pump is the sum of the environmental effects of the gas boiler and the air-to-water heat pump. These are shortly summarized below, and it is recommended to read the corresponding section for the two technologies for more details.

Gas boilers have NO<sub>x</sub> and CO emissions, but these are quite low. Since gas boilers generally burn natural gas, they also emit CO<sub>2</sub>. With increasing injection of biomethane (about 20% in 2020) into the grid, the carbon footprint of gas boilers is declining. Furthermore, increased use of intelligent controls may also reduce the emissions.

The environmental effect of the air-to-water heat pump relates to the electricity consumption, the refrigerant, and the generated noise. The environmental impact due to the use of electricity will depend on the way the electricity is produced.

Today, almost all heat pumps for individual heating on the Danish market use synthetic refrigerants. These are known as HFCs (hydrofluorocarbons) which are fluorinated gases (F-gases) that possess a potent greenhouse effect and are covered by the Kyoto Protocol. There are many different refrigerants based on HFCs.

The most common refrigerants based on HFCs have Global Warming Potentials (GWP) of about 1,500 to 4,000 compared to CO<sub>2</sub>, which has a GWP of 1. In the newer models of heat pumps sold today, R32 and R410A are especially common. R32 has a lower GWP at about 675 compared, where R410A has a GWP of 2,088.

The refrigerant is contained in a closed cycle that should not leak. Nonetheless, leaks can happen for example if the heat pump is damaged or disassembled.

Danish Legislation bans the use of HFCs in heat pumps with more than 10 kg of refrigerant. Heat pumps for individual heating typically contain less than 2 kg of refrigerant, meaning that the ban does not affect this

segment. There are, however, some heat pump models available with natural refrigerants such as CO<sub>2</sub> or propane (R290), but this is still a minority. R290 has a GWP of less than 1 and has the advantage that a temperature of 75 degrees can be achieved. The refrigerant is also cheaper; however, the range of compressors is not that large yet. R290 cannot be used for units installed inside the home (split units), because it is flammable.

The other main environmental impact is the noise the outdoor unit of the heat pump generates. The amount of noise generated is correlated with the quality, type, and size of the heat pump. The noise level is regulated by law and must be max 35 dB during the night and max 45 dB during the day measured at the property boundary. Since most heat pumps generate more noise than this, they must generally be placed at some distance from the boundary. The heat pump in a hybrid configuration is typically smaller, and therefore the generated noise can be lower compared to a corresponding pure heat pump solution.

### Research and development perspectives

The hybrid heat pumps will benefit from the developments in both gas boilers and heat pumps. Gas boilers by themselves are a mature and commercial technology with large deployment, and they are highly efficient. Significant development in the technology is not expected, but there may be optimizations regarding boilers in a hybrid context, for example smart grid and control.

On the other hand, air-to-water heat pumps have developed rapidly in the last 10 years, as the interest in them and sale grows, and they are expected to continue developing. The experience with heat pumps among installation companies has been low, which has resulted in suboptimal installation. This is expected to improve due to the growing market and a focus on increasing competencies of installation companies via measures such as RE-certifications (VE-godkendelsesordning). This also means that the installation costs will decrease, as companies get more experienced with installing these systems.

Besides the installation, the noise of the outdoor unit is expected to continue to decrease. Furthermore, the developments within refrigerants can potentially increase the maximum temperature, the heat pump can deliver, to 75°C.



**Examples of market standard technology**



**Figure 47: Daikin Altherma, integrated hybrid heat pump (unit solution) 5 kw heat pump, 32kW gas boiler [3]**



**Figure 48: Package solution consisting of ELCO Thision Mini gas boiler and air-to-water ELCO Aerotop Monobloc heat pump. [4]**



**Figure 46: A hybrid heat pump by Panasonic for larger buildings and heat demands.**

**Prediction of performance and costs**

As mentioned earlier, package or integrated solutions are often preferred to add-on solutions, and therefore the datasheets focus on these solutions.

**- Costs**

There are currently no statistics for the sale of hybrid heat pump systems in Denmark but according to suppliers, the sale is limited.

The demand for hybrid heat pumps is higher and growing in other European countries, including England, the Netherlands, and Austria [6][9], and therefore, despite the lack of activity in Denmark, the costs are still expected to decrease, and the efficiency to increase. Also, as stated earlier, hybrid heat pumps will benefit from the developments within air-to-water heat pumps. Moreover, increased interest in hybrid solutions will increase competition among producers of boilers and heat pumps to create products more capable of efficient integration.

The investment costs of hybrid heat pumps described in the datasheets are based on market research and interviews with companies offering hybrid solutions. Due to the limited market of hybrid heat pumps, this price is validated using data for pure heat pump and gas boiler solutions separately, which is expected to be representative, especially with regards to a package solution consisting of a separate boiler and heat pump.

Since a portion of the cost pertains to the gas boiler, the total costs are not expected to decrease as drastically as pure air-to-water heat pumps. For existing households, it is assumed that the cost of the equipment for the heat pump will decrease by 10% in the period 2020-30 and again in the period 2030-50, while the cost of the equipment for the gas boiler is only expected to decrease 0.5% annually (4,9% in the period 2020-30 and 9.5% in the period 2030-2050). For this reason, the cost of the equipment of a hybrid heat pump is expected to decrease by 8% towards 2030 and another 8% between 2030 and 2050.

Like air-to-water heat pumps, the reduction is expected to be greater for larger buildings. The equipment for the heat pump is expected to see a cost reduction of 15% in the period 2020-30 and again in the period 2030-50, while the equipment for the gas boiler is only expected to decrease 0.5% annually. This gives an overall equipment cost reduction of 14% by 2030.

The largest decrease is expected for the installation costs, because the overall competencies among installers of air-to-water heat pumps has a large potential for improvement. The experience with hybrid systems is also expected to increase.

Similar to air-to-water heat pumps, the installation costs in households are expected to decrease by 25% in existing buildings and 15% in new single-family households. The installation is more expensive than for a pure air-to-water heat pump system, since a gas boiler also needs to be installed. For integrated solutions, the installation cost may be closer to that of a pure heat pump system. For both new and existing building complexes, the installation costs are expected to decrease by 25%.

### *- Performance*

When installed in a hybrid context, it is expected that the boiler will achieve lower total efficiency compared to the same gas boiler alone. This is due to the fact that a boiler in a hybrid context generally produces heat when higher water temperatures are required, ie. during cold periods and domestic water. According to a study performed by DGC, the efficiency of a gas boiler during the summer season is estimated as 91%<sup>11</sup> and a similar efficiency is expected for a boiler in a hybrid solution [5].

The heat pump efficiency is highly dependent on the specific conditions and the operation strategy. There are no in-depth analyses or studies of how much the heat pump efficiency improves in a hybrid set-up compared to a non-hybrid set-up, but it will be higher. Due to the lack of sources, the average heat pump efficiency is therefore constructed based on knowledge from pure heat pump solutions.

If it is assumed that the heat pump provides the full heat demand while the gas boiler provides the full domestic hot water demand, the heat pump's annual average efficiency is estimated to increase by 6-8%, for an existing household with radiators. This is not a completely accurate representation, because in reality, the heat pump and boiler will support each other more dynamically. For example, this calculation does not take into account that the heat pump in a hybrid context will not produce the full heat demand in the coldest periods.

Therefore, it is expected that the average annual efficiency of the heat pump will be increased further. To account for this, it is assumed that the heat pump will not produce during the 300 lowest COP-hours<sup>12</sup> (assuming same COP (2.2) as for producing domestic hot water), where the gas boiler provides the full heat demand instead. This increases the annual average efficiency of the heat pump by 10-13% compared to a pure air-to-water solution in an existing single-family home with radiators. This is under the assumption that when the heat pump assists the boiler with domestic hot water production, it only pre-heats the water to a degree where it does not affect the annual average efficiency of the heat pump. This value is very uncertain,

---

<sup>11</sup> Net Calorific Value (NCV)

<sup>12</sup> Estimated number of hours with average of 0 degrees or less in Denmark.

and there will also be variation between systems, due to differences in the buildings, system configuration and operating strategy.

### Uncertainty

The political environment has a large effect on the future of hybrid heat pumps. Currently, the focus is on pure heat pump solutions and looking at a future with less gas used for heating buildings. The lack of focus on gas-hybrid solutions is partly due to the political targets of reducing the use of fossil gas, and that the available amount of green gas in the future is uncertain. Therefore, other sectors, without relevant alternatives to gas, may be prioritized for this resource [7]. Consequently, it is uncertain if and when the sale of hybrid heat pumps will increase in Denmark.

On the other hand, it is unclear how the load on the power system will develop. The integration of large numbers of pure heat pump solutions and electrical vehicles can strain local power systems, which may increase the interest in hybrid solutions in such areas.

It is uncertain how the available models will develop, and which types will be most in demand. The price of gas versus the price of electricity, as well as the taxation structure, can also affect whether consumers choose a hybrid solution, a pure heat pump solution or a purely gas-based solution.

Therefore, the development of costs and efficiencies are uncertain.

As described in the chapter for heat pumps, their efficiencies are also uncertain, and more so for heat pumps in hybrid solutions, because the operating strategy also plays a role.

### Economy of scale effects

Due to the economy of scale effects of air-to-water heat pumps, hybrid heat pumps will also have a considerable cost reduction with increasing system size. This effect is expected to be less than that of pure air-to-water systems, since the gas boiler component does not have a significant economy of scale effect.

### Additional remarks

A key point regarding application of the data sheet is that the efficiency may vary considerably depending on the specific temperature parameters.

Application of the data sheet for calculations of a concrete project should be evaluated according to the specific local conditions. Some guidelines based on experience from existing applications of heat pumps are provided in the data sheets.

## Quantitative description

See separate Excel file for Data sheets.

## References

- [1] "Udskiftning af ældre gaskedel til gashybridvarmepumpe", Videnscenter for Energibesparelser i Bygninger, 2019, [https://www.byggeriogenergi.dk/media/2001/gashybridvarmepumpe\\_ok.pdf](https://www.byggeriogenergi.dk/media/2001/gashybridvarmepumpe_ok.pdf)
- [2] [www.Hybridvarme.nu](http://www.Hybridvarme.nu)
- [3] <https://starvvsenergi.dk/hybridvarmepumper/>
- [4] <https://www.gastech.dk/luft-til-vand-varmepumper/hybridloesning-varmepumpe-gasfyr/>
- [5] DGC, "Dokumentation for villagaskedlers faktiske virkningsgrad", November 2020.

- [6] Workshop about hybrid heat pumps organized by TEKNIQ, September 2020.
- [7] Danish Energy Agency, "Spørgsmål 263", march 2020.  
<https://www.ft.dk/samling/20191/almdel/kef/spm/263/svar/1643963/2165926.pdf>
- [8] Interviews with installation companies.
- [9] <https://hybridheatingeurope.eu/>

## 215 Solar heating system

### Contact information

Danish Energy Agency: Filip Gamborg, [fgb@ens.dk](mailto:fgb@ens.dk), Martin Rasmussen, [mra@ens.dk](mailto:mra@ens.dk)

Author: Original chapter from 2016 made by COWI. Update in 2021 by Ea Energy Analyses.

### Publication date

2016

### Amendments after publication date

Date	Ref.	Description
20-01-2021		Comprehensive update has been undertaken during Q4 of 2020. Primary focus is on data sheets, but text has been revised as well.

## Qualitative description

### Brief technology description

Solar energy for domestic hot water and space heating is usually based on the principle of pumping a heat transfer liquid (typically a mixture of water and propylene glycol) from an array of roof mounted solar collectors to one or more storage tanks. Solar heating for dwellings has mainly been developed for coverage of the entire hot water demand during the summer period, and to a minor degree for space heating [1]. Because of the mismatch between demand for space heating and available solar heat, there is a need of seasonal energy storage if solar energy should be the only supply. Such storage systems are only feasible at very large scale, and therefore solar heating for single-family houses must be combined with other heating systems, e.g. gas boilers or heat pumps. Small-scale long-term storages based on heat of fusion (heat of melting – the heat used when a substance melts) are theoretically possible, but they are not on the market today. Main components: Flat plate or vacuum tube solar collector, storage tank with heat exchangers, pump and control unit. Self-circulating systems work without pump and control.

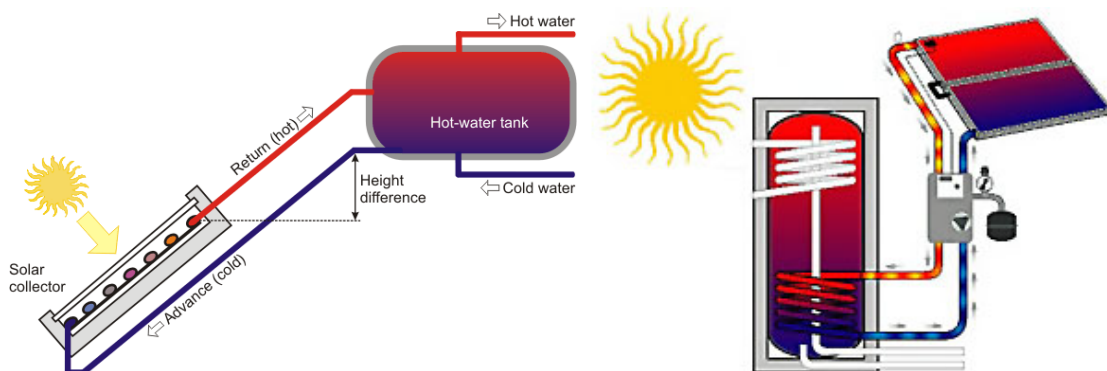

**Figure 49: Small solar heating system for domestic hot water. To the left a pumped system where auxiliary heat is supplied to the upper heat exchanger coil. To the right a thermosyphon system without pump. In such a system the circulation of the heat transfer fluid is driven by natural convection rather than a mechanical pump. By far the most systems are equipped with a pump.**

### Input

The primary energy input is solar radiation, of which a part can be converted to thermal energy in the absorber plate. The amount of energy reaching the solar collector depends on geographical site and orientation of the collector as well as possible shadows and ground reflectance. The only non-solar energy input to a solar heating system is the electric energy needed for the pump, controller and optional electric back-up heater. This amounts to up to 5 % of the delivered energy in a typical system, not including electric backup heater.

### Output

The output is thermal energy at medium temperature, typically 20-80 °C, depending on operation conditions and collector type. Higher temperatures are possible with special double-glazed solar collectors for district or industrial heating, but they are hardly relevant for domestic hot water (DHW) and space heating. In combination with heat pumps, it is possible to use very simple and inexpensive solar collectors operating at low temperature. These are typically made of polymers without any cover or insulation. It is very important to mention that the actual performance of a solar heating system is highly dependent on the energy consumption and its distribution on time. A high consumption per m<sup>2</sup> collector is favorable for the efficiency, because it tends to lower the operational temperature, but it also results in a low solar fraction i.e. the part of the heating demand that is covered by the solar heating system.

### Typical capacities

Traditionally, the system size is given in m<sup>2</sup> collector surface. For single-family homes the typical range is from 4 m<sup>2</sup> in case of a small DHW system to 15 m<sup>2</sup> for a combined space heating and DHW system. In order to compare with other technologies, IEA has estimated that 0.7 kW of nominal thermal power can be used as an equivalent to 1 m<sup>2</sup> collector surface [5][7].

### Regulation ability

The thermal effect is largely determined by the solar irradiance and the actual operating temperature relative to ambient temperature. As the temperature increases, efficiency drops, so in a sense solar collectors are self-regulating and will stop producing heat when it reaches the so-called stagnation temperature. The regulation system in a solar heating plant can switch the available solar energy to be used for hot water or space heating and in some cases to a heat dump (typically the ground circuit in a solar/heat pump combi-system), in order to avoid boiling or temperature-induced damages. Boiling can happen in case of a power failure during periods with bright sunshine. A safety valve will open and it will be necessary to refill the system.

### Advantages/disadvantages

#### *Advantages*

- No pollution during operation.
- The solar collector can be integrated in the urban environment and will then substitute a part of the building envelope.
- Large energy savings are often possible if the existing heater can be completely switched off during the summer so that standby losses can be substantially reduced.
- No dependency on fuels

#### *Disadvantages*

- Relatively expensive installation, except for large systems.
- Mismatch between heating demand and solar availability.
- Requires sufficient area on the roof with appropriate orientation.
- May compete with photovoltaic systems for the same area.

### Environment

A solar heating system mainly contains metals and glass that require energy in manufacturing. It is estimated that the energy payback time is 1-3 years [4] for a well-functioning system in Denmark. Almost all the materials can be recycled. The special selective surface used on most solar collectors is made in a chemical process that in some cases involves chromium. It is important that the process control is adequate to avoid any pollution from this process. The fluid used in most solar heating systems shall be disposed as low-toxic chemical waste.

How much fossil fuel a system will deplete, is dependent on the amount of heat the system provides. An LCA (Life Cycle Assessment) found that the main part of pollution in the life of a solar heating system is acidification by sulfur produced in combustion processes during production. These emissions accommodate half of the pollution from the system [5][6].

### Research and development perspectives

The most relevant R&D needed for further development of solar thermal systems is:

- Advanced and cost-effective storage systems for thermal energy.
- More cost-effective solar collectors, mainly through improved low-cost manufacturing processes.
- Self-adjusting control systems that is easily adapted to the existing heating system.
- Completely new system designs, e.g. air-based wall solar collectors combined with heat pump.
- Improved architectural design and smooth integration in buildings.
- Integration with solar photovoltaic and heat pumps (PVT – Thermal PV).
- Cost-effective mounting and installation methods

### Examples of market standard technology

The sector is characterized by step-by-step improvements, and areas where there have been improvements within the last 5 years are:

- Vacuum tube collectors with high power/cost ratio
- Hot water heat exchanger modules for Legionella prevention.
- Large-scale solar collectors for district heating and other applications.
- Energy saving pumps for less electricity consumption.

Most systems on the market today are vacuum tube collector modules and are systems with a pump circulating the liquid in the tubes. Most systems are modular, meaning it is possible to add another panel to existing systems. To cover 65% of the hot tap water demand in a system for a new apartment complex described earlier in this catalogue a solar collector area of approximately 300m<sup>2</sup> is needed, and such a system is not an “off the shelf” product. Two systems for individual houses are shown below:



Figure 50: Vacuum solar collector from Sun Power with 380W/m<sup>2</sup> capacity and a Solarterm hot water storage tank, 200L. [8]



Figure 51: Complete solar heating system with a hot water storage tank of 300L. Able to supply a new family house with 100% of hot water supply during hot months. [9]

### Prediction of performance and costs

Today, solar heating covers a minute part of the Danish energy supply (less than 1 % of the total heating), but the potential is enormous [2]. In recent years, the dominating market has shifted from individual systems to large-scale systems for district heating due to economy of scale benefits. However, with the increasing demand for energy efficiency of new buildings, individual solar heating plants could become more and more common. The international (European) solar thermal industry was growing rather quickly up to 2008 but has been decreasing since then. It has probably to do with the fact that solar photovoltaic has been growing very quickly in the past years. The major challenge for solar thermal energy is to develop low cost manufacturing and installation processes, which is very difficult in a situation where the markets in Europa and Denmark are declining [3]. A logical way to cope with this challenge is to merge solar thermal with solar photovoltaic into one system or module. There are also many attempts in this respect presently. It should be noticed that compact self-circulating DHW systems are far cheaper than the traditional pumped systems but are not much used in Denmark for aesthetical reasons and risk of freezing. If the cost of solar collector systems or PVT systems does not decrease fast enough, the combination of PV and heat pump or electric boiler could become a competitive alternative to individual solar systems. Solar heating systems are a mature and commercial technology with a large deployment (a category 4 technology).

### Uncertainty

Small solar systems for DHW are a category 4 technology. It is expected that this technology will continue to develop on market conditions with gradually reduced prices and increased performance.

The future of larger systems for space heating is more uncertain. The competition about roof space with photovoltaic will be a challenge and it could therefor happen that pure solar heating plants will continue to be a declining market.

### Economy of scale effects

The scale effect for solar heating systems for buildings mainly comes from installation costs that will be smaller per area for larger plants. The rational mounting or building integration has been the key issue to address for solar thermal heating systems.



### Additional remarks

This technology description is limited to traditional (pumped) solar heating systems without exchange of energy with other buildings than the one where the solar collectors are installed. Only domestic hot water and space heating are considered, not solar cooling.

### Quantitative description

See separate Excel file for Data sheets.

### References

- [1] Solvarme faktablade, [www.altomsolvarme.dk](http://www.altomsolvarme.dk).
- [2] [http://www.rhc-platform.org/fileadmin/user\\_upload/Structure/Solar\\_Thermal/Download/Solar\\_Thermal\\_Roadmap.pdf](http://www.rhc-platform.org/fileadmin/user_upload/Structure/Solar_Thermal/Download/Solar_Thermal_Roadmap.pdf)
- [3] <http://www.iea-shc.org/data/sites/1/publications/Solar-Heat-Worldwide-2014.pdf>
- [4] Energiteknologier – tekniske og økonomiske udviklingsperspektiver, Teknisk baggrundsrapport til Energistrategi 2025, 2005.
- [5] Life cycle environmental impact assessment of a solar water heater. Koroneos j. Christopher. 2012.
- [6] Bygningsintegreret energiproduktion. Det økologiske råd, juni 2011.
- [7] Recommendation: Converting solar thermal collector area into installed capacity (m<sup>2</sup> to kWth). Technical note, IEA SHC 2004.
- [8] Vvs-eksperten.dk. <https://www.vvs-eksperten.dk/varme-og-klima-solenergi-solfangersaet-solfangersaet-18-ror-og-200-liter-solvarmebeholder-379997530>. 2020 , Dbvvs.dk. <https://www.dbvvs.dk/shop/solvarmeanlaeg-pakke-4-2437p.html>. 2020
- [9] <https://www.dbvvs.dk/shop/solvarmeanlaeg-pakke-3-2433p.html>

## 216 Electric heating

### Contact information

Danish Energy Agency: Filip Gamborg, [fgb@ens.dk](mailto:fgb@ens.dk), Martin Rasmussen, [mra@ens.dk](mailto:mra@ens.dk)

Author: Original chapter from 2016 made by COWI. Update in 2021 by Ea Energy Analyses.

### Publication date

2016

### Amendments after publication date

Date	Ref.	Description
20-01-2021		Comprehensive update has been undertaken during Q4 of 2020. Primary focus is on data sheets, but text has been revised as well.

## Qualitative description

### Brief technology description

Electric radiators are mounted in each room. The bathrooms are sometimes equipped with electric floor heating systems. The hot tap water is made by a hot water tank with an electric heating coil. In case the distance to a secondary tapping point is large, more than one water heater can be installed. The radiators are equipped with internal thermostats, but more advanced systems are available, making it possible to program a temperature schedule individually for each room[1]. Electric heating can be a supplement or a complete system. Electric heating can be controlled by external systems, as an example Lauritz Knudsens IHC system including night set back. Also remote internet control is becoming popular, particular in vacation houses. The installation will normally include a group switch per one or two rooms, making central control very simple to install.

### Input

The input is electricity.

### Output

The output is room heating and hot water.

### Typical capacities

Typical capacities for one-family buildings and apartment complex are 5 to 400 kW.

### Regulation ability

The control is very flexible and the capacity can be regulated fast from 0 to 100 % and vice versa. It should be noted that the heat output is only dependent on the installed nominal power. In most cases, use of night setback or other forms of periodic heating is very efficient, as the reheating of the rooms can be very rapid. Furthermore, adding extra capacity is cheap.

Electric radiators can be built as storage heaters with some energy storage. For such radiators, electricity can be turned off for a period but heat is still emitted from the radiator. This ability can be used to e.g. fit time varying electricity tariffs in future.

### Advantages/disadvantages

#### *Advantages*

- Low investment and installation costs [4]
- Very high flexibility
- Very efficient reheating after night setback
- Very precise room temperature control
- Easy possibility of remote control
- Periodic sanitation of the hot tap water is done by heating the water in the hot water tank without any loss of energy.
- Furthermore, distribution heat losses are saved compared to water based heating systems.
- It is expected that electricity will become increasingly important in the future energy supply. With increasing penetration of renewable electricity, the ability to consume electricity flexible becomes increasingly interesting. Large scale demonstration of smart grid technologies on Bornholm has demonstrated that households with direct electric heating are more flexible than households with heat pumps [5].

#### *Disadvantages*

- High energy price
- High loss of exergy when converting electricity to heat
- If widespread used, the peak load power demand can prove a challenge for both power production units and the electricity grid.
- A household or indeed an apartment complex heated by electric heating often requires reinforcement of the electricity connection compared to households heated by boilers or district heating

### Environment

The environmental impact due to the use of electricity will depend on the way the electricity is produced.

### Research and development perspectives

Research concerning the future use of direct electrical heating in a smart grid may lead to positive results for this technology. It shall be taken into account that electrical heating historically often showed unexpected low energy consumptions [2]

### Examples of market standard technology

A modern electric heating system is an intelligent system, see [3]. Each room can be controlled individually, and the consumption per room can be displayed for the consumer. The bathrooms are heated with floor heating and the rooms with panels. The hot water tank is a 'smart tank' including self-learning controls to maintain the lowest average temperature, while still controlling the risk of Legionella. Storage heaters are used in case of varying electricity tariffs.

The technology itself is a mature technology, and have been used for many years, but one new development that have happened in recent years are that some of the electric radiators are now connected to the internet, which gives the consumer the possibility to turn it on and off from their phone from a distance.



Figure 52: Adax radiator with wi-fi connection, 250-2000W. [6]



Figure 54: Bosch 4500T hot water electric heater, 150l. [7]



Figure 53: DEVI heat mat for electric floor heating, 150W/m<sup>2</sup> [8]

### Prediction of performance and costs

The deployment of electric heating systems is expected to be limited to housings where the demand of space heating is considerably reduced, such as vacation houses, where water-based heating systems are too costly.

Electric heating systems are a mature and commercial technology with a large deployment (a category 4 technology).

### Uncertainty

With increasing focus on energy efficiency the future of direct electric heating solutions may be extremely limited.

### Economy of scale effects

Investment cost is very low and economy of scale is not relevant / not existing.

### Additional remarks

The prices below include a complete system for space heating and domestic hot water in each living unit.

## Quantitative description

See separate Excel file for Data sheets.

### References

- [1] [http://www.dimplex.co.uk/products/domestic\\_heating/installed\\_heating/storage\\_heaters/index.htm](http://www.dimplex.co.uk/products/domestic_heating/installed_heating/storage_heaters/index.htm).
- [2] Dansk Elforsyningsstatistik 2008.
- [3] <http://www.lk.dk/Lauritz+Knudsen/privat/det-intelligente-hjem/det-intelligente-hjem.page>
- [4] Peter Strøm from "EL-Strøm A/S", personal communication.
- [5] EcoGrid EU <http://www.eu-ecogrid.net/>
- [6] Greenline.dk. <https://www.greenline.dk/elartikler/elradiator/adax-wi-fi-elradiator>. 2020.
- [7] Bosch. <https://www.completvvs.dk/bosch-tronic-4500t-150-el-vandvarmer-med-elektronisk-display/>. 2020

- [8] Lavprisel.dk. [https://www.lavprisel.dk/devi-varmemaatte-dtif-150-900w-05x12-m-6-m2-med-foeleroer-47439?gclid=CjwKCAjw0On8BRAGeiwAincshDWeyiwBmGrRXw9f3owYG1t8FhX87BPmIYYnA8ObrHwnyQjW7BPZrxoC0kEQAvD\\_BwE](https://www.lavprisel.dk/devi-varmemaatte-dtif-150-900w-05x12-m-6-m2-med-foeleroer-47439?gclid=CjwKCAjw0On8BRAGeiwAincshDWeyiwBmGrRXw9f3owYG1t8FhX87BPmIYYnA8ObrHwnyQjW7BPZrxoC0kEQAvD_BwE). 2020.