



# Technology Data

## Carbon capture, transport and storage



Energistyrelsen  
Danish Energy Agency

Technology descriptions  
and projections for long-term  
energy system planning

### Technology Data – Carbon Capture, Transport and Storage

First published November 2021 by the Danish Energy Agency and Energinet,  
E-mail: [teknologikatalog@ens.dk](mailto:teknologikatalog@ens.dk), Internet: <http://www.ens.dk/teknologikatalog>  
Production: Danish Energy Agency and Energinet  
Front page design: Filip Gamborg  
Front cover photo: Colourbox.dk  
Number: 0002

This work is licensed under [Attribution 4.0 International](https://creativecommons.org/licenses/by/4.0/) 

## Amendment sheet

### Publication date

Publication date for this catalogue is November 2021 and merges existing chapters around Carbon Capture, Transport and Storage of some of the other published Technology Catalogues. The catalogue will be updated continuously as technologies evolve if the data changes significantly, errors are found or the need for descriptions of new technologies arise.

The newest version of the catalogue will always be available from the Danish Energy Agency's web site.

### Amendments after publication date

All updates made after the publication date will be listed in the amendment sheet below.

Version	Date	Ref.	Description
0001	November 2021		First published
0002	November 2023		Updated chapters on capture and pipeline transport, and added new chapters on liquefaction of CO <sub>2</sub> from biogas and intermediate storage.

## Preface

The *Danish Energy Agency* publish catalogues containing data on technologies for Energy Plants. All updates will be listed in the amendment sheet and in connection with the relevant chapters, and it will always be possible to find the most recently updated version on the Danish Energy Agency's website.

The primary objective of publishing technology catalogues is to establish a uniform, commonly accepted and up-to-date basis for energy planning activities, such as future outlooks, evaluations of security of supply and environmental impacts, climate change evaluations, as well as technical and economic analyses, e.g. on the framework conditions for the development and deployment of certain classes of technologies.

With this scope in mind, it is not the target of the technology data catalogues to provide an exhaustive collection of specifications on all available incarnations of energy technologies. Only selected, representative technologies are included to enable generic comparisons of technologies with similar functions in the energy system, e.g. thermal gasification *versus* combustion of biomass, or electricity storage in batteries *versus* flywheels.

Finally, the catalogue is meant for international as well as Danish audiences to support and contribute to similar initiatives aimed at forming a public and concerted knowledge base for international analyses and negotiations.

### Data sources and results

A guiding principle for developing the catalogue has been to rely primarily on well-documented and public information, with invited expert advice being secondary. Where unambiguous data could not be obtained, educated guesses or projections from experts are used. This is done to ensure consistency in estimates that would otherwise vary between users of the catalogue.

Cross-cutting comparisons between technologies will reveal inconsistencies which may have several causes:

- Technologies may be established under different conditions. As an example, the costs of offshore wind farms might be established based on data from ten projects. One of these might be an R&D project with floating turbines, some might be demonstration projects, and the cheapest may not include grid connections, etc. Such a situation will result in inconsistent cost estimates in cases where these differences may be unclear.
- Investors may have different views on economic attractiveness and different preferences. Some decisions may not be based on mere cost-benefit analyses, as some might tender for a good architect to design their building, while others will buy the cheapest building.

- Environmental regulations vary between countries, and the environment-related parts of the investment costs are often not reported separately.
- Expectations for the future economic trends, penetration of certain technologies, prices on energy and raw materials vary, which may cause differences in estimates.
- Reference documents are from different years. The ambition of the present publication has been to reduce the level of inconsistency to a minimum without compromising the fact that the real world is ambiguous. When different publications have presented different data, the publication which appears most in compliance with other publications has been selected as reference.

In order to handle the abovementioned uncertainties, each catalogue contains an introductory chapter, stating the guidelines for how data have been collected, estimated and presented. These guidelines are not perfect, but they represent the best balance between various considerations of data quality, availability, and usability.

### Danish preface

Energistyrelsen udarbejder teknologibeskrivelser for en række el- og varmeproduktionsteknologier. Alle opdateringer vil registreres i rettelsesbladet først i kataloget, og det vil altid være muligt at finde den seneste opdaterede version på Energistyrelsens hjemmeside.

Hovedformålet med teknologikataloget er at sikre et ensartet, alment accepteret og aktuelt grundlag for planlægningsarbejde og vurderinger af forsyningssikkerhed, beredskab, miljø og markedsudvikling hos bl.a. de systemansvarlige selskaber, universiteterne, rådgivere og Energistyrelsen. Dette omfatter for eksempel fremskrivninger, scenarieanalyser og teknisk-økonomiske analyser.

Desuden er teknologikataloget et nyttigt redskab til at vurdere udviklingsmulighederne for energisektorens mange teknologier til brug for tilrettelæggelsen af støtteprogrammer for energiforskning og -udvikling. Tilsvarende afspejler kataloget resultaterne af den energirelaterede forskning og udvikling. Også behovet for planlægning og vurdering af klimaprojekter har aktualiseret nødvendigheden af et opdateret databeredskab.

Endeligt kan teknologikataloget anvendes i såvel nordisk som internationalt perspektiv. Det kan derudover bruges som et led i en systematisk international vidensopbygning og -udveksling, ligesom kataloget kan benyttes som dansk udspil til teknologiske forudsætninger for internationale analyser og forhandlinger. Af disse grunde er kataloget udarbejdet på engelsk.



## Table of Contents

Introduction .....	6
Introduction to Carbon Capture Technologies .....	16
401 Amine post combustion carbon capture technology .....	30
402 Oxy-fuel combustion technology .....	53
403 Direct Air Capture (DAC) .....	76
Introduction to CO <sub>2</sub> transport.....	96
411 Liquefaction .....	109
412 Intermediate storage of CO <sub>2</sub> .....	119
421 CO <sub>2</sub> transport in pipelines .....	126
422 CO <sub>2</sub> transport by ship .....	135
423 CO <sub>2</sub> transport by road .....	142
Introduction to CO <sub>2</sub> storage.....	146
451 CO <sub>2</sub> storage .....	148

### Introduction

This section describes the basis for the technology catalogue on carbon capture, transport and storage, which is based on the guidelines for energy technology data for industrial process heat, version April 2020 (Energinet and the Danish Energy Agency), which in itself is based on the guideline for energy technology data for generation of electricity and district heating, version August 2016 (Energinet and the Danish Energy Agency).

The preparation of a technology catalogue for carbon capture, transport and storage is to an extent similar to other technology catalogues prepared by the Danish Energy Agency, however, certain principles and aspects of technology usage require descriptions of varying levels of detail.

This catalogue for carbon capture, transport and storage comprises most of the sections that are in the guideline for generation of electricity and district heating, but some of the descriptions differ slightly to make them applicable for describing technology for carbon capture, transport and storage.

The main purpose of the catalogue is to provide generalized data for analysis of energy systems related to carbon capture, transport and storage including economic scenario models and inputs for high-level energy planning.

This catalogue covers data regarding energy technologies designed for carbon capture, transport and storage, mainly for technologies that are relevant for the Danish industry.

The technology catalogue for carbon capture, transport and storage is intended as a separate catalogue in the series of the catalogues *Technology Data for Energy Plants*, which have been developed and maintained by the Danish Energy Agency, thus in general it follows the same structure and data format as the catalogue for generation of electricity and district heating.

This catalogue covers data regarding plants/technologies designed for carbon capture related to heat and power and cement plants, as well as transport and storage of carbon dioxide. This updated edition (2023) elaborates on the post-combustion, pre-combustion and oxy-fuel combustion chapters available in the previous edition (2020), with the addition of a developed chapter on Direct Air Capture (DAC) technologies and processes relevant for capturing CO<sub>2</sub> and/or reducing the CO<sub>2</sub> content in the atmosphere. In terms of carbon transport, the focus is liquefaction and intermediate storage from biogas plants and on CO<sub>2</sub> transport via pipeline, ship, and road. Finally, in terms of carbon storage, the focus is on onshore and nearshore CO<sub>2</sub> storage in saline aquifers and offshore CO<sub>2</sub> storage in depleted oil and gas fields.

The technology chapters for carbon capture were previously a part of the *Technology data for industrial process heat technologies*, accompanied by a supplemental guideline that only featured the sections and assumptions that differed from the *Technology Catalogue for industrial process heat technologies*. The guideline can now be found in its entirety below with a description of all relevant sections. The technology chapters for CO<sub>2</sub> transport were previously a part of the *Technology data for energy transport* with a separate introductory chapter to that part of the catalogue. This introductory chapter is found directly above the chapters regarding CO<sub>2</sub> transport. The technology chapter on CO<sub>2</sub> storage was not published within the *Technology data* domain before and was finalized during the restructuring of the present carbon capture technology chapters.

First, services and boundaries are defined, then guidelines for the sections corresponding to the sections in the main guidelines of the *Technology Data Catalogues* are given. These sections include general assumptions and both qualitative and quantitative parts of the catalogue. Templates for the data sheets are included in annexes.

### Qualitative description

The qualitative description describes the key characteristics of the technology as concisely as possible. The following paragraphs are included where relevant for the technology.

### Contact information

Containing the following information:

- Contact information: Contact details in case the reader has clarifying questions to the technology chapters. This could be the Danish Energy Agency, Energinet or the author of the technology chapters.
- Author: Entity/person responsible for preparing the technology chapter

### Brief technology description

Brief description for non-engineers of how the technology works and for which purpose.

An illustration of the technology is included, showing the main components and working principles.

### Input

The flue/process gas and other main materials (e.g. amines in scrubber systems) and gasses (e.g. O<sub>2</sub> in oxy-fuel combustion) and energy consumed (e.g. electricity and/or heat) by the technology or facility. Moisture and CO<sub>2</sub> content of the flue gas and required temperature of the input heat is specified.

Auxiliary inputs, such as chemicals or enzymes assisting the process are mentioned and their contribution described, if considered relevant.

### Output

The outputs are the CO<sub>2</sub> capture percentage (i.e. CO<sub>2</sub> reduction in the exhaust gas), the CO<sub>2</sub> purity, as well as co-product or by-products, for example process heat. Pressure of the output gasses and temperature of the output heat is specified as well. Other non-energy outputs may be stated such as condensate from flue gas, if relevant.

### Energy balance

The energy balance shows the energy inputs and outputs for the technology, where an illustrative diagram is shown based on data for the currently available technology.

For process heat losses and the produced energy carrier, it is important to specify temperature and pressure conditions.

The first important assumption is that the energy content of all the fuels, both produced and consumed, is always expressed in terms of Lower Heating Value (LHV). Consequently, and because of the presence of some latent heat of vaporization, the energy balance may result in a difference between the total energy input and total energy output.

### Application potential

The application potential describes the cases in which the technology can be used, e.g. how a retrofit case of carbon capture to existing heat and power plants is designed, or how carbon capture is integrated into cement production plants.

### Typical capacities

The stated capacities are for a single unit capable of capturing carbon. If the range of capacities vary significantly the typical range is stated (also in the notes), and it is mentioned if the different capacity sizes are characteristic for e.g. a specific sector.

### Space requirement

Space requirement is primarily expressed in m<sup>2</sup>/t CO<sub>2</sub> output/h. The value refers to the area occupied by the facilities needed to capture carbon, including chemical storage tanks and substation. If additional area is required for further required facilities it is stated separately.

### Regulation ability

Regulation abilities includes the part-load characteristics, start-up time and how quickly a plant can adapt production when already online. The technologies will most often have the necessary regulation abilities.

### Advantages/ disadvantages

A description of specific advantages and disadvantages relative to equivalent technologies and delivering the same energy service. Generic advantages are ignored; e.g. renewable energy technologies mitigating climate risks and enhance security of supply.

### Environment

Specific environmental and resource depletion impacts are mentioned. For example, harmful emissions to air, soil or water; consumption of rare or toxic materials; consumption of large amount of water (in general and relative to other technologies delivering same service); issues with handling of waste and decommissioning etc.

### Research and development perspectives

This section lists the most important challenges to further development of the technology. Also, the potential for technological development in terms of costs and efficiency is mentioned and quantified if possible. Danish research and development perspectives are highlighted, where relevant.

### Examples of market standard technology

Recent full-scale commercial projects, which can be considered market standard, are mentioned, preferably with links. A description of what is meant by “market standard” is given in the introduction to the quantitative description section. For technologies where no market standard has yet been established, reference is made to best available technology in R&D projects.

### Prediction of performance and costs

Cost reductions and improvements of performance can be expected for most technologies in the future. This section accounts for the assumptions underlying the cost and performance in 2020 as well as the improvements assumed for the years 2030, 2040 and 2050.

The specific technology is identified and classified in one of four categories of technological maturity, indicating the commercial and technological progress, and the assumptions for the projections are described in detail.

In formulating the section, the following background information is considered:

#### (i) Data for 2020

In case of technologies where market standards have been established, performance and cost data of recent installed versions of the technology in Denmark or the most similar countries in relation to the specific technology in Northern Europe are projected to 2020 (FID) and used for the 2020 estimates.

If consistent data are not available, or if no suitable market standard has yet emerged for new technologies, the 2020 costs may be estimated using an engineering-based approach applying a decomposition of manufacturing and installation costs into raw materials, labor costs, financial costs, etc. International references such as the IEA, NREL etc. are preferred for such estimates.

#### (ii) Assumptions for the period 2020 to 2050

According to the IEA:

*“Innovation theory describes technological innovation through two approaches: the technology-push model, in which new technologies evolve and push themselves into the marketplace; and the market-pull model, in which a market opportunity leads to investment in R&D and, eventually, to an innovation” (ref. 6).*



The level of “market-pull” is to a high degree dependent on the global climate and energy policies. Hence, in a future with strong climate policies, demand for e.g. renewable energy technologies will be higher, whereby innovation is expected to take place faster than in a situation with less ambitious policies. This is expected to lead to both more efficient technologies, as well as cost reductions due to economy of scale effects. Therefore, for technologies where large cost reductions are expected, it is important to account for assumptions about global future demand.

The IEA’s New Policies Scenario provides the framework for the Danish Energy Agency’s projection of international fuel prices and CO<sub>2</sub>-prices and is also used in the preparation of this catalogue. Thus, the projections of the demand for technologies are defined in accordance with the thinking in the New Policies Scenario, described as follows:

*“New Policies Scenario: A scenario in the World Energy Outlook that takes account of broad policy commitments and plans that have been announced by countries, including national pledges to reduce greenhouse gas emissions and plans to phase out fossil energy subsidies, even if the measures to implement these commitments have yet to be identified or announced. This broadly serves as the IEA baseline scenario.” (ref. 7).*

Alternative projections may be presented as well relying, for example, on the IEA’s 450 Scenario (strong climate policies) or the IEA’s Current Policies Scenario (weaker climate policies), or more recent equivalent IEA scenarios.

### Learning curves and technological maturity

Predicting the future costs of technologies may be done by applying a cost decomposition strategy, as mentioned above, decomposing the costs of the technology into categories such as labor, materials, etc. for which predictions already exist. Alternatively, the development could be predicted using learning curves. Learning curves express the idea that each time a unit of a particular technology is produced, learning accumulates, which leads to cheaper production of the next unit of that technology. The learning rates also take into account benefits from economy of scale and benefits related to using automated production processes at high production volumes. The cost projections are based on the future generation capacity in IEA’s 2 DS and 4 DS scenarios (2017 values are assumed to be a good approximation for 2015) [3], or more recent equivalent IEA scenarios.

Learning rates typically vary between 5 and 25%. In 2015, Rubin et al published “A review of learning rates for electricity supply technologies” [4], which provides a comprehensive and up to date overview of learning rates for a range of relevant technologies, among which:

The potential for improving technologies is linked to the level of technological maturity. The technologies are categorized within one of the following four levels of technological maturity.

Category 1. Technologies that are still in the *research and development phase*. The uncertainty related to price and performance today and in the future is highly significant (e.g. wave energy converters, solid oxide fuel cells).

Category 2. Technologies in the *pioneer phase*. The technology has been proven to work through demonstration facilities or semi-commercial plants. Due to the limited application, the price and performance is still attached with high uncertainty since development and customization is still needed. The technology still has a significant development potential (e.g. gasification of biomass).

Category 3. *Commercial technologies with moderate deployment*. The price and performance of the technology today is well known. These technologies are deemed to have a certain development potential and therefore there is a considerable level of uncertainty related to future price and performance (e.g. offshore wind turbines).

Category 4. *Commercial technologies, with large deployment*. The price and performance of the technology today is well known, and normally only incremental improvements would be expected. Therefore, the future price and performance may also be projected with a relatively high level of certainty (e.g. coal power, gas turbine).

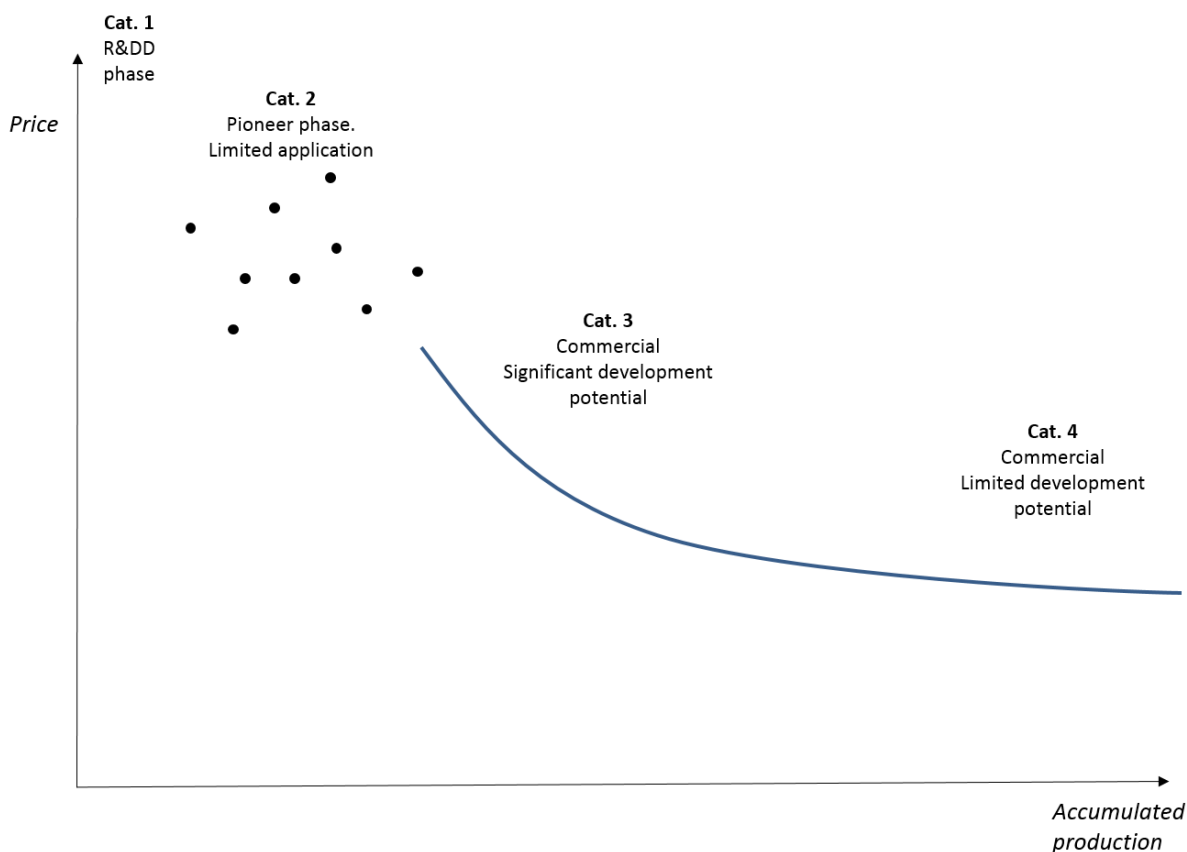

**Figure 1: Technological development phases. Correlation between accumulated production volume (MW) and price.**

### Uncertainty

The catalogue covers both mature technologies and technologies under development. This implies that the price and performance of some technologies may be estimated with a relatively high level of certainty whereas in the case of others, both cost and performance today as well as in the future are associated with high levels of uncertainty.

This section of the technology chapters explains the main challenges to precision of the data and identifies the areas on which the uncertainty ranges in the quantitative description are based. This includes technological or market related issues of the specific technology as well as the level of experience and knowledge in the sector and possible limitations on raw materials. The issues should also relate to the technological development maturity as discussed above.

The level of uncertainty is illustrated by providing a lower and higher bound beside the central estimate, which shall be interpreted as representing probabilities corresponding to a 90% confidence interval. It should be noted, that projecting costs of technologies far into the future is a task associated with very large uncertainties. Thus, depending on the technological maturity expressed and the period considered, the confidence interval may be very large. It is the case, for example, of less developed technologies (category 1 and 2) and longtime horizons (2050).

### Additional remarks

This section includes other information, for example links to web sites that describe the technology further or give key figures on it.

### References

References are numbered in the text in squared brackets and bibliographical details are listed in the end of the technology chapter prior to the data sheets, references for data in the data sheet are listed below the data sheet

for each sheet also in the Excel version. The format of biographical details of references should be; name of author, title of report, year of publication.

### Quantitative description

*For data sheets see the Excel file in the appendix*

To enable comparative analyses between different technologies it is imperative that data are actually comparable. All cost data are stated in fixed 2020 prices excluding value added taxes (VAT) and other taxes. The information given in the tables relate to the development status of the technology at the point of final investment decision (FID) in the given year (2020, 2030, 2040 and 2050). FID is assumed to be taken when financing of a project is secured, and all permits are at hand. The year of commissioning will depend on the construction time of the individual technologies.

A typical table of quantitative data is shown below, containing all parameters used to describe the specific technologies. The table consists of a generic part, which is identical for groups of similar technologies and a technology specific part, containing information, which is only relevant for the specific technology. The generic part is made to allow for easy comparison of technologies.

Each cell in the table contains only one number, which is the central estimate for the market standard technology, i.e. no range indications.

Uncertainties related to the figures are stated in the columns named *uncertainty*. To keep the table simple, the level of uncertainty is only specified for years 2025 and 2050.

The level of uncertainty is illustrated by providing a lower and higher bound. These are chosen to reflect the uncertainties of the best projections by the authors. The section on uncertainty in the qualitative description for each technology indicates the main issues influencing the uncertainty related to the specific technology. For technologies in the early stages of technological development or technologies especially prone to variations of cost and performance data, the bounds expressing the confidence interval could result in large intervals. The uncertainty only applies to the market standard technology; in other words, the uncertainty interval does not represent the product range (for example a product with lower efficiency at a lower price or vice versa).

The level of uncertainty is only stated for the most critical figures such as investment cost and efficiencies. Other figures are considered if relevant.

All data in the tables are referenced by a number in the utmost right column (Ref), referring to the source specified below the table. The following separators are used:

; (semicolon)	separation between the five time horizons (2020, 2025, 2030, 2040, 2050)
/ (forward slash)	separation between sources with different data
+ (plus)	agreement between sources on same data

Notes include additional information on how the data are obtained, as well as assumptions and potential calculations behind the figures presented are listed below the data sheet. References between notes and data are made by letters in the second utmost column in the data sheet. Before using the data, please be aware that essential information may be found in the notes below the table.

It is crucial that the data for the technology is not based on one special version of the technology of which there is only one plant in operation or only on supplier of the technology.

### Energy/technical data

#### Typical total plant size

The total CO<sub>2</sub> output per hour is used for describing the capacity, preferably a typical capacity. It is stated for a single plant or facility. In the case of substantial difference in performance or costs for different sizes of the technology, the technology may be specified in two or more separated data sheets. It should be stressed that data in the table is based on the typical capacity. When deviations from the typical capacity are made, economy of scale effects need to be considered inside the range of typical sizes (see the section about investment cost in the main catalogue). The capacity range should be stated in the notes.

#### Output

As with the mass and energy inputs, energy outputs are expressed as mass or energy per t CO<sub>2</sub> output. Pressure of the output gases and temperature of the output heat are specified as well.

Any energy co-product or by-product of the reaction must be specified within the outputs, including process heat loss. Since fuel inputs are measured at lower heating value, in some cases the total efficiency may exceed or be lower than 100%.

The process heat (output) is, if possible, separated in recoverable (for example for district heating purposes) and unrecoverable heat and the temperatures are specified.

#### Forced and planned outage

Forced outage is reduced production caused by unplanned outages. The weighted forced outage hours are the sum of hours of forced outage, weighted according to how much of full capacity was out. Forced outage is defined as the number of weighted forced outage hours divided by the sum of forced outage hours and operation hours. The weighted forced outage hours are the sum of hours of reduced production caused by unplanned outages, weighted according to how much capacity was out. Forced outage is given in percent, while planned outage (for example due to renovations) is given in weeks per year.

#### Technical lifetime

The technical lifetime is the expected time for which a carbon capture plant can be operated within, or acceptably close to its original performance specifications, provided that normal operation and maintenance takes place. During this lifetime, some performance parameters may degrade gradually but still stay within acceptable limits. For instance, efficiencies often decrease slightly (few percent) over the years, and O&M costs increase due to wear and degradation of components and systems. At the end of the technical lifetime, the frequency of unforeseen operational problems and risk of breakdowns is expected to lead to unacceptably low availability and/or high O&M costs. At this time, the plant is decommissioned or undergoes a lifetime extension, which implies a major renovation of components and systems as required to make the plant suitable for a new period of continued operation.

The technical lifetime stated in this catalogue is a theoretical value inherent to each technology, based on experience. As stated earlier, typical annual operation hours and the load profile is specific for each carbon capture technology. The expected technical lifetime takes into account a typical number of start-ups and shut-downs (an indication of the number of annual operation hours, start-ups and shut-downs is given in the Financial data description, under Start-up costs).

In real life, specific plants of similar technology may operate for shorter or longer times. The strategy for operation and maintenance, e.g. the number of operation hours, start-ups, and the reinvestments made over the years, will largely influence the actual lifetime.



### Construction time

Time from final investment decision (FID) until commissioning completed (start of commercial operation), expressed in years.

### Financial data

Financial data are all in Euro (€), fixed prices, at the 2020-level and exclude value added taxes (VAT) and other taxes, unless specified otherwise.

Several data originate in Danish references. For those data a fixed exchange ratio of 7.45 DKK per € has been used.

When data about costs is found in sources is shown in other price years, the Danish net price index shall be used when stating the costs at 2020 price level.

European data, with a particular focus on Danish sources, have been emphasized in developing this catalogue.

### Investment cost

The investment costs are also called the engineering, procurement and construction (EPC) price or the overnight cost. Infrastructure and connection costs, i.e. electricity, fuel and water connections inside the premises of a plant, are also included.

The investment cost is reported on a normalized basis, i.e. cost per capacity (t CO<sub>2</sub> output / hour). The specific investment cost is the total investment cost divided by the typical total plant size described in the quantitative section.

Where possible, the investment cost is divided on equipment cost and installation cost. Equipment cost covers the components and machinery including environmental facilities, whereas installation cost covers engineering, civil works, buildings, grid connection, installation and commissioning of equipment.

The rent of land is not included but may be assessed based on the space requirements, if specified in the qualitative description.

The owners' predevelopment costs (administration, consultancy, project management, site preparation, approvals by authorities) and interest during construction are not included. The costs to dismantle decommissioned plants are also not included. Decommissioning costs may be offset by the residual value of the assets.

### Contingency

Project owners often add a contingency to a project's capital cost estimate to deal with project overruns due to uncertainties and risks caused by uncertainties in the project definition. The Association for the Advancement of Cost Engineering International (AACE International) has defined contingency as *"An amount added to an estimate to allow for items, conditions, or events for which the state, occurrence, or effect is uncertain and that experience shows will likely result, in aggregate, in additional costs. Typically estimated using statistical analysis or judgment based on past asset or project experience."* AACE International further describes contingency as *"...planning and estimating errors and omissions.....design developments and changes within the scope, and variations in market and environmental conditions"*. The Technology Catalogues represent general techno-economic data for different technologies; and are not intended as basis for investment decisions. Therefore the data in the Technology Catalogues aim at not including contingency.

\*Source: AACE (2022) Cost engineering terminology (<https://library.aacei.org/terminology/welcome.shtml>).

### Cost of grid expansion

The costs for the connection of the plant to the system are included in the investment cost, while no cost of grid expansion or reinforcement is taken into account in the present data.

### Business cycles

Historic costs of energy equipment can show fluctuations that are related to business cycles. This was the case of the period 2007-2008 for example or more recently around 2021-2022, where prices costs of many energy generation technologies increased dramatically driven by rapid increases in global raw material costs and supply chain costs. The primary objective of the technology catalogues is to establish general representative techno-economic data for different technologies, which can form a basis for energy planning activities and technical and economic analyses. The catalogues do not attempt to reflect fluctuations in technology costs due to fluctuations in costs of labour and materials driven by e.g. global/regional crises or major events affecting short term supply or demand. The technology cost developments in the catalogues thus intend to reflect an average business cycle situation and macroeconomic environment in a general long-term equilibrium.

### Input

All inputs that contribute to the mass and energy balance are included as main input and are expressed mass per t CO<sub>2</sub> output and as molar/volume percentage in relation to the (flue or syn) gas input, or equivalently gas.

The energy inputs (and outputs) are always expressed in lower heating value (LHV) and moisture content considered is specified if relevant.

Auxiliary inputs, such as **chemicals** or **enzymes** that are assisting the process but do not contribute to the energy balance are included as *auxiliary products* (under *input*) and are expressed in kg/t CO<sub>2</sub> output.

### Economy of scale

The main idea of the catalogue is to provide technical and economic figures for specific sizes of certain technologies. Where technology sizes vary over a large range, different sizes are defined and separate technology chapters (or just datasheets) are developed.

For assessment of data for technology sizes not included in the catalogue, some general rules should be applied with caution to the scaling of industrial technologies.

The example below is for the energy plants but is assumed that the same principle can be applied for the CC technologies.

The cost of one unit for larger technologies is usually less than that for smaller technologies. This is called the 'economy of scale'. The basic equation (ref. 2) is:

$$\frac{C_1}{C_2} = \left(\frac{P_1}{P_2}\right)^a$$

Where: C<sub>1</sub> = Investment cost of technology 1 (e.g. in M€)

C<sub>2</sub> = Investment cost of technology 2

P<sub>1</sub> = Power generation capacity of technology 1 (e.g. in MW)

P<sub>2</sub> = Power generation capacity of technology 2

a = Proportionality factor

Usually, the proportionality factor is about 0.6 – 0.7 for power plants, but extended project schedules may cause the factor to increase. It is important, however, that the technologies are essentially identical in construction technique, design, and construction time frame and that the only significant difference is in size.

The relevant ranges where the economy of scale correction applies are stated in the notes for the capacity field of each technology table. The stated range shall at the same time represents typical capacity ranges.

### Operation and maintenance (O&M) costs.

The fixed share of O&M is calculated as cost per plant size (€ per t (CO<sub>2</sub> output/hour) per year), where the typical total plant size is the one defined at the beginning of this chapter and stated in the tables. It includes all costs, which are independent of how the plant is operated, e.g. administration, operational staff, payments for O&M service agreements, network use of system charges, property tax, and insurance. Any necessary reinvestments to keep the plant operating within the scheduled lifetime are also included, whereas reinvestments to extend the life beyond the lifetime are excluded. Reinvestments are discounted at 4 % annual discount rate in real terms. The cost of reinvestments to extend the lifetime of the plants may be mentioned in a note if the data has been readily available.

The variable O&M costs (€/t CO<sub>2</sub> output) include consumption of auxiliary materials (water, lubricants, fuel additives), treatment and disposal of residuals, spare parts and output related repair and maintenance (however not costs covered by guarantees and insurances).

Planned and unplanned maintenance costs may fall under fixed costs (e.g. scheduled yearly maintenance works) or variable costs (e.g. works depending on actual operating time) and are split accordingly.

All costs related to the process inputs (electricity, heat, fuel) are not included.

It should be noticed that O&M costs often develop over time. The stated O&M costs are therefore average costs during the entire lifetime.

### Start-up costs

The O&M costs stated in this catalogue includes start-up costs and takes into account a typical number of start-ups and shut-downs. Therefore, the start-up costs should not be specifically included in more general analyses. They should only be used in detailed dynamic analyses of the hour-by-hour load of the technology.

Start-up costs are stated in costs per t<sub>CO<sub>2</sub></sub>/h per start up (€ per startup/[t CO<sub>2</sub>/hour]), if relevant. They reflect the direct and indirect costs during a start-up and the subsequent shut down.

## Technology specific data

Additional data is specified in this section, depending on the technology.

### References

Reference documents are mentioned in each of the technology sheets and technology chapters. References used in the guideline supplement are given below:

[1] Peres, C.B.; Resende, P.M.R.; Nunes, L.J.R.; Morais, L.C.d. Advances in Carbon Capture and Use (CCU) Technologies: A Comprehensive Review and CO<sub>2</sub> Mitigation Potential Analysis. *Clean Technol.* 2022, 4, 1193-1207.

[2] Andrea Di Giuliano, Serena Capone, Michele Anatone, and Katia Gallucci *Industrial & Engineering Chemistry Research* 2022 61 (39), 14403-14432

[3] Eloy S. Sanz-Pérez, Christopher R. Murdock, Stephanie A. Didas, and Christopher W. Jones *Chemical Reviews* 2016 116 (19), 11840-11876

## Appendixes

The datasheets in the appendix are in a separate Excel file.

## Introduction to Carbon Capture Technologies

### Contact information

- Contact information: Danish Energy Agency: Emil Esketveit Rasmussen emrm@ens.dk; Christoph Wolter chwo@ens.dk
- Author: Mads Borgbjerg Jensen, Hazel Reardon and Mads Heuckendorff from COWI

### i.1 Abbreviations

Abbreviation	Definition
ASU	Air Separation Unit
ATEX	ATmospheres EXplosives
CC	Carbon capture
CCS	Carbon capture and storage
CHP	Combined Heat and Power
CPU	CO <sub>2</sub> Purification Unit
CFB	Circulating Fluidized Bed
DAC	Direct Air Capture
DH	District Heating
ECRA	European Cement Research Academy
FGR	Flue Gas Recirculation
MWh <sub>e</sub>	Mega Watt hour electric
ORC	Organic Rankine Cycle
PC	Pulverized Coal
PtX	Power to X

### Introduction

Carbon capture technologies (CC) are technologies that capture CO<sub>2</sub> from, e.g., processes related to combustion or upgrading of fossil fuels and bio-fuels, or from industrial chemical processes (*e.g.*, cement production) or absorb CO<sub>2</sub> directly from the air. Even as of today, CC technology is commercially available and used around the world, although it has yet to become economically feasible in the power and heat sector and in industry. The most common utilization of CC technologies today consists of a capture part, where CO<sub>2</sub>, methane and hydrogen are separated from pure natural gas. In Denmark today, the most common use of CC is for upgrading of biogas. (Upgrading of biogas is described in chapter 82 of the *Technology Data for renewable fuels*.) This catalogue includes descriptions of technologies that provide the CC service, transport and storage of carbon. The CC technologies can, however, be carried out using multiple types of systems. (See examples of types and further descriptions in **Fejl! Henvisningskilde ikke fundet..**)



Table 1: Description of CC technologies strength and weakness [1]

CC technology	Plant description	Advantages	Limitations
<b>Post-Combustion [1]</b>	CO <sub>2</sub> is removed from the flue gas through absorption by selective solvents. The most progressed processes are based on amine solvents.	Can be applied on existing technologies with a flue gas.	Energy intensive and costly post-separation methodology; requires direct connection to stationary plant.
<b>Pre-Combustion [1]</b>	The fuel is pre-treated and converted into a mix of CO <sub>2</sub> and hydrogen, from which CO <sub>2</sub> is separated. The hydrogen is then burned to produce power.	As the technology is not necessarily linked to a power plant, the hydrogen produced can be utilised in multiple sectors, e.g., transport.	High investment costs, energy intensive in both electricity usage and fuel conversion loss.
<b>Oxy-fuel combustion [1]</b>	The fuel is burned with oxygen instead of air, producing a flue stream of CO <sub>2</sub> and water vapour without nitrogen. From this stream, water is condensed and a stream of CO <sub>2</sub> is obtained. The oxygen required for the combustion is extracted in situ from air or isolated as a by-product from electrolysis.	The flue gas would primarily consist of CO <sub>2</sub> and H <sub>2</sub> O, which are easier and cheaper to separate compared to “normal” flue gas with large amounts of nitrogen.	Energy intensive and costly oxygen production; requires direct connection to stationary plant. Lower purity of captured CO <sub>2</sub> , therefore requiring more purification.
<b>Chemical Looping Combustion [2]</b>	A new combustion technology with inherent separation of CO <sub>2</sub> by transferring oxygen from the combustion air to the fuel using metal oxides. The flue gas from the combustion chamber consists of only CO <sub>2</sub> and H <sub>2</sub> O.	Potentially low costs and high efficiencies in both electricity and CC as the separation process happens internally during combustion.	Low on the development stage and has, for now, only been proven with gas as an input fuel; requires direct connection to stationary plant.
<b>Direct Air Capture [3]</b>	CO <sub>2</sub> is captured directly from the air. The technologies that are the most developed function through absorption by selective solvents and large air conductors. Pure CO <sub>2</sub> is released thereafter for subsequent processing for use in, e.g., e-fuel production or storage.	Does not require a CO <sub>2</sub> heavy flue gas and can therefore be located close to storage or e-fuel (Power-to-X) production.	Very energy intensive.

With the exception of the chemical looping combustion technology, all CC technologies rely on existing technologies combined in an innovative way and simplified representations of the processes are illustrated in Figure 2.

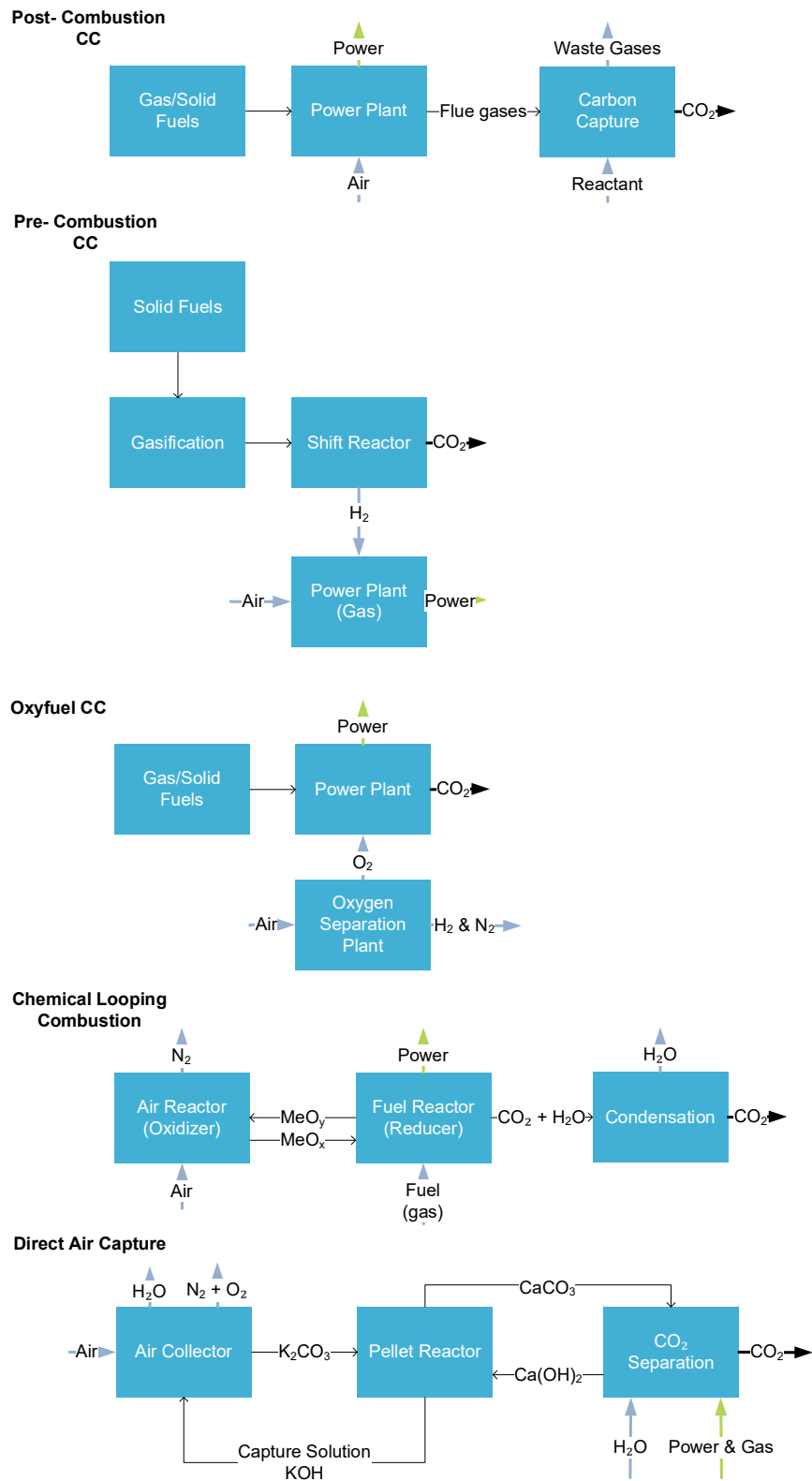

Figure 2: Simplified block flow diagrams of the various CC systems described herein.[1]

The first three system types resemble the more traditional power plant solutions and have been proven at a larger scale, while Chemical looping combustion is only at demonstration scale and could be seen as a special case of oxy-fuel combustion. Direct Air Capture (DAC), however, distinguishes itself significantly from the other four technologies, as its sole purpose is to capture CO<sub>2</sub> and not to limit the emissions from power and heat production.

This guideline will focus on how to describe the CC part of the first three technologies in a way that is useful when the purpose is to deliver technology data for technical energy system modelling.

A challenge is where to put the boundaries for the CC systems, but it is desirable that it is done in the same way for all the three CC systems categories. Therefore, the CC technology is described as a module. The module features the CC technology and specifies input and output. Thus, the power plant technologies or other technologies related to the CC technology is not described in this context.

Using this approach, the modeler has to provide technology data for technologies not included in the descriptions e.g., power plants using hydrogen as fuel, power plants using pure oxygen instead of air, thermal gasification plants, plants producing oxygen or prices for inputs (e.g., for O<sub>2</sub> or syngas).

In Figure 3, Figure 4 and Figure 5, the suggested boundaries for the CC processes are illustrated by the dotted lines.

For post combustion CC technologies (Figure 3), a CC technology is described. The inputs are flue gas, energy, and other auxiliary inputs. The reduced energy efficiency of the power plant with post combustion CC is accounted for by an energy input to the CC. The output is CO<sub>2</sub>, flue gas with lower CO<sub>2</sub> content and heat.

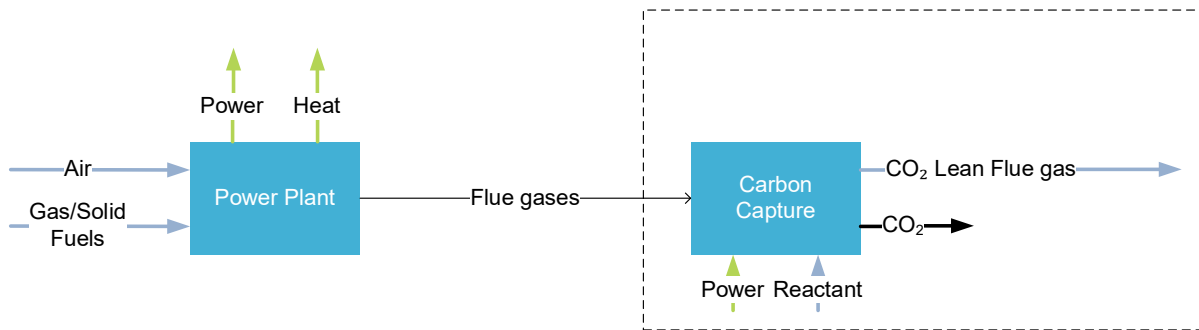

Figure 3: Post combustion

For pre-combustion CC technology (Figure 4), the shift reactor is described as the CC-technology. The inputs are syngas (from gasification of biomass), energy and other auxiliary inputs. The outputs, are CO<sub>2</sub>, H<sub>2</sub> and heat.

There will be no descriptions of the gasification plants nor of the power plant burning H<sub>2</sub>.

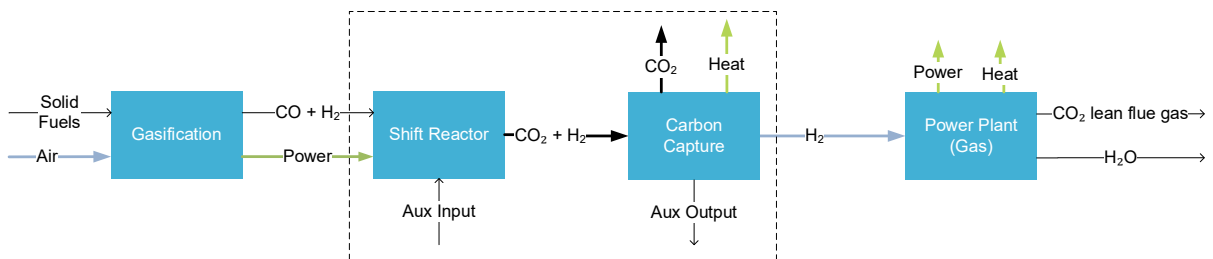

Figure 4: Pre-combustion

For oxy-fuel combustion CC technology (Figure 5) the CC process can be regarded as an add-on module that includes all the required modifications. Inputs are flue gas from oxy-fuel combustion (consisting of CO<sub>2</sub> and H<sub>2</sub>O), energy and other auxiliary inputs. The outputs are CO<sub>2</sub>, H<sub>2</sub>O and heat.

Oxy-fuel combustion processes can only produce modest purity CO<sub>2</sub> (~70-90%), hence a CO<sub>2</sub> post processing unit is required to upgrade the CO<sub>2</sub> to meet transportation or utilization conditions as shown in Figure 5. As a result of the relatively low quality of the raw CO<sub>2</sub>, the CO<sub>2</sub> processing unit will be more comprehensive compared to other CC technologies.

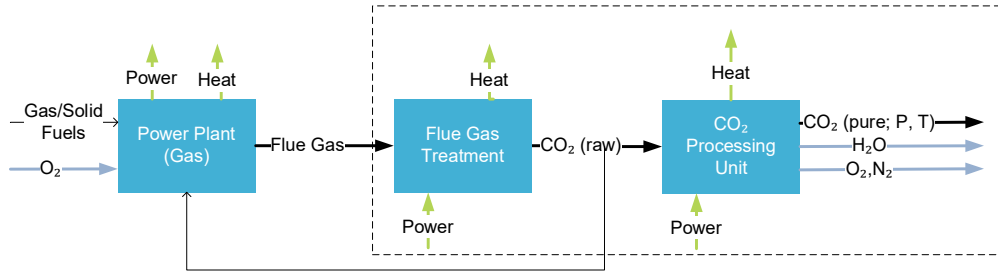

Figure 5: Oxy-fuel combustion

For direct air capture (DAC; Figure 6) the CO<sub>2</sub> is captured directly from the air, hence the DAC module will have no interfaces to existing plants. The module comprises the entire capture plant and all auxiliary systems needed by the specific technology. Inputs to the module are air, energy and possibly (dependent on the specific technology) various auxiliaries.

As with the other CC technologies, the DAC module will provide a concentrated low-pressure CO<sub>2</sub> stream, requiring a CO<sub>2</sub> post-treatment unit to upgrade the CO<sub>2</sub> to meet the quality requirements for transportation/utilization processes.

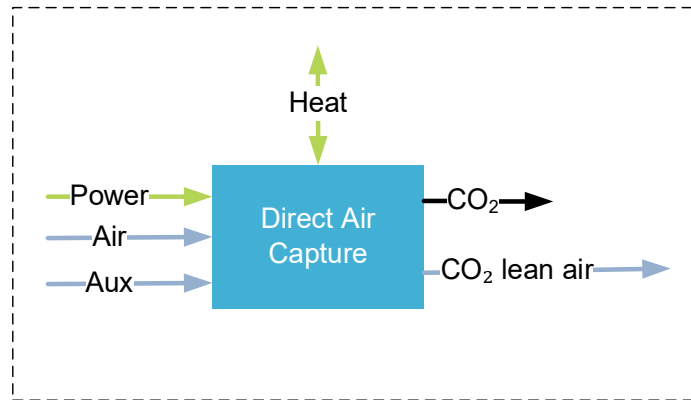

Figure 6. Illustration of Direct Air Capture (DAC).

All CC processes need to deliver the captured CO<sub>2</sub> at a certain quality and at certain physical conditions (e.g. compressed CO<sub>2</sub>), regardless whether the use is for geological storage or further utilisation. A CO<sub>2</sub> post processing unit (shown in Figure 7) will upgrade the CO<sub>2</sub> to required specification. Inputs to the post processing unit are raw CO<sub>2</sub> and electricity. Outputs are CO<sub>2</sub> (at required purity, pressure, and temperature), water, heat and possibly O<sub>2</sub>, N<sub>2</sub> and Ar.



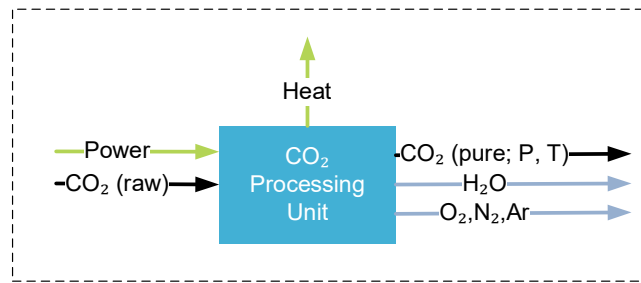

Figure 7. Illustration of CO<sub>2</sub> processing (conditioning) unit.

### General Assumptions

The data presented in this catalogue is based on some general assumptions, mainly relating to the utilization time, load and start-ups of plants and technologies.

CC technologies are assumed to be designed for continuous operation throughout the year, except for maintenance and outages, but their actual annual operation pattern will generally depend on the operation pattern of the technologies with which they are combined. Therefore, for the figures in this catalogue, a default assumed load pattern is as assumed for the technologies generating electricity and district heating. The assumed number of annual operation hours is shown in

Table 2. And the assumed number of start-ups for CC technologies are as shown in **Fejl! Henvisningskilde ikke fundet.**, unless otherwise stated. Any exception to these general assumptions is documented in the relative technology chapter with a specific note.

Table 2: Assumed number of full load hours for technologies producing electricity and heating; 75 % of generation is expected to take place in full load and the remaining 25 % in part load.

	Full load hours (electricity)	Full load hours (heat)
CHP back pressure units	4,000	4,000
CHP extraction units	5,000	4,000
Municipal solid waste / biogas stand alone	8,000	8,000

Table 3: Number of start-ups for CC-technologies are assumed to be the same for the power plant with which they are combined.

	Assumed number of start-ups per year
Coal CHP	15
Natural gas CHP (except gas engines)	30
Gas Engines	100
Wood pellet CHP	15
Heat only boilers	50
Municipal solid waste / biogas stand alone	5

## i.2 Carbon Capture Technologies

As described in the introduction, CC is a process that recovers CO<sub>2</sub> from a point source (e.g. flue gas) or from the atmosphere (DAC) and turns it into a concentrated CO<sub>2</sub> stream and a CO<sub>2</sub>-lean flue gas stream. The concentrated CO<sub>2</sub> stream can be used in various ways after conditioning, such as in the food industry, as feedstock in chemical processes (e.g., urea or electro-fuels), or geologically sequestered for permanent storage. Today, the primary commercial application of CO<sub>2</sub> is enhanced oil recovery.

The application of CC as a pure-play environmental technology is yet to become economically feasible, but CC technology has been used for decades in other industries including biogas upgrading and the chemical industry. The technology is routinely used as a gas treatment technology in the oil and gas industry, e.g., for purifying natural gas. To lower costs of CO<sub>2</sub> capture compared to the original technologies and thereby further its implementation as an environmental technology, several different CC technologies have been proposed and investigated by the scientific community since the early nineties. Only a few technologies, such as amine-based and oxy-fuel technologies, have been demonstrated in larger scale. The following section will provide a brief overview of the more significant CC technologies and explain the pros and cons in a Danish context.

### i.2.1 Post combustion capture

#### Amine-based CC

The amine-based CC technology is the more mature and more widely demonstrated CC technology available today. It involves scrubbing CO<sub>2</sub> out of the flue gas with an amine solvent and subsequent thermal regeneration of the amine solvent to yield a pure CO<sub>2</sub> stream. The technology is flexible with respect to CO<sub>2</sub> source and capacity, potentially capturing 90% or more of the CO<sub>2</sub> from the source.

Amine scrubbing has been used in smaller scale in the food and beverage industry for several decades to recover CO<sub>2</sub> from a flue gas/process gas stream and turn it into a high purity concentrated CO<sub>2</sub> stream. Amine scrubbing processes are also known within gas treatment (gas sweetening) and various chemical industries to remove CO<sub>2</sub> from process gasses e.g. natural gas, biogas, hydrogen, etc. (The amine scrubbing process for upgrading biogas is described further in the chapter Biogas Upgrading in the *Technology Catalogue for Renewable Fuels*.)

For capture of CO<sub>2</sub> from flue gas streams, the capture plant is installed in the tail-end of the combustion plant with minimal impact and interfaces to the combustion plant/point source. For these reasons the amine CC process is very suitable for retrofitting to existing heat and power plants as well as to other industrial combustion processes. Amine CC technology may also be heat integrated with the steam cycle of boilers and the district heating network to obtain improved overall energy efficiency. Drawbacks with the amine technology is the use of a substantial amount of heat, which may reduce heat output from a Combined Heat and Power (CHP) plant and/or result in a large penalty in electrical efficiency. The capital cost today of the amine process is also significant.

**In recent years, the development of amine technology in a CC context has focused on scale-up and optimization of the process with respect to energy requirements, capital investment and harmful emissions. There are several vendors offering amine-based CC on commercial basis. (The technology is further elaborated in**

401 Amine post combustion carbon capture technology.)

Ongoing research and development work is investigating the classic amine CC process using alternative solvents, such as amino acid salts, ionic liquids, non-aqueous solvents, etc. [1] This may lead to future improvements in energy requirements and investment costs of solvent CC processes, but these alternative solvents are still at low Technology Readiness Level (TRL).

### **Potassium carbonate (PC)**

The potassium carbonate-based CC technology resembles classic amine-based CC. It is installed as an add-on of an existing point source and consists of an absorber and a desorber column with a caustic solvent circulating between them to process the CO<sub>2</sub> gas. The PC technology is also used by chemical industries for removing acid gases from products, e.g., natural gas.

Generally, CO<sub>2</sub> is absorbed at higher pressure (~1-15 bar) and released by a combination of lower pressure (0.5-1.5 bar) and solvent heating in the desorber. CO<sub>2</sub> absorption in potassium carbonate is slower than solvents based on stronger bases like amine solvents. Slower absorption rates translate into larger equipment, and to counteract this, vendors can speed up the reaction by compressing the flue gas and by adding chemical or enzymatic promoters to the solvent.

Available technology variants include: fully electrified processes relying on flue gas compression and internal heat integration; processes relying on part steam, part electrification; and an enzymatically catalysed process using hot water as heat source for releasing CO<sub>2</sub> in the desorber operated below atmospheric pressure. Broadly viewed, the specific energy consumption is similar to amine-based CC, but the different types of input energy (i.e., power/hot water) to drive the process provide possibilities for optimizing the CO<sub>2</sub> capture costs depending on the local availability and costs of these utilities. All technology variants can be integrated with district heating systems to improve overall efficiencies. Further, the technologies share the use of PC solvent, which is environmentally benign and does not introduce new emissions to the treated flue gas.

The TRL of the PC technology for post-combustion application is still lower than its amine counterpart with current efforts being conducted in pilot and demonstration scale. The technology is being studied for full-scale projects and therefore shows promise of advancing to the highest TRL level within this decade.

### **Chilled ammonia/carbonate process**

Chilled ammonia (or ammonium carbonate process) technology is relatively similar to amine CC process except that a solution of ammonium carbonate is used instead of amine. Due to the volatile nature of ammonia the process must be chilled to below ambient temperature to limit ammonia slip. The chilled ammonia process is a proprietary process of Baker Hughes (former part of Alstom).

The advantage of the chilled ammonia process is supposed to be reduced heat consumption, CO<sub>2</sub> recovery at relatively high pressure (5-25 bar) and no emission of amine and degradation products. However, slow absorption kinetics, increased process complexity as well as challenges with handling of solid precipitation of carbonates have proven to be significant disadvantages. In addition, the heat requirement has proven higher than initially anticipated. The process has been demonstrated at relatively large scale (100,000 tpa). The process will be more relevant for more concentrated CO<sub>2</sub> sources.

### **Other solvent systems**

Post combustion processes with alternative solvents, such as non-aqueous solvents, ionic liquids, amino acid salts, phase change solvents, etc., are also under development [1, 2, 3, 4]. The aim with these alternative solvents is to achieve lower energy consumption and reduce the cost of CC technology. Most of the processes involving more novel solvents have not been demonstrated at large scale and are thus at relatively low TRL. Therefore, the energy and cost reductions these alternative solvents may bring relative to amine solvents remain uncertain [5].

### **Solid sorbents**

Post combustion processes with use of solid sorbents instead of liquid solvents are under early-stage development. Both solid adsorption processes working at low temperature suitable for tail-end retrofitting (similar as for amine technology) as well as high temperature processes working at the calcination temperatures of inorganic carbonates (600-900 °C) exist.

For the low temperature process research focuses on developing solid sorbents with good properties for CO<sub>2</sub> capture and high process durability. Examples of sorbents are support materials of carbon, zeolite, metal organic framework (MOF), etc. loaded with amine functional groups [5]. Challenges relate to low cyclic loading of the solid i.e. need to circulate large amounts of solid, relatively rapid deactivation of solid sorbent, and difficulty in developing a robust industrial scale process.

The high temperature sorbent process also referred to as calcium looping applies lime (CaO) or modified lime with other metal oxides to capture CO<sub>2</sub> at high temperature (500-650 °C).[6] The formed solid carbonates are then calcined/regenerated to yield a pure CO<sub>2</sub> stream around 900 °C. Thus, the process requires heat input at high temperature, which may be delivered by direct oxy-firing in the regenerator (hence it may be regarded as oxy-fuel technology) or indirect heating. If used as post combustion technology, calcium looping needs to be significantly integrated with the boiler, which in turn makes it non-suitable for retrofit. Challenges are also related to low lifetime of the sorbent which implies large mass streams of fresh and spent limestone will have to be handled.[5] In the case of a cement kiln where limestone is a major raw material, the short lifetime of the CaO sorbent is not an obstacle as spent CaO sorbent can be used as raw material. Calcium looping can also be applied in gasification plants to remove CO<sub>2</sub> from the gas prior to combustion. This makes the process a pre-combustion capture technology.

Solid sorbent technology is at low TRL and not relevant for near or midterm retrofit projects.

### Membrane technology

Membrane technology is used in the industry today for gas separation. As a CO<sub>2</sub> capture technology, CO<sub>2</sub> selective membranes are under development and have been tested in pilot scale with some success [7]. The main challenge with membrane CC technology is the low partial pressure of CO<sub>2</sub> in flue gas, which make it difficult to obtain adequate driving force (i.e. CO<sub>2</sub> pressure gradient) for transport of CO<sub>2</sub> through the membrane. This is solved by compressing the flue gas and/or maintaining a high vacuum on the permeate side (CO<sub>2</sub> side) of the membrane. Both methods result in substantial electricity consumption [8]. Moreover, as the membrane area required for separation is inversely proportional to the driving force, there will always be trade-off between membrane area and driving force. In addition, membrane technology will be sensitive to dust and pollutants in the flue gas. Membrane CO<sub>2</sub> capture is at low TRL for flue gas and is more ideal for high pressure gas separation.

### Cryogenic separation

Processes for CO<sub>2</sub> capture by freezing out CO<sub>2</sub> from the flue gas i.e. cryogenic separation, are also under development. The low CO<sub>2</sub> partial pressure in flue gas implies that the flue gas will have to be chilled to very low temperature (<-100°C) for the CO<sub>2</sub> to separate (freeze) from the gas. Therefore, the flue gas is compressed to avoid too low temperature. Handling of pollutants in the flue gas and use of expensive compression and chilling machinery are challenges to this technology. The technology may have some potential but is regarded as low TRL with only relatively small-scale pilot plant trials conducted.[9]

#### i.2.2 Oxy-fuel combustion

In oxy-fuel CC, the oxygen required for combustion is separated from air prior to combustion, and the fuel is combusted in oxygen diluted with recycled flue-gas rather than by air. This oxygen-rich, nitrogen-free atmosphere results in a flue-gas consisting mainly of CO<sub>2</sub> and H<sub>2</sub>O (water), thus producing a more concentrated CO<sub>2</sub> stream for easier purification. To keep the temperature down and ensure the flue gas flow in the boiler, 60-70% of the cooled flue gas, which primarily consists of CO<sub>2</sub> and water vapor, is recirculated. After the boiler, water vapor is removed from the flue gas which then typically consists of 70-85 vol% CO<sub>2</sub>. CO<sub>2</sub> can then be further purified and compressed, ready for reuse or disposal. The oxy-fuel technology is further elaborated in section 402 Oxy-fuel combustion technology.

#### i.2.3 Chemical looping combustion

Chemical looping combustion is a novel combustion concept with integrated CC. Oxygen is carried to the combustion process in the form of a solid carrier e.g. metal oxide. The oxygen carrier will be reduced through reaction with the fuel and is hereafter regenerated in a separate oxidizing reactor with air, i.e., x>y in Figure 2. In principle, the technology is a kind of oxy-fuel process as nitrogen is eliminated from the combustion atmosphere. The concept eliminates the need of the air

separation unit of oxy-fuel processes, hence offers a cost saving potential. The working principle of the technology has been demonstrated in pilot plant scale, however, the concept has received little commercial attention and is therefore at low TRL level. The technology is not relevant for retrofit to existing emission sources.

### i.2.4 Pre-combustion capture

Pre-combustion capture covers many different technology concepts. Common for all concepts is that the carbon from the fuel is separated from the combustible gases prior to combustion or use. The concept is only relevant for gasification/reforming plants where fuel is converted to CO<sub>2</sub> and H<sub>2</sub> prior to combustion. The concept is used today for hydrogen plants in the fertilizer industry to remove CO<sub>2</sub> from the feed stream to ammonia plants. Typically, the feed stream is at high pressure hence capture technology with solid sorbents (pressure swing absorption) or less reactive amine (chemical) solvents can be applied. The concept is not relevant for flue gas from existing boilers but may be relevant for new-built energy plants based on gasification. Likewise, it will be relevant for production of emission free hydrogen from natural gas.

### i.2.5 Direct air capture

Direct Air Capture (DAC) technologies harvest CO<sub>2</sub> directly from the air providing a concentrated CO<sub>2</sub> stream. DAC holds the potential to decarbonize the atmosphere, while simultaneously providing a feedstock for functional industrial applications, i.e., e-fuels production. Nevertheless, DAC systems are energy, resource, and cost intensive; the CO<sub>2</sub> concentration in the atmosphere (0.04 volume percent) is low relative to conventional point source capture from flue gases (10–25 volume percent).

DAC technology is still in its infancy and there are many different concepts under development. Most of the technologies and methods for DAC are still being developed in the laboratory and are thus at low TRL. A few technologies have been demonstrated in pilot- and/or commercial plants, but at relatively small scale (up to 11 tons per day).

As DAC in the combination with renewable energy can be used to generate emission free CO<sub>2</sub> for use in CO<sub>2</sub> utilisation processes, e.g. Power to Fuel, or carbon negative solutions in combination with geological CO<sub>2</sub> storage it may be a relevant technology despite the obvious obstacles. Another advantage with the DAC technology is that it will be able to recover CO<sub>2</sub> at any location independently of an emission point source. The two most mature types of DAC technology for near to mid-term deployment are described further in the DAC chapter.

## i.3 CO<sub>2</sub> post treatment

The CO<sub>2</sub> stream, i.e. raw CO<sub>2</sub>, recovered by the different capture technologies typically requires further treatment/conditioning to remove water and trace gas impurities before it can be transported or used by other utilisation technologies.

Most CC technologies (including amine CC and oxy-fuel) will recover a concentrated CO<sub>2</sub> stream at fairly low pressure and saturated with water vapour. For oxy-fuel, the CO<sub>2</sub> purity is lower than post combustion technologies and more extensive treatment is required. This will be further explained in the oxy-fuel technology section.

### i.3.1 CO<sub>2</sub> compression and dehydration

If CO<sub>2</sub> is to be transported in pipeline from capture site to a geological storage or utilisation site, it will have to be compressed and dried to meet suitable conditions for pipeline transport.

Typical CO<sub>2</sub> pipeline pressures will be 80-150 bar to avoid two-phase region and obtain acceptable densities.

The moisture content of the CO<sub>2</sub> will be required to be below 50-400 ppm (depending on specifications) to avoid carbonic acid corrosion and/or hydrate formation. Dehydration processes such as mole sieve adsorption drying or glycol absorption drying is applied for drying of CO<sub>2</sub> gas. Table 4 summaries expected cost and performance of CO<sub>2</sub> compression from 1 to 150 bara.



**Table 4. Energy consumption and cooling for CO<sub>2</sub> compression from 1 to 150 bara and dehydration to <50 ppm moisture. Values estimated based on 8 stage internally geared compressor with inter-cooling to 30°C.**

	Estimated value	comment
<b>Compression electricity</b>	~0.10 MWh/ton CO <sub>2</sub>	0.09-0.12 depending on compressor design. Dehydration is included.
<b>Cooling requirement</b>	~0.16 MWh/ton CO <sub>2</sub>	30-100°C, possible to recover part of the heat
<b>CAPEX CO<sub>2</sub> compression &amp; dehydration</b>	0.2 - 0.5 mill €/t CO <sub>2</sub> /h	Depending on capacity

### i.3.2 CO<sub>2</sub> liquefaction

CO<sub>2</sub> may be liquefied at various temperature and pressure conditions (-56 to 31°C and pressure of 5.2 to 74 bara). Typical conditions for transport, interim storage and trading of industrial CO<sub>2</sub> is in the order of -28°C and 15 bar.

In a standard industrial CO<sub>2</sub> liquefaction solution, concentrated CO<sub>2</sub> is compressed to 15-20 bara and liquefied by chilling at -25 to -30°C. The CO<sub>2</sub> is dehydrated prior to chilling. The requirements for CO<sub>2</sub> dryness for liquid CO<sub>2</sub> will be even more stringent due to greater risk of ice or hydrate formation at the lower temperatures (<30 ppm). Non-condensable gases will also have to be reduced to low levels as these will change the physical properties of the liquid CO<sub>2</sub>. A standard liquefaction plant will include a stripping unit to remove non-condensable gasses, CO<sub>2</sub> dryer and activated carbon (or similar) filter to remove traces of organic compounds from the CC plant. A small loss of CO<sub>2</sub> in the liquefaction process through purging should be expected. This will be further explained in the liquefaction technology section.

Typical energy requirement and CAPEX values of industrial CO<sub>2</sub> liquefaction plants are provided in Table 5.

**Table 5. Energy consumption and cooling requirement for CO<sub>2</sub> liquefaction to -28°C and 15 bar. Values based on today's standard industrial solution for CO<sub>2</sub> liquefaction.**

	Estimated value	comment
<b>Liquefaction electricity</b>	~0.16 MWh/ton CO <sub>2</sub>	Includes chillers, CO <sub>2</sub> dehydration and compression
<b>Cooling requirement</b>	~0.26 MWh/ton CO <sub>2</sub>	~50% of cooling is through chiller air cooler, rest cooling water/cooling tower
<b>CAPEX CO<sub>2</sub> liquefaction</b>	0.4 - 0.8 mill €/t CO <sub>2</sub> /h	Depending on capacity* Qualified through vendor dialogues

Note: (\*) for small capacities, e.g. biogas upgrading plants, CAPEX will be larger [see chapter on liquefaction]

### i.3.3 Intermediate storage, permanent storage, and utilization

Intermediate Storage, Permanent Storage, and Utilization of CO<sub>2</sub> are three distinct approaches in managing CO<sub>2</sub> emissions:

#### 1. Intermediate Storage:

- Objective: Intermediate storage, often referred to as temporary storage, focuses on storing captured CO<sub>2</sub> emissions for a limited period before they are either permanently stored or utilized.
- Duration: The storage period is relatively short-term, usually for days
- Methods: Intermediate storage typically employs tanks to hold the captured CO<sub>2</sub> before it undergoes further processing or disposal.
- Purpose: This approach provides flexibility in managing the timing of CO<sub>2</sub> utilization or permanent storage, allowing for optimization of operations and resource allocation.
- Examples: Intermediate storage is commonly used in carbon capture and utilization (CCU) processes, where CO<sub>2</sub> is temporarily stored before being converted into valuable products like chemicals or fuels.

#### 2. Permanent Storage:

- Objective: Permanent storage aims to securely and indefinitely store CO<sub>2</sub> emissions to prevent their release into the atmosphere, mitigating the impact of climate change.
- Duration: The storage duration is long-term, often spanning decades to centuries or even longer.
- Methods: Geological storage in deep underground formations, such as saline aquifers, depleted oil and gas reservoirs, or unmineable coal seams, is the primary method for permanent storage. Mineralization, which transforms CO<sub>2</sub> into stable carbonates, is another option.
- Purpose: The primary purpose is to reduce greenhouse gas emissions by permanently locking away CO<sub>2</sub> underground or in mineral form.
- Examples: Carbon capture and storage (CCS) projects focus on permanent storage, where captured CO<sub>2</sub> is injected deep underground, preventing its release into the atmosphere.

#### 3. Utilization of CO<sub>2</sub> (CCU):

- Objective: CO<sub>2</sub> utilization involves converting captured CO<sub>2</sub> emissions into valuable products
- Duration: This approach involves the transformation of CO<sub>2</sub> into various products, which can range from chemicals, fuels, fertilizers and building materials
- Methods: Utilization methods include chemical reactions, biological processes (e.g., algae-based systems)
- Purpose: The primary purpose is to transform CO<sub>2</sub> emissions into useful and marketable products, promoting sustainable industries and reducing the carbon footprint.
- Examples: CO<sub>2</sub> utilization can be seen in the production of synthetic fuels, carbon-based materials (e.g., graphene), or mineral carbonation processes that convert CO<sub>2</sub> into stable carbonates.

In summary, intermediate storage serves as a bridge between the initial capture of CO<sub>2</sub> emissions and their subsequent utilization or permanent storage. Permanent storage aims to permanently lock away CO<sub>2</sub> to mitigate climate change, while utilization focuses on turning CO<sub>2</sub> into valuable products to incentivize carbon capture and reduce emissions. Each approach has unique applications and benefits in the context of carbon management and climate change mitigation.

- Description of intermediate storage can be found in the Chapter 412 Intermediate storage of CO<sub>2</sub>.

- Description of permanent storage can be found in the Chapter CO<sub>2</sub> storage
- Description of utilization of CO<sub>2</sub> can be found in Technology Data for Renewable Fuel from the Danish Energy Agency.

- 
- [1] Brandl, Patrick, et al. "A century of re-exploring CO<sub>2</sub> capture solvents." *International Journal of Greenhouse Gas Control* 120 (2022): 103771.
- [2] Arne Gladis, et al. "Pilot scale absorption experiments with carbonic anhydrase-enhanced MDEA- Benchmarking with 30 wt% MEA," *International Journal of Greenhouse Gas Control* 82 (2019) 69–85
- [3] Hendy Thee, et al., "Carbonic anhydrase promoted absorption of CO<sub>2</sub> into potassium carbonate solutions" <https://doi.org/10.1002/ghg.1455>
- [4] M. Lail, J. Tanthana, L. Coleman. Non-aqueous solvent (NAS) CO<sub>2</sub> capture process. *Energy Procedia* 63 (2014) 580-594.
- [5] J. Wang, L. Huang, R. Yang, Z. Zhang, J. Wu, Y. Gao, Q. Wang, D. O'Hare and Z. Zhong. Recent Advances in Solid Sorbents for CO<sub>2</sub> Capture and New Development Trends. *Energy Environ. Sci.*, 2014, 7, 3478.
- [6] CO<sub>2</sub> Capture from Flue gas using Amino acid salt solutions. PhD thesis by Benedicte Mai Lerche, 2012. CERE, DTU.
- [7] M-B Hägga, A. Lindbråthen, X. Hea, S.G. Nodeland, T. Cantero. Pilot demonstration reporting on CO<sub>2</sub> capture from a cement plant using hollow fiber process. *Energy Procedia* 114 (2017), 6150 – 6165.
- [8] Y. Wang, L. Zhao, A. Otto, M. Robinius, D. Stolten. A Review of Post-combustion CO<sub>2</sub> Capture Technologies from Coal-fired Power Plants. *Energy Procedia* 114 (2017), 650 – 665.
- [9] L. Baxter. Cryogenic Carbon Capture Development. Presentation by Sustainable Energy Solutions August 24, 2017. Project NETL FE-0028697.

### 401 Amine post combustion carbon capture technology

#### Contact information

- Contact information: Danish Energy Agency: Emil Esketveit Rasmussen emrm@ens.dk; Christoph Wolter chwo@ens.dk
- Author: Mads Borgbjerg Jensen from COWI

#### Typical scope in first Scandinavian CCS projects

The first post-combustion CCS projects in Scandinavia are purposed for permanent storage, as dictated by their respective public funding schemes. [10, 11] The Norwegian Longship CCS project supported by the Norwegian state, and the Danish CCS project Ørsted Kalundborg Hub supported by the Danish state have both signed contracts with the Norwegian off-shore storage facility, Northern Lights. Despite large technical potentials for less expensive onshore storage in e.g. Denmark, the first CCS projects will have to design their projects for ship transport to offshore storage facilities, which will be ready for commercial operation first.

The main scope of the first retrofitted CC plants in Denmark will consequently include:

- CC plant
- CO<sub>2</sub> compression and liquefaction
- Interim CO<sub>2</sub> storage and export facilities

If onshore storage becomes a commercial option in Denmark, CO<sub>2</sub> pipelines may be installed to connect CO<sub>2</sub> point sources with these storage sites. In this case, future projects should not require CO<sub>2</sub> liquefaction and interim storage facilities but will have to clean and compress the CO<sub>2</sub> to pipeline transport conditions instead. CO<sub>2</sub> pipeline transport is exploited widely in the USA, where captured CO<sub>2</sub> may be compressed up to 150 bar and finds commercial use in enhanced oil recovery (EOR) operations.

Another key scope of any retrofit CCS project is heat integration with the existing facility. It must be considered if the process steam needed for CO<sub>2</sub> desorption in an amine plant can be extracted from existing steam generation or requires a new-build installation. Further, the potential for integrating waste heat recovery with the district heating network will be important for driving down the cost of the energy-intensive amine CC processes and CO<sub>2</sub> compression/liquefaction units, which require immense cooling duty. The district heating network offers a possibility for valorizing this process heat, which is otherwise wasted.

#### Brief technology description

The amine CC technology is based on cyclic absorption and desorption (stripping) processes. The CO<sub>2</sub> (which is an acidic gas) is absorbed from the flue gas by a circulating aqueous amine solution (alkaline solution) and released as a concentrated CO<sub>2</sub> stream through thermal regeneration of the amine solution, i.e. applying heat to the solution, in a desorber. The CO<sub>2</sub> capture process is thus driven by thermal energy. The CO<sub>2</sub> is cleaned, dried, and liquified (or only compressed) downstream of the amine absorption loop in adherence with its end-use application. The working principle of the process and its basic units are illustrated in Figure 8.

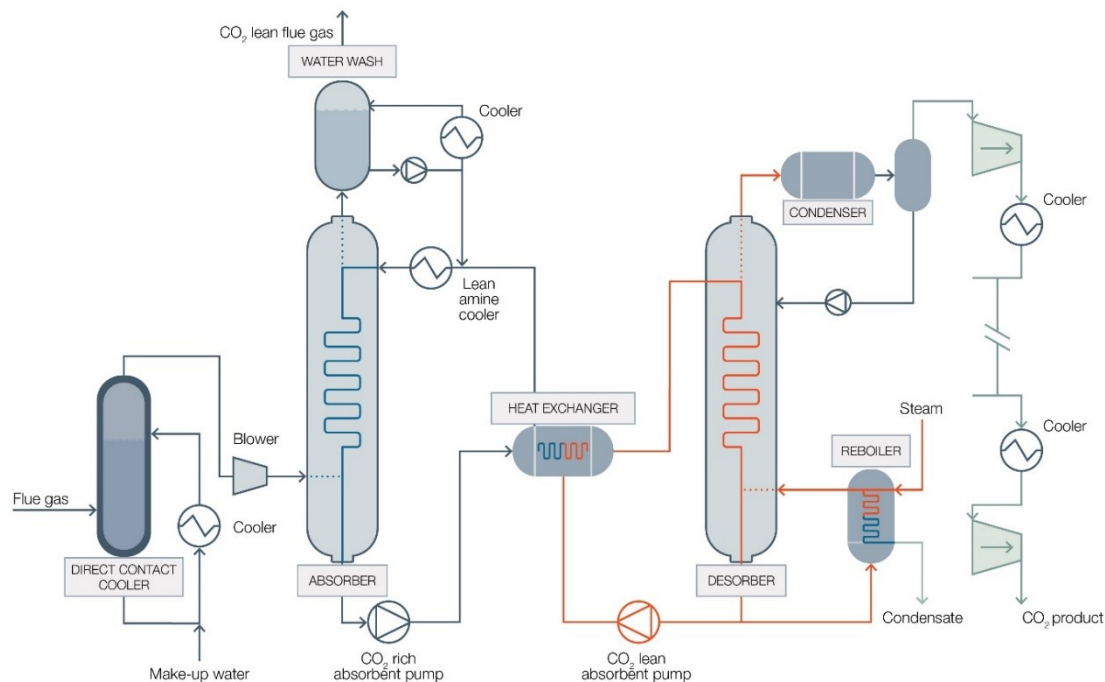

**Figure 8. Schematic illustration of amine-based CO<sub>2</sub> capture process. Flue gas is cooled in a pre-treatment unit prior to entering the CO<sub>2</sub> capture unit where CO<sub>2</sub> is washed out of the stream by an amine solution. The CO<sub>2</sub> gas is stripped from the amine solution, whereby it is regenerated by applying heat in a stripper (desorber). The recovered CO<sub>2</sub> may be compressed and dehydrated for pipeline transportation or liquefied for export by ship or truck.**

A typical amine based CC plant will be composed of the following main units:

### Flue gas pre-treatment

Amine based CO<sub>2</sub> processes require that the flue gas is relatively cool and clean, *i.e.*, contains low concentrations of dust and acidic pollutants before contact with the amine solution. A flue gas stream which is too warm will adversely affect the CO<sub>2</sub> absorption equilibrium resulting in an increased energy demand of the capture process. The presence of flue gas pollutants such as SO<sub>2</sub>, HCl and NO<sub>2</sub> will inactivate the amine by irreversible absorption or degradation. This may in turn lead to excessive amine consumption, emission of amine degradation products, corrosion in the amine process as well as creation of more chemical waste. NO<sub>2</sub> is a particular concern as its reaction with amine or amine degradation products create carcinogenic nitrosamines. Furthermore, the presence of significant mass loadings of submicron particles in the flue gas, *e.g.*, acid mist, may lead to formation of amine aerosol emission. Proper upstream flue gas cleaning is, therefore, absolutely vital to safe and efficient performance of amine-based post combustion CC processes.

Typically, the flue gas is preconditioned in a pre-scrubber or direct contact cooler. The pre-scrubber will quench the flue gas to typically 30-40°C and scrub out most remaining acidic pollutants and fly ash. Caustic solution is applied to remove the acid pollutants and keep the scrubbing water close to neutral pH. Since the flue gas is cooled below its dewpoint, a bleed stream of condensate containing the absorbed pollutants is produced. Depending on the purity of the flue gas, the condensate requires some degree of treatment before discharge to public sewer. The cooling of the flue gas below its dew point also requires significant heat removal. This heat may also be upgraded with heat pump technology to be useful for district heating.

In the case of a thermal power plant or other industrial emission source that is already equipped with flue gas condensation, the addition of the described preconditioning flue gas condenser unit can be considered redundant, as the existing system serves the same function: cooling and removal of acidic pollutants.

### Amine absorption loop

Following pre-treatment, the flue gas is directed to a packed bed absorption column, where the CO<sub>2</sub> is scrubbed out of the flue gas through contact with the amine solution (solvent). The absorber will be the largest structure of the CC plant. At the top of the absorber tower emission control sections (water wash and demisters) are fitted to minimize emission of amine and degradation products along with the treated flue gas. Significant heat will be released in the absorber due to the heat of absorption of CO<sub>2</sub>, increasing flue gas temperatures by 25-35 °C. Cooling is therefore applied to maintain an efficient absorption equilibrium and limit the evaporative loss of amine with the treated flue gas.

The CO<sub>2</sub> loaded amine solution (rich amine) is pumped to a regeneration tower (desorber) after pre-heating with hot regenerated amine solution in the rich-lean cross heat exchanger. A reboiler – the heat exchanger device that heats the solvent - driven by low pressure steam (typically 3-5 bara, 130-150°C) is installed in the bottom of the regeneration tower to supply the heat for releasing the CO<sub>2</sub> and regenerating the amine solution. The necessary heat supply in the reboiler is comprised of (1) the heat needed to raise the temperature of the concentrated solvent to the reboiler temperature; (2) heat of vaporization required for generating stripping steam in the reboiler; (3) the equivalent amount of heat as heat of absorption; (4) heat losses in the hot part of the system. The hot CO<sub>2</sub> and water vapours the top of the desorber will be cooled in a condenser and the aqueous condensate will be refluxed. The concentrated CO<sub>2</sub> gas stream leaving the condenser is the product from the CC process. Typical operating conditions of the desorber are around 120 °C and 2 bara in the bottom/reboiler, and 100 °C and 2 bara in the top. The condenser will cool the CO<sub>2</sub> to 30-40 °C. The conditions will vary somewhat with the specific technology and there is also some flexibility in the design to adjust parameters.

All energy (steam, pump works) supplied to the CC plant must be cooled away to maintain balance in the process. Process cooling is further detailed in *Output* below.

### Amine reclamation unit

Amine degradation products and traces of flue gas pollutants will build-up in the amine solution over time. To maintain the performance of the solvent and avoid excessive emissions up through the stack, a reclamation process is applied where the active amine is recovered, and degradation products and pollutants are rejected as chemical waste. The reclamation process can be a thermal process that requires heat from steam (6-10 bara) and caustic solutions. Alternatively, ion-exchange processes can be used, but consume more chemicals and water. [12] Some processes will also have continuous activated carbon filtration of the amine solution to continuously remove some degradation products.

## Input

The energy consumption for amine CC processes is significant and typically the largest element in the OPEX for the technology. The main energy consumption for the process is in the form of thermal energy, typically low-pressure (LP) steam (3-5 bara, 130-150 °C) for regeneration of the solvent in the reboiler/desorber system. Depending on the specific technology (vendor), the CO<sub>2</sub> concentration in the flue gas and the flue gas temperature, the thermal energy demand is typically reported to be within the interval listed in Table 6. For flue gases with a CO<sub>2</sub> concentration above 6-8 % the specific energy requirement will only decrease marginally with increasing CO<sub>2</sub> concentration. At lower concentrations, *e.g.*, gas turbine exhaust (3-4% CO<sub>2</sub>) there could be an energy penalty of about 10-15%. Different options exist for reducing the thermal energy consumption of the CC process such as mechanical vapour compression, inter-cooling in absorber, internal heat integration, *etc.* [13]. Whether these options are included in the CC process design is determined by the technology vendor.

The electricity demand for the amine based CC process is relatively modest as shown in Table 6. Electricity is mainly required for various recirculation pumps and the flue gas fan (increased pressure drop). Electricity for cooling water circulation is included. If a CO<sub>2</sub> post treatment process is included, where CO<sub>2</sub> is compressed to pipeline transport pressure or liquefied, the electricity consumption will be substantially higher as further described in section i.3.

Amine make-up needs to be added to the process to compensate for degradation and losses. The quantity is highly amine specific hence, it depends on the specific vendor technology. Typically, the variation range is as listed in Table 6. The classic amine process based on monoethanolamine (MEA) will see an amine consumption in the higher end whereas processes with more advanced amine solvents such as MHI's KS-1 or Aker Solutions S26 [14] solvents will be in the lower end.

Typical range for caustic soda consumption for flue gas pre-cooling and reclaiming is shown in Table 6. Other consumables such as activated carbon, lube oil, etc. are required in minor quantities. Caustic soda and the other minor consumables will typically constitute less than 1% of OPEX and can be ignored for initial evaluations.

**Table 6. Typical main inputs for amine based CC processes, including flue gas pretreatment and booster fan but excluding CO<sub>2</sub> compression and liquefaction. \*Estimated from pumping and fan works. \*\* Estimated based on 0-20 ppm SO<sub>2</sub> in flue gas + 0.1-0.3 kg/ton CO<sub>2</sub> for reclaiming use.**

Parameter	Typical variation	Ref.	Comment
<b>Reboiler LP steam demand</b>	2.5-3.5 GJ/t CO <sub>2</sub> or 0.7 – 1.0 MWh/t CO <sub>2</sub> output (3-5 bara and 130-150°C)	[14, 15, 16, 17]	Depending on vendor technology
<b>Electricity demand</b>	20-40 kWh/t CO <sub>2</sub> output	*	Depending on vendor technology. Higher power demands likely for process design with complex heat integration, e.g. mechanical vapor recompression (MVR). High electricity consumption is usually linked to lower steam consumption.
<b>Amine consumption</b>	0.2 – 1.6 kg/t CO <sub>2</sub> output	[14]	Depending on vendor technology
<b>Caustic soda consumption</b>	0.1-0.5 kg/t CO <sub>2</sub> output	**	Depending on flue gas quality e.g. SO <sub>2</sub> , HCl, and specific amine

## Output

Main output of the process is the concentrated CO<sub>2</sub> stream, *i.e.* the captured CO<sub>2</sub>. The process is typically designed for capturing 90% of the CO<sub>2</sub> content in the flue gas, while the remaining CO<sub>2</sub> is led to the stack through the flue gas stream. The capture rate can be designed for even higher capture rates at the expense of increased steam demand for regeneration and/or at increased CC plant investment cost.

The CO<sub>2</sub> recovered from amine CC plants is highly pure. On dry basis, the CO<sub>2</sub> purity will typically be 99.95 %-vol or higher. The CO<sub>2</sub> will normally be saturated with water vapour at the conditions it leaves the process (30-40 °C, 1-3 bara), however, which corresponds to 2-3 %-vol. Main pollutants will be O<sub>2</sub> and N<sub>2</sub> as well as traces of amine and volatile degradation products from the amine solvent (*e.g.* ammonia, aldehydes), and traces of flue gas pollutants such as NO<sub>x</sub> and SO<sub>x</sub>.

Even though the CO<sub>2</sub> has a high purity out of the CC process, it is still necessary to remove water and reduce the level of trace impurities to meet the CO<sub>2</sub> product specification, whether for permanent storage, utilization, or food and beverage industry.[18] The technical systems in the post treatment unit depend upon the specific utilization and if and how CO<sub>2</sub> is transported from the capture site. If CO<sub>2</sub> is exported as liquid, as seen for the first CCS projects in Norway and Sweden, the CO<sub>2</sub> is compressed, dried for water removal, and condensed at low temperature while removing non-condensable gases. If the CO<sub>2</sub> is exported by pipeline, the conditioning is mainly limited to compression and water removal to meet the conditions for pipeline transport. Water removal is an important part of CO<sub>2</sub> conditioning processes to avoid issues related to corrosion and/or ice formation in process equipment and transport systems.

CO<sub>2</sub> post treatment is further described in section i.3.



Another main output from the amine CC unit is low grade heat as listed in Table 7. Approximately the same amount of heat that is supplied to the CC process in the reboiler needs to be removed by cooling or used for district heating. The process heat will be available at two or more distinct temperatures; typically around 80 °C in the desorber, and around 50 °C in the absorber. If flue gas pre-cooling is required, significant additional cooling may be needed, depending on whether flue gas condensation is already part of the existing plant and to which level the flue gas is already cooled. The amount of cooling duty for flue gas pre-cooling can be estimated from flue gas inlet conditions. As an example, if flue gas at 90 °C with 20%-vol moisture and 13%-vol CO<sub>2</sub> is cooled to 35 °C, approx. 0.5 MWh/t CO<sub>2</sub> output additional cooling is required and 0.5 m<sup>3</sup>/t CO<sub>2</sub> output flue gas condensate needs to be discharged or treated for onsite usage as, *e.g.*, deionate.

Minor outputs from the process are for example chemical waste from the reclaiming or spent activated carbon.

**Table 7. Typical main outputs from amine based CC processes. \* Estimated values based on typical inlet conditions for CHP flue gas.**

Parameter	Typical variation	Ref.	Comment
CO <sub>2</sub> capture	85-95% (of flue gas CO <sub>2</sub> content)	[14, 15, 19]	Most studies are based on 90%
Heat output excl. flue gas pre-cooling	0.7–1.0 MWh/t CO <sub>2</sub> output 30% available at ~80 °C. 70% available at ~50 °C	*	Cooling duty analogous to reboiler heat input
Heat output (cooling) flue gas pre-cooling	0-0.5 MWh/t CO <sub>2</sub> output Heat available at ~40 °C	*	Depending on flue gas composition and temperature from existing plant
Flue gas condensate from pre-cooling	0-0.6 m <sup>3</sup> H <sub>2</sub> O/t CO <sub>2</sub> output	*	Depending on flue gas composition and temperature from existing plant

### Energy balance

An energy balance for a CO<sub>2</sub> capture facility with a flue gas stream from a 100 MW<sub>th</sub> biomass-fired energy plant including CO<sub>2</sub> compression and dehydration is illustrated in Figure 9 and, in Figure 10, the case of transport in pipeline and intermediate storage are depicted, respectively. The biomass fired energy plant is assumed to be equipped with flue gas condensation (as in the data sheet), hence no additional pre-cooling of flue gas is included. Typical CO<sub>2</sub> concentration ranges for different plant types can be found in Table 8. Electricity to pump cooling water/heat output stream from CC and compression plant is also included in the energy balance.

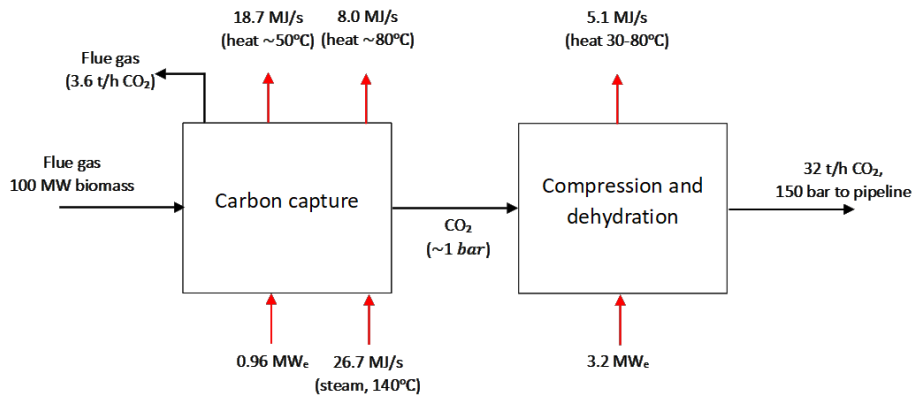

Figure 9. Illustration of energy balance for a CO<sub>2</sub> capture and compression plant treating all flue gas from a 100 MW<sub>th</sub> biomass boiler that is equipped with flue gas condensation. 90% of the CO<sub>2</sub> in the flue gas is captured corresponding to 32 t CO<sub>2</sub> output per hour. Black arrows: Mass streams. Red arrows: Energy streams.

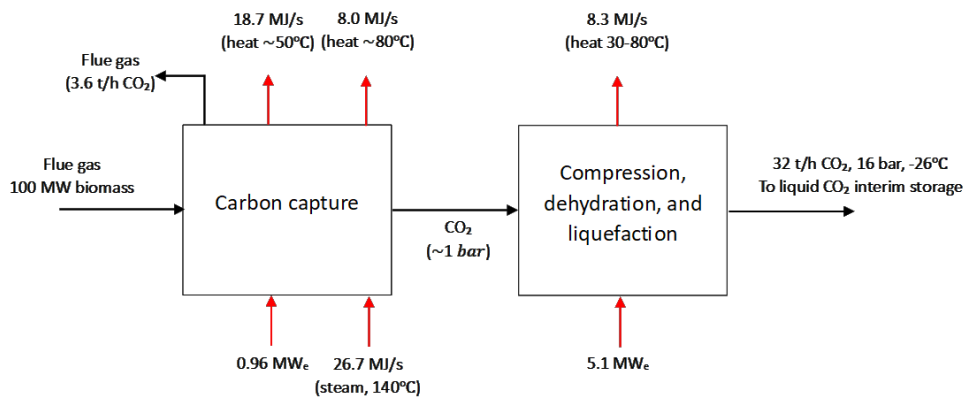

Figure 10. Illustration of energy balance for a CO<sub>2</sub> capture and liquefaction plant treating all flue gas from a 100 MW<sub>th</sub> biomass boiler that is equipped with flue gas condensation. 90% of the CO<sub>2</sub> in the flue gas is captured corresponding to 32 t CO<sub>2</sub> output per hour. Black arrows: Mass streams. Red arrows: Energy streams.

## Application potential

The amine-based CC process is expected to be suitable for retrofit to existing heat and power plants as well as to other industrial combustion processes. Amine-based technologies have been selected for the first post combustion CC plants in Denmark and Norway [10, 11], and are also deployed at the World’s first commercial post combustion plants at Petra Nova and SaskPower Boundary Dam (described in further detail in Examples of planned and operating large-scale plants).

Installing a large process unit to an existing site in operation is always complicated. Typically, there may be challenges with space availability, tie-ins to existing plants, adequacy of existing utilities, etc., which are all factors affecting the contingency.

For retrofitting an amine CC to power generation boilers, the LP steam for the amine plant can in many cases be extracted from the steam turbine of the power plant on account of a significant increased parasitic load on the order of 20-40% of a power plant net electricity output.[20] The benefit of extracting steam from an existing production is that an investment in additional utility boiler for supply of steam to the CC plant is avoided. The possibility for recovering the process heat into a district heating network as in Denmark improves the business case of post CC processes due to improved energy efficiency.

### Combined heat and power plants

A retrofit case of amine CC to an existing CHP plant is illustrated in Figure 11. The CC plant will typically have tie-in to the CHP plant in the tail-end just before the flue gas stack. Amine CC may therefore be applied to nearly all kinds of combustion technologies and fuels such as biomass CHP, Waste to Energy or fossil fuel fired plants. A CO<sub>2</sub> flue booster fan is typically included in the scope of the amine plant to overcome the increased pressure drop. The treated CO<sub>2</sub> lean flue gas (wet conditions) may be vented directly from the top of the absorber in a dedicated stack or alternatively routed back to the power plant's stack (more costly). Depending on local legislation, reheat of flue gas may be required.

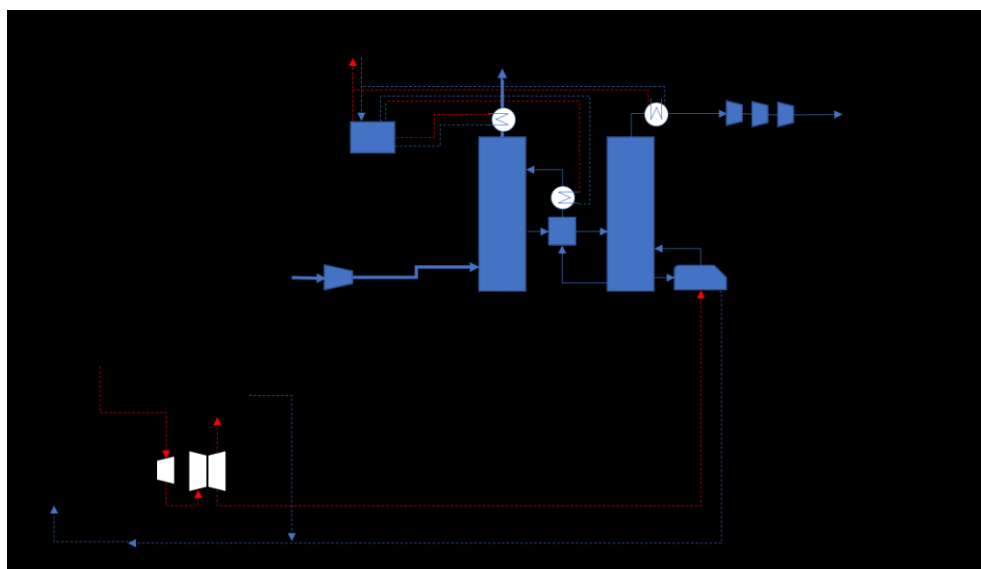

**Figure 11. Illustration of amine CC retrofit to CHP plant. The CC plant includes a booster fan and CO<sub>2</sub> compression plant. The pre-scrubber has been omitted as the CHP has flue gas condensation and excellent flue gas cleaning. As an option heat pumps may be used to upgrade low value heat from CC plant to district heating.**

In the CHP case it will typically be attractive to extract steam at low pressure from the turbine to drive the reboiler in the CC process as shown in Figure 11. This of course depends on the specific steam turbine design, as some turbines will not allow for steam extraction, in which case a major turbine modification may be required or even turbine replacement. To compensate for the reduced LP steam availability for district heating (DH), waste heat from the amine process and/or CO<sub>2</sub> compression/liquefaction may be integrated with the district heating network. About 70% of the waste heat will be available at relatively low temperature (about 50°C in average) which requires upgrade with heat pumps if to be used in the DH network. Heat pumps for upgrade of low temperature heat is not included in the energy numbers and CAPEX estimate in the data sheet (can be estimated from Technology Catalogue chapter regarding Technology Data for DH heat pumps), 30% of waste heat is available around 80 °C, hence may be exchanged directly against DH water.

Depending on the possibility for heat integration with DH network and the available cooling capacity at the CHP, new cooling water capacity may need to be erected as part of the CC project.

As mentioned in the section Brief technology description, the pre-scrubber may be omitted from retrofit scope if the CHP is equipped with flue gas condensation.

### Other industrial emission sources

Amine CC will also be relevant for decarbonising emissions from other industries such as refinery emission sources, cement kilns, reforming plants, steel industry, large industrial utility boilers and more. In a Danish context, the largest industrial emission sources besides energy plants are cement kilns and refineries.

For cement kiln the tie-in will again be close to the existing stack downstream flue gas cleaning equipment. The CO<sub>2</sub> content of cement flue gas is typically higher (20-30%-vol) than for power plants (10-15%-vol), implying that the absorber part will be more compact. At cement kilns steam is not normally available, hence a steam boiler or other heating plant will have to be included in the scope for an amine CC retrofit, which will increase costs and emissions to be captured. Some cement kilns may have waste heat available after the preheating tower or in the clinker cooler excess air vent. Part of the heat demand of the amine CC process may therefore be covered by installation of Waste Heat Recovery Units (WHRUs) in the cement processing lines. Some cement kilns have already exploited this heat in a steam cycle for cogeneration of power. In this case it will presumably be cost-efficient to use the produced steam for the CC plant instead of power generation.

The required cooling water capacity for a CC plant is unlikely to be present at the cement plant, hence this must typically be established as part of the CC project.

Refinery emission sources typically consist of several smaller point sources from fired heaters, crackers, auxiliary boilers, etc. The point sources may be combined and fed to a common capture plant for cost saving. At refineries several heat integration options would typically be available. It is however likely that an additional steam boiler will be required if a high share of the CO<sub>2</sub> emission should be captured.

### Typical capacities

The data sheet for "Post combustion - small biomass" is based on a 32-34 t CO<sub>2</sub> output/h capacity (100 MWth), whereas "Post combustion - large biomass" (500 MWth) and "Post combustion - cement kiln" are based on 150-170 t CO<sub>2</sub> output/h.

Existing post-combustion amine-based CC plants have been designed with capacities ranging 10-200 t CO<sub>2</sub> output/h (see *Examples of planned and operating large-scale plants*).

### Space requirement

The specific space requirement ( $m^2/[t \text{ CO}_2 \text{ output/h}]$ ) for an amine CC plant depends on scale, scope, and whether the plant consists of one unit or more parallel units with reduced capacity. For locations with constraints on area it will be possible to locate equipment on different floors in a building. The following space requirements shall consequently only be used for initial estimates.

For amine CC plants with capacities in the range 30-40 t CO<sub>2</sub> output/h, the occupied area will be on the order of 40-50 m<sup>2</sup>/[t CO<sub>2</sub> output/h].

For amine CC plants with capacities in the range 150-200 t CO<sub>2</sub> output/h, the occupied area will be on the order of 30-40 m<sup>2</sup>/[t CO<sub>2</sub> output/h].

For CO<sub>2</sub> compression and dehydration approximately 12 m<sup>2</sup>/[t CO<sub>2</sub> output/h] additional is required. If liquefied CO<sub>2</sub> is produced, there is an additional need for 6 m<sup>2</sup>/[t CO<sub>2</sub> output/h], and additional space should be allocated for CO<sub>2</sub> storage tanks and CO<sub>2</sub> export facilities.

Additional area will be required for cooling towers or air coolers if no cooling water is available, and heat pumps if low-temperature process heat shall be recovered into the district heating system.

### Modularization

Several CC vendors are already working on 'standardized' modular units to improve their competitiveness by being able to reduce CAPEX costs for future projects. Compared to tailor-made systems, standard units can be mass produced based on existing engineering specifications, be prepared for efficient onsite assembly, and be designed for standard transport options e.g., truck.

There are potential issues related to selection of standard solutions. First and foremost, these will be designed for specific CO<sub>2</sub> capture capacities that may not fit perfectly with the amount of generated CO<sub>2</sub> at the emission site in question, especially when the operational profile can be very season-dependent, e.g., high load during winter and low load during summer due to heat demand. Secondly, the standard solutions are likely equipped with a flue gas condenser unit, which – as previously described - may be redundant equipment if such unit is already installed at the existing facility. Other considerations from the perspective of CHP plants are to what extent these modular solutions will enable process heat recovery into the district heating system, and how they compare with tailor-made solutions in terms of steam consumption.

As nearly all CC plant vendors are yet to deliver their first full-scale CC plant it is too early to identify the potential cost impact of future standard solutions on overall project economy.

### Part-load performance

Amine-based CC plants can be designed to withstand a large operational span with typical turndown capabilities being 20-30% of the flue gas flow at the design point. The capture-% can be maintained consistently in this operating range. To ensure that the existing plant can operate independently of the CC plant, it is necessary to include the possibility for flue gas bypass of the post-combustion CC plant.

Part load operation of an amine-based CC unit is secured by adjusting the solvent flow rate and the steam supply proportionally to the incoming flue gas flow. The specific steam consumption remains constant with decreasing flue gas flowrate until around 50% turndown, below which the specific steam consumption increases. The effect of turndown on the specific steam consumption depends on the specific amines being deployed, including their blends and concentrations, as well as the turndown ratio to be used.

The 50% turndown is a typical minimum solvent circulation rate to achieve adequate conditions for CO<sub>2</sub> absorption and desorption in the absorber and desorber columns. When the flue gas turndown decreases below the minimum solvent circulation rate, the disproportional gas-liquid flow ratio leads to increased specific steam consumption for the reboiler, and power consumption for solvent circulation pumps. The specific steam consumption increases due to changes in solvent loading<sup>i</sup>. Based on an assessment of the relationship between lean solvent loading and specific reboiler duty from published data, 5-10% extra steam consumption can be expected at 20-30% flue gas load – stressing that this will ultimately be case - and vendor dependent. For the classical MEA solvent, the consequence of a higher lean solvent loading on steam consumption is lower than, e.g., piperazine and DEA/AMP blends [21,22]

In practice, turndown limitations for amine-based CO<sub>2</sub> capture plants will be components in the CO<sub>2</sub> post treatment facility, typically the CO<sub>2</sub> compressors. Depending on the compressor type, the power consumption scales proportionally until around 70% load. At lower loads the operating costs increase because of a requirement for expansion and recirculation of already compressed CO<sub>2</sub> to reach a minimum gas flow at the compressor intake. It is possible to mitigate this OPEX increase by installing parallel CO<sub>2</sub> compressor trains with part load capacity, however at increased CAPEX.

### Regulation ability

The CC unit can regulate up and down relatively quickly by adjusting the solvent circulation rate and steam flow to the reboiler. The CC process can follow load changes on similar timescale as seen in energy production plants. At the Technology Centre Mongstad test facility, ramp rates up to 10%/min have been demonstrated for the amine process, however, the time required to reach a stable process at the new set point depends on the step change size [23, 24]. Stabilization time for

---

<sup>i</sup> Solvent loading is defined as the CO<sub>2</sub> content of the solvent relative to its amine concentration (measured in mol CO<sub>2</sub> / mol amine).

smaller step changes (5%) may be achieved on a minute timescale, while process stabilization for larger step changes (20%) will be on an hourly timescale.

Starting the process up from cold conditions may involve slowly heating the system over 2-4 hours depending on the size of solvent inventory. If the CC plant is kept in hot standby conditions, i.e., maintained at operating temperature, the CC plant will be able to start-up to full load in less than 30 mins.

## CO<sub>2</sub> concentration in flue gas

The CO<sub>2</sub> concentration in flue gas varies for different industrial processes (Table 8). For CHP plants, the CO<sub>2</sub> concentration depends on the fuel composition and use of excess air in the combustion process. For other industries, the CO<sub>2</sub> concentration is influenced by the presence of CO<sub>2</sub>-releasing processes other than combustion, e.g., the calcination in cement production.

**Table 8 Typical CO<sub>2</sub> concentration ranges for different plant types.**

Flue gas source	CO <sub>2</sub> concentration range vol-% (at dry conditions and actual O <sub>2</sub> concentration <sup>†</sup> )
Gas turbine	2-4
Waste-fired power plant	9-14
Biomass-fired power plant	13-17
Cement plant	20-30

<sup>†</sup>The CO<sub>2</sub> concentration is stated at dry conditions, as existing plants will have different H<sub>2</sub>O-concentrations in their flue gas depending on fuel and flue gas condensing systems. The flue gas will have a similar water content before entering the CO<sub>2</sub> absorption process due to the process requirements for upstream flue gas cooling. The CO<sub>2</sub> concentration is stated at actual O<sub>2</sub> concentrations to reflect variability at actual conditions.

The CO<sub>2</sub> concentration in flue gas has high influence on CC costs: CC costs decreases with increasing CO<sub>2</sub> concentration as smaller amounts of diluting gases need processing per amount of captured CO<sub>2</sub>. The cost reduction is predominantly CAPEX-driven. To illustrate the influence of flue gas CO<sub>2</sub> concentration on CC plant CAPEX and utility consumption, a CC plant has been simulated with constant flue gas flow but varying CO<sub>2</sub> concentrations using a commercial process simulation tool (Figure 12). The simulated CC processes use 30 wt% MEA solvent with 90% capture rate and estimate approximately 40% savings in installed equipment costs when comparing 12% CO<sub>2</sub> flue gas concentration with 4% CO<sub>2</sub>. The modelled system only contains the core CC unit, i.e., absorber, desorber, and necessary heat exchangers. Based on a more complete economic assessment of the whole value chain (capture, transport, and storage), the Global CCS Institute estimates ~20% lowered costs per ton CO<sub>2</sub> for 12% CO<sub>2</sub> flue gas concentration compared to 4% CO<sub>2</sub> [25].

Regarding OPEX, the specific power consumption for the flue gas blower is inversely proportional with the CO<sub>2</sub> concentration and therefore decreases with increasing CO<sub>2</sub> content. The influence of CO<sub>2</sub> concentration on the specific steam consumption is solvent specific. It generally decreases with increasing CO<sub>2</sub> concentration due to the positive relationship between CO<sub>2</sub> concentration and the solvent's CO<sub>2</sub> absorption capacity [26]. For the well-described 30 wt% MEA solvent, the steam consumption reduces only minorly above ~10% CO<sub>2</sub> concentration in the flue gas (Figure 12 B). Other amines may experience a larger effect, depending on its thermodynamic properties.

The diminishing effect of increasing CO<sub>2</sub> concentration on steam consumption at high concentrations for MEA is partly explained by a concomitant increase in solvent temperature due to more reaction heat. It will be possible to mitigate the consequent effect of higher solvent temperature and thereby reduce steam consumption even further, by intercooling the solvent in the absorber [27]. The absorber intercooling concept is used in some commercial processes for this reason [28].

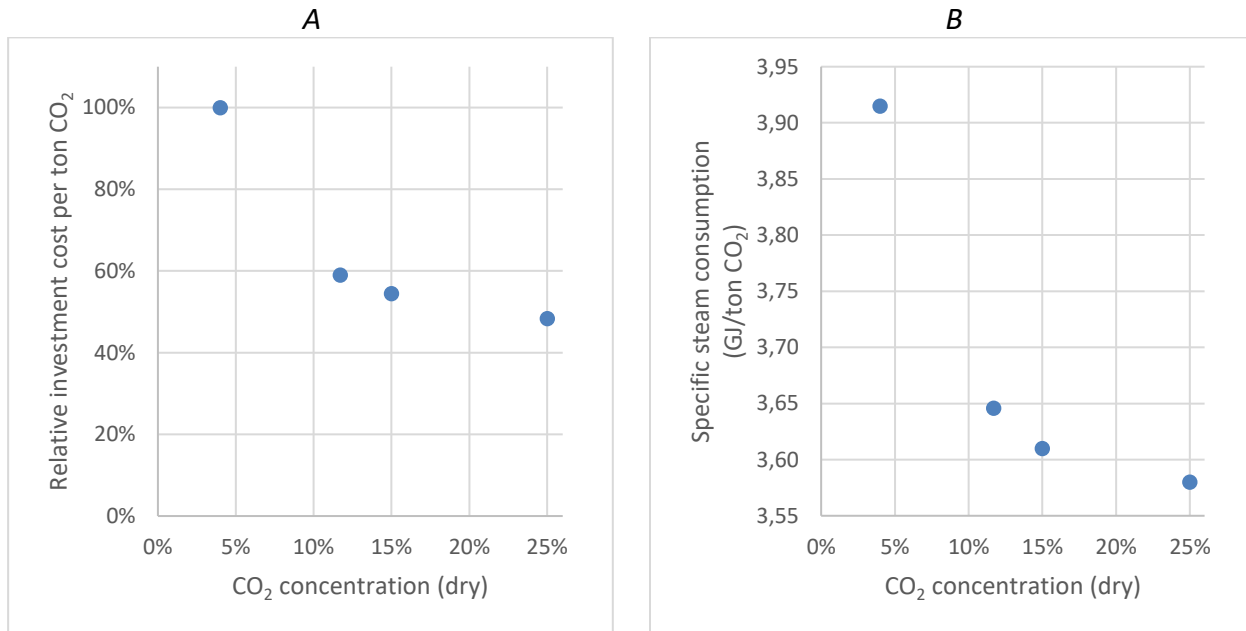

**Figure 12. A. Comparison of relative investment costs (USD / (ton/h)) in equipment for CC for different CO<sub>2</sub> concentrations in flue gas. B. Comparison of the specific steam consumption for different CO<sub>2</sub> concentrations in flue gas. Data origins from CC models of 30 wt% MEA solvent in Aspen HYSYS V14, using 90% capture rate at constant flue gas flow rates but varying CO<sub>2</sub> content. The model contains main equipment for CC only, i.e., absorber, desorber and heat exchangers. Flue gas pre-treatment, CO<sub>2</sub> conditioning, and utility systems are not included. Intercooling was not included in the absorber. The absorber and desorber were dimensioned for 80% flooding limit in all cases. Aspen Process Economic Analyzer was used to estimate equipment costs.**

## Advantages/disadvantages

CC deployment for post-combustion CC is still limited. The shortage of project references mean that the listed advantages/disadvantages are partly based on expectations to the systems. Significant learnings should be expected in the coming Scandinavian CC projects in terms of heat integration, flexibility, and plant reliability. The *expected* main advantages and disadvantages by amine-based CC can be summarised as follows:

### Advantages:

- Can facilitate deep CO<sub>2</sub> emission reductions (+90%) from an emission point source. However, this is yet to be demonstrated on a continuous basis at scale, since existing commercial reference plants have experienced operational issues and underperformance (see *Examples of planned and operating large-scale plants*).



- Technology is offered commercially by multiple vendors in a large capacity range. Several vendors have operational experience from demonstration or full-scale plants (see *Examples of planned and operating large-scale plants*).
- Flexible with respect to flue gas source (biomass, waste, coal, oil, NG, etc.) and composition (CO<sub>2</sub> content typically 2 to 30 %), as long as the flue gas has been properly cleaned upstream.
- Possibility to heat integrate with steam cycle and district heating network (reduce OPEX and production loss). Both concerning heating and cooling requirement of the CC process.
- Bypass mode is possible (i.e. low risk for primary plant).
- Expected flexible with respect to load changes, however, this is yet to be demonstrated at scale

### Disadvantages:

- Although the amine-based process is the only CC technology with full-scale references for post-combustion application, there are only few build projects. The shortage in references and underperformance of the few existing full-scale plants create technical uncertainty.
- Requires high standards for upstream flue gas cleaning (low concentration of SO<sub>x</sub>, NO<sub>x</sub>, HCl, particulates) to avoid operational issues. Typically, a pre-scrubber is required in addition to already existing flue gas cleaning, like deNO<sub>x</sub>, particle removal, and desulfurization.
- Emission of amine and amine degradation products must be tightly controlled to avoid emission of environmental harmful compounds.
- High energy demand for thermal regeneration of amine solution and high power consumption for the full CO<sub>2</sub> plant.

### Environmental

Some of the amines applied in CC processes may be harmful to the environment due to high pH, low biodegradability, toxicity, and secondary reactions such as reactions with NO<sub>x</sub> to form harmful nitrosamines. [29]

Emissions of amine and amine degradation products to air with the treated flue gas is the largest environmental concern with amine CC technology. Reducing emissions has been a focus point in recent years R&D work. This has resulted in improved emission control technology and today several vendors claim low emissions of harmful components. [14,15]

Most amine CC processes will not have emissions to water (only from pre-cooling of flue gas) from the amine loop. Risk of spillage and leakage of amine solution from the rather large hold-up in the process needs to be mitigated in the design as many of the used amine chemicals may have low biodegradability.

The consumption of amine due to degradation may also be significant for some amines, in particular monoethanolamine (MEA). This will in turn generate substantial amounts of chemical waste for disposal/incineration (0.2-1 kg/ton CO<sub>2</sub>).

Finally, the significant energy consumption of the CC technology has an indirect environmental impact.

### Research and development perspectives

Over the past couple of decades, a lot of research has been conducted concerning development of new improved amine solvents which require less energy for regeneration, have higher cyclic capacity (smaller equipment), are more resistant to degradation, have better environmental properties, etc. The energy consumption and chemical consumption of the amine CC process have also decreased with nowadays advanced solvents and amine processes yet it is still considerable. Development of amine processes and solvents which are heat-resistant and thereby can provide a CO<sub>2</sub> stream at higher pressure i.e. saving expensive compression work/cost, is also underway [30]. It is likely that amine solvents with even better performance and properties may be identified, however further refinements are unlikely to provide a step change in terms of the energy consumption. Research is also being conducted into radically other kinds of solvents e.g. non-aqueous solvents, special engineered compounds, etc. which may provide a breakthrough in the future in terms of reducing energy consumption. However, this is very uncertain at present.

Also, more advanced process flowsheets with higher extent of heat integration have been developed, which reduces the energy requirement of CO<sub>2</sub> capture. Some suppliers are starting to implement these solutions in their design e.g. the Petra Nova plant by MHI.

On the integration side between the CC plant and the energy plant research is also ongoing. The availability of increasingly sophisticated heat pump technology may improve total energy efficiency of an integrated CC solution, where waste heat can be exploited to a greater extent.

Process equipment suppliers are also starting to develop optimised solutions for CC e.g. Sulzer Chemtech has developed optimized absorber packing for CC. The potential here for CAPEX reductions is likely to be significant in the mid- to long-term as the suppliers are still reluctant to invest in improvements because the large-scale CC market is yet to take off.

### Examples of planned and operating large-scale plants

Work on scale-up and improvement of amine based CC technology gained momentum during mid 2000s due to the growing commercial interest for CC. Several technology vendors (GE, Cansolv/Shell, Aker Solutions, MHI, Hitachi, Fluor, Linde/BASF, etc.) have erected large scale pilot plants in conjunction with power plants and demonstrated their technology's application for post combustion CC. A few vendors have also delivered commercial plants for CO<sub>2</sub> utilisation in the petrochemical industry.

Below is listed some of the main amine-based CC demo plants that have been erected, or projects which have reached the final investment decision stage and will start operation within the next few years. The Global Carbon Capture Institute also publishes annual status reports on CCS projects which provides an overview of projects (not limited to amine CC technology) [31].

- Boundary Dam 1 Mtpa CO<sub>2</sub> capture demonstration plant, Canada (operational 2014 - present), partly financed by public funding [32]. First full-scale post combustion amine plant retrofitted to a commercial operating boiler. The CO<sub>2</sub> is sold for enhanced oil recovery. The plant is based on Shell's Cansolv process and designed for 90% capture from a refurbished 150 MWe coal-fired unit at Saskpower's Boundary Dam power station. The CO<sub>2</sub> is compressed and transported in pipeline to a nearby oil field. The project claimed negative media coverage from cost overruns and delays [33]. Following start-up, the plant suffered some issues with fly ash deposition and plugging of equipment as well as excessive amine degradation, and foaming issues, which have taken years to fix.[34] Quarterly updates of plant performance are published by SaskPower showing that improvements are still being made to achieve the desired plant performance and availability.[35] By end of 2022, the plant reached a milestone of 5 million tons CO<sub>2</sub> captured, which is around 50% below the design value since start-up in 2014.[36]

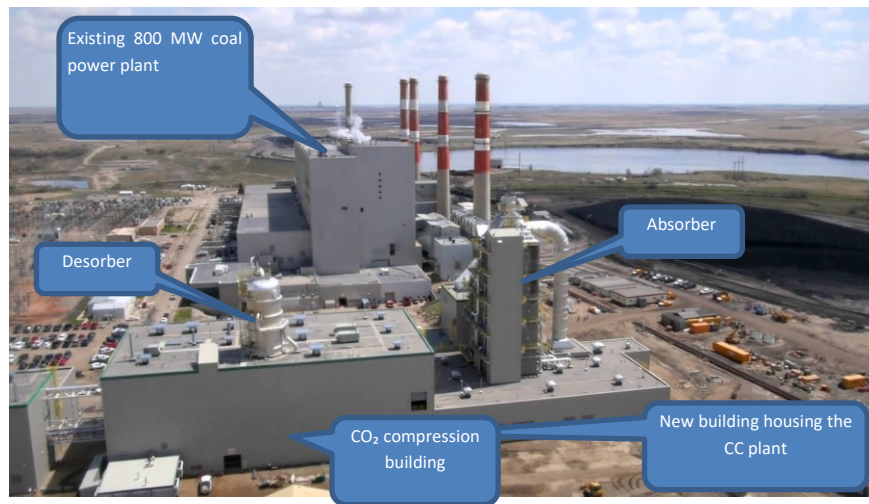

**Figure 13.** Photo [37] of Saskpower 800 MW<sub>e</sub> Boundary Dam coal-fired power station where one of the four units was retrofitted with amine CC in 2013.

- Petra Nova, 1.6 Mtpa CO<sub>2</sub> capture demonstration plant, USA (operational 2016-2020). The amine plant was designed to capture 90% of CO<sub>2</sub> from a 240 MW slipstream of flue gas from the coal-fired W.A. Parish Unit 8 Generating Station. This was the world's largest amine based capture plant at the time of inception. The CO<sub>2</sub> was compressed and transported by pipeline to a nearby oil field where it was sold for EOR. The CC technology was provided by MHI. Separate heat recovery boilers fitted to a gas turbine supplied the heat to the capture plant. MHI implemented novel heat integration in the CC process to obtain low energy numbers. The plant was delivered on budget and schedule [38]. The first million-ton CO<sub>2</sub> was captured 10 months after commencement of commercial operation and in Dec. 2019 (3 years anniversary) 3.5 million metric tons CO<sub>2</sub> had been captured. This was somewhat below the target capacity (17%). The reasons for being below target are partly related to outages of steam plant and other balance of plant systems as well as the load factor of the coal power station. The CC plant experienced similar issues as the Boundary Dam plant including flue gas depositions and equipment scaling. The observation highlights the need for proper flue gas cleaning upstream a CC plant to achieve reliable operation. The Petra Nova plant was mothballed in 2020 due to low offtake price/volume of CO<sub>2</sub> following the collapse in crude oil price [39]. Recently, it has been claimed that the plant performance was likely worse than indicated in the preceding, with the CC plant failing to deliver both 90% capture and the promised operation time [40].



Figure 14. Petra Nova amine CC plant retrofitted to a slip stream of flue gas (equivalent to 240 MWe) from the WA Parish unit 8 coal-fired power plant. [41]

- Technology Centre Mongstad (TCM), Norway (operational 2012-present). Large pilot facility established next to the Equinor's Mongstad refinery. The test facility operates an 80.000 tpa amine CC plant delivered by Aker Solutions and a 40.000 tpa sized Chilled Ammonia Plant delivered by ALSTOM (now Baker Hughes). The captured CO<sub>2</sub> is not used but released back to the atmosphere. Originally CO<sub>2</sub> could be captured from two different sources a) natural gas combined cycle CHP and b) a fluidized catalytic cracker (FCC). The amine plant has been used by several vendors (Aker Solutions [14], Shell, Carbon Clean Solutions, ION Engineering and Fluor corp.) to test and qualify their technology in semi-commercial scale. The chilled ammonia plant was only operated for test campaigns during 2012-2014 and has since been out of operation.

Several amine CC plants are also in the planning in Europe. The Norwegian national CCS demonstration project has the aim to realise a full CC, transport, and storage value chain. FEED studies have been conducted for two CO<sub>2</sub> capture projects both based on retrofit of amine CC plants, which are currently under construction:

- 400,000 tpa CO<sub>2</sub> capture from Norcem's cement plant in Brevik, Norway. The project includes waste heat recovery and heat integration with the cement plant as well as CO<sub>2</sub> liquefaction plant and liquid CO<sub>2</sub> export terminal. The 400.000 tpa constitutes approximately half of the total CO<sub>2</sub> emission from the cement kiln. This is evaluated to be the maximum feasible CO<sub>2</sub> capture capacity as the plant is solely to be driven by waste heat from the cement kiln and the CO<sub>2</sub> compressor. The technology provider for the amine capture plant is Aker Solutions. [42]
- Approx. 400,000 tpa CO<sub>2</sub> capture from Waste to Energy plant at Klemetsrud, Oslo. The project includes heat integration with WtE plant and upgrade of low-grade heat to district heating (compensate for heat loss with CC). The project also includes CO<sub>2</sub> liquefaction plant as well as 10 km truck/pipeline transport of CO<sub>2</sub> to CO<sub>2</sub> export terminal at harbour. The technology provider for the amine capture plant is Shell Cansolv. [43]

The “Ørsted Kalundborg Hub”, Ørsted’s CO<sub>2</sub> capture and storage project, has now entered a 20 year contract with the Danish Energy Agency to capture 150 ktons/year of biogenic CO<sub>2</sub> from the straw fired Avedøre power plant and 280 ktons/year of biogenic CO<sub>2</sub> from the wood chip fired Asnæs power plant.[44, 45] The captured CO<sub>2</sub> will be transported by truck to the Asnæs power plant; the hub for interim CO<sub>2</sub> storage for both power plants, and the gateway to onward transport to the Northern Lights reservoir in the North Sea (Norwegian). Construction is anticipated to start in June 2023, with capture operations commencing 2026.

In the Netherlands two medium scale CC and utilisation projects are in construction/planning based on amine CC from WtE plants and CO<sub>2</sub> use for greenhouse fertilization. Dutch WtE company AVR has completed construction of 60,000 tpa amine based capture and liquefaction plant [46] at their Duden site. Dutch WtE company Twence has begun construction at their Hengelo facility, where the “Just Catch” amine CC technology developed by Aker will be implemented.[47,48] The facility is anticipated to be operational in late 2023, where the plant has the potential to capture 100k t CO<sub>2</sub>/year at a CO<sub>2</sub> stream purity of >99.9% for reuse in greenhouse horticulture, the food and beverage industry, chemicals industry, biofuel production *etc.* Furthermore, the project Porthos aims to establish a large CCUS hub around the Rotterdam harbour area with the final investment decision to be made in 2023. [49] It is expected that 2.5 MTPA CO<sub>2</sub> per year will be captured from several industrial sites in the area and transported by pipeline (30 km, 35 bar, 108 cm) to a compressor station at Maasvlakte. Onward transport will also be by pipeline (22km, 130 bar, 40 cm) to the final storage location; P18-A, a former oil and gas platform, where the CO<sub>2</sub> will be injected in to the injection wells in the North Sea and continuously monitored. Construction is expected to begin 2023/2024 and operational in 2026.

In the UK several large-scale CCS demonstration projects have been far in the planning but they have all been cancelled for financial reasons. More recently Drax Power Station has installed a pilot plant to capture CO<sub>2</sub> from a biomass fired unit (BECCS) and plans exist to build full-scale facility at one of the units at Drax by 2027 [50]. In late 2022, Drax also made an agreement with Respira in the USA, to stimulate the implementation of their BECCS technology, securing carbon dioxide removals certificates for Respira totalling 2 million metric tons of CO<sub>2</sub> over a 5 year period.[51] Operation at Tata Chemicals Europe’s first industrial scale CC plant in the UK began in mid 2021, and reported capture of >40 ktons of CO<sub>2</sub> in the first year of operation.[52,53, ] The captured CO<sub>2</sub> is classified as food and pharmaceutical grade, and is used specifically for medical grade sodium bicarbonate (Ecokarb®) production.

### Prediction of performance and costs

#### CAPEX

The total capital cost of retrofitting an amine unit to an existing emission point source will, in addition to the cost of the CC plant itself, consist of various integration costs. The integration costs are substantial and may vary significantly from case to case depending on the scope included. The following typical cost elements may be included in retrofit projects in addition to the CC plant costs:

- Boiler for generating low pressure steam to CC plant or modification of steam turbine/new steam turbine to allow for steam extraction to CC plant.
- CO<sub>2</sub> compression and dehydration or CO<sub>2</sub> liquefaction plant.
- Liquid CO<sub>2</sub> tank farm (interim storage) and CO<sub>2</sub> export facilities.
- Extensive heat integration, e.g., heat pumps.
- Additional flue gas cleaning e.g. desulfurization plant.
- Utilities such as cooling tower, water treatment plant, etc.
- New buildings for CC plant.
- Reconstruction and/or demolition work to acquire space for CC installation.
- Owner's cost, contingency.

As a result of differences in scope and the general uncertainty on cost estimation, significant scatter is seen in CAPEX estimates reported in the literature for retrofit cases. Moreover, since only few CC projects have been realised, there is a general lack of as-built capital cost data.



Table 9 includes the publicly available cost data for the two existing large-scale post combustion retrofit projects Boundary Dam and Petra Nova. To supplement, recent cost estimates for a retrofit case study for Saskpower's Shand power plant and the Norwegian National CCS Demonstration project are also included. For these projects, the cost data is based on significant level of engineering and therefore of higher credibility than miscellaneous high-level studies in the literature.

As shown in Table 9, the scope included in the capital cost is not identical. All cases however include costs for integration and CO<sub>2</sub> compression/liquefaction, which are major add-ons. Total actual cost of the Boundary Dam project has been reported to 1.5 billion USD, but about half of this was related to refurbishing of old coal-fired boiler including new turbine and generator as well as an amine-based desulphurisation plant. The Petra Nova total actual project cost has been reported to about 1 billion USD, which is more than the predicted engineering cost. The cost also included utilities and a steam plant. The Norwegian projects include CO<sub>2</sub> liquefaction and liquid CO<sub>2</sub> storage tanks as well as CO<sub>2</sub> export pier, which is more costly than CO<sub>2</sub> compression for pipeline transport. Also, the Norwegian projects included extensive heat integration with heat pumps and waste heat recovery units.

To obtain a more equal basis for the CAPEX it has been adjusted across projects. The CAPEX reported for CC retrofit will then include CO<sub>2</sub> capture plant, CO<sub>2</sub> liquefaction, utility systems (cooling water, electricity, steam, etc.), integration costs (hook-up to main plant) and owner's cost.

**Table 9. Example costs of specific amine CC retrofit projects based on engineering estimates or actual costs.**

Project	Boundary Dam	Petra Nova	Shand feasibility study	Klemetsrud CCS	Norcem CCS
<b>Project type</b>	Commercial plant in operation	Mothballed commercial plant	Feasibility study	Construction started	Construction started
<b>Emission source</b>	Coal-fired power plant	Coal-fired power plant	Coal-fired power plant	Waste to Energy	Cement kiln
<b>CO<sub>2</sub> use</b>	Enhanced oil recovery	Enhanced oil recovery	Enhanced oil recovery	Storage	Storage
<b>Capacity (t CO<sub>2</sub> output/h)</b>	135	200	272	52	55
<b>Scope included in CAPEX besides capture plant</b>	CO <sub>2</sub> Compression, stretch of pipeline	CO <sub>2</sub> Compression, steam plant, cooling tower	CO <sub>2</sub> Compression plant	Liquefaction, 4 days storage, export of CO <sub>2</sub> to harbor, harbor export facilities, heat integration and heat pumps, host modification	Liquefaction, 4 days storage, export of CO <sub>2</sub> , heat integration, host modifications
<b>Adjusted CAPEX in 2020-EUR*</b>	780 mill EUR	630 mill EUR	810 mill EUR	310 mill EUR	390 mill EUR
<b>Specific CAPEX (mill EUR/[t CO<sub>2</sub> output/h])</b>	5.8	3.6	3.0	6.2	7.7

Reference	[33]	[54]	[55]	[42, 56, 57]	[42, 56,57,58]
-----------	------	------	------	--------------	----------------

\*Adjusted to scope (CC plant including liquefaction, and integration but excluding heat pumps, pipelines or export/interim storage facilities). Adjusted with exchange rates from EUROSTAT and the Danish consumer price index from Statistics Denmark to 2020-price level.

Other studies which have been included in Figure 15 include ION, [59] and San Juan [60], which are CC plants retrofitted to coal-fired power plants in the USA, Peterhead CC from an existing combined cycle gas turbine in Scotland [61] and Lehigh CC on a cement facility in Canada [62]. Again, project scopes differ between projects because of different CO<sub>2</sub> application, level of heat integration, ect. To enable comparison between projects, scope has been adjusted to include CC, CO<sub>2</sub> liquefaction, and integration/utility system. The related CAPEX adjustments are based on high-level estimates of the individual process components (Figure 15). Scope adjustment gives rise to some level of uncertainty in CAPEX estimate.

Rubin et al. compared [63] cost estimates of 6 different case studies for new built coal fired power plants (capacity 1-4 MTPA, generic cases) with amine CC and found that the specific CAPEX varied from 1600 to 2300 USD/kWe generating capacity, which translates to approximately 2.1-2.9 mill EUR/(t CO<sub>2</sub> output/h)[64]. This is lower than any of the cases reported in Table 9, but the capture capacity is significantly higher, and the case covers newbuilt plants.

The Global CCS Institute released an update on its predicted global cost of CC in 2017 [65]. This provided estimates on cost of CC implemented in different industries. For coal fired boilers, specific capital costs of 1.6 mill EUR/(t CO<sub>2</sub> output/h) for CC installation can be deduced. This includes compression and transport of CO<sub>2</sub> and is related to newbuilt power station in USA with capacity of 480-550 t CO<sub>2</sub> output/h.

It is clear from the above-referenced studies that many desktop studies of generic plants provide substantially lower CAPEX estimates compared to specific projects where the costs are based on some level of engineering. Also, the fact that most desktop studies concern newbuilt facilities will contribute to significantly reduced integration costs.

Figure 15 shows a comparison of the different CAPEX estimates in Table 9 and in the referenced studies as a function of the CC plant installed capacity. It is apparent that the effect of scale on specific CAPEX shown is quite pronounced. However, it is also clear from the scatter in Figure 15 that the CAPEX of CC retrofit project is difficult to generalise and there will be considerable uncertainty on such generalised cost estimates. The CAPEX estimates for 2020 in the Data Sheets are based on the cost level indicated in Figure 15. The Global CCS Institute reports a similar positive influence of plant scale but expects the specific costs reductions to level off at capacities above ~40 ton/h [66]. This expectation is based on theoretical studies but does not seem consistent with the first plants planned/studied (Figure 15). However, the data and trend curve in Figure 15 is not free from bias, as the most expensive projects in terms of cost per ton of CO<sub>2</sub> are likely the first project being built, and first-build projects are generally related to higher costs.



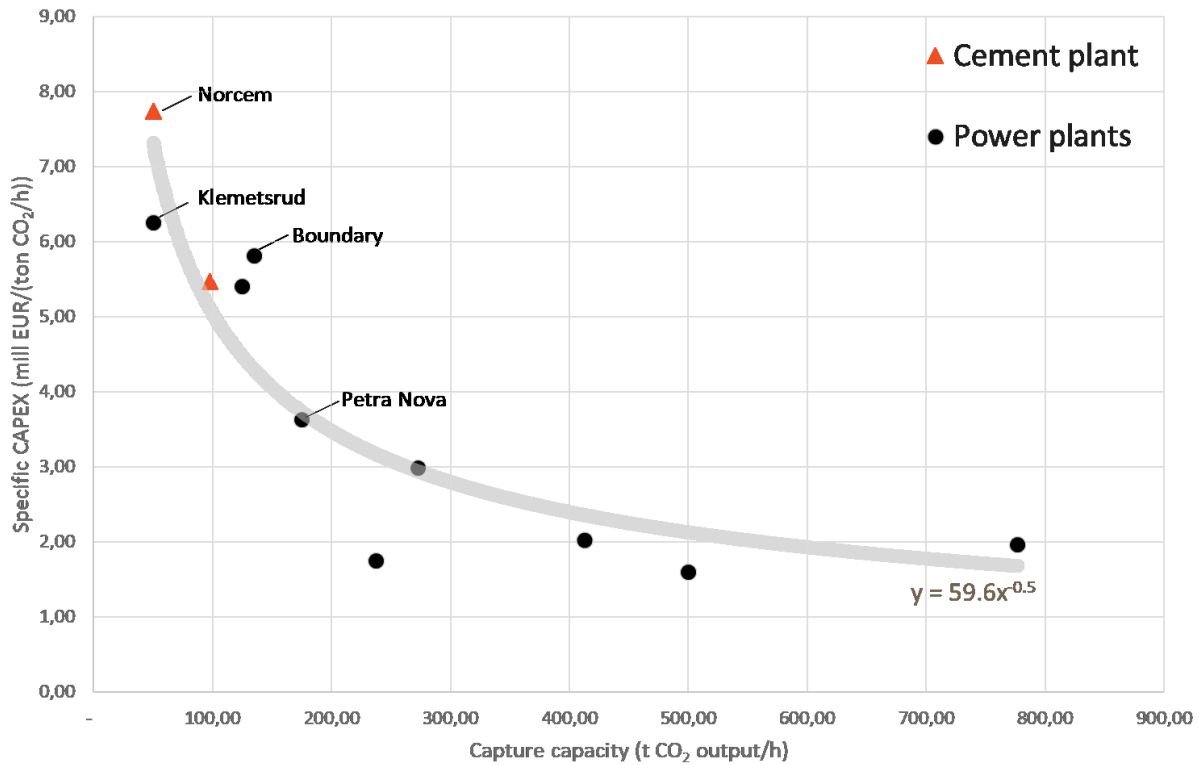

Figure 15. Specific CAPEX cost of complete CC plant installations including CO<sub>2</sub> liquefaction, integration and utility costs vs. CC plant capacity (data from Table 9 and other projects). The scope of the actual projects differs but have been aligned for the present analysis. CAPEX has been adjusted according to the technical adjustments based on high level estimates of process components. Build and *in progress* projects are indicated, while the remaining data points are from design studies.

Figure 16 shows a rough estimate of the share of total CAPEX for a retrofit CC project that is related to respectively the capture plant, utilities incl. flue gas supply, CO<sub>2</sub> compression, Owner's cost and heat integration e.g. turbine refurbishment, steam plant and waste heat recovery. The estimate is amongst other based on data from [67]. Figure 16 can be used to correct the CAPEX estimate if not all scope is relevant to the investigated CC project.

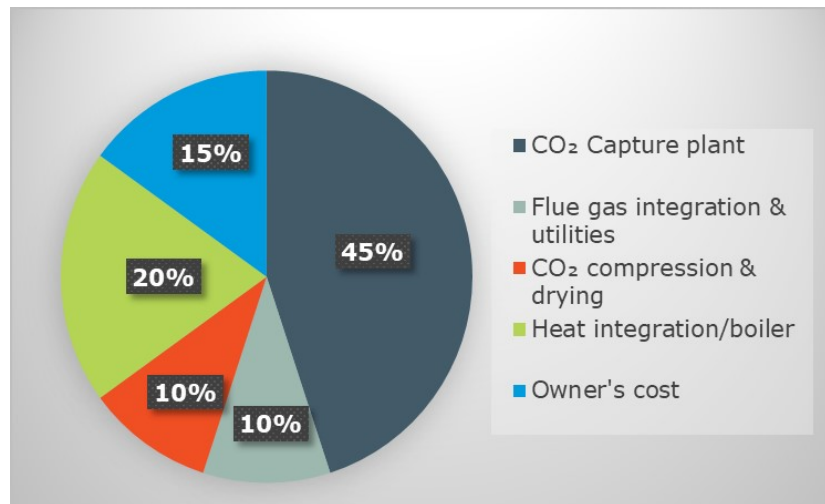

Figure 16. Estimated CAPEX distribution of a complete CC plant retrofit installation based on data from [67].

### OPEX

Fixed O&M for amine CC includes staffing, maintenance, service agreements. As the amine CC plant will be an add-on to an existing facility, the need for additional operating staff is reduced. 7 to 15 additional staff (depending on size and the site's existing organisation) for O&M is expected for a commercial plant including CO<sub>2</sub> compression and drying. Other fixed O&M such as service agreements and maintenance. Annual fixed O&M is calculated as 3% of CAPEX.

Variable OPEX for amine CC plants are dominated by cost of heat and electricity. Many reported variable OPEX in the literature includes cost of energy. Excluding heat and electricity (listed separately) the variable OPEX is mainly related to costs of make-up of amine, caustic soda for flue gas pre-treatment, waste disposal costs and the variable part of maintenance costs.

The cost of make-up amine may range from 1.5-12 EUR/kg depending on the specific amines applied. The consumption rate is as provided in Table 6. Based on this, a cost of 2 EUR/(t CO<sub>2</sub>) is included in variable O&M.

Other consumables such as caustic soda, activated carbon, etc. are required in minor quantities. These consumables will typically constitute less than 1% of OPEX. Disposal cost of chemical waste from reclaimer is typically also comparatively small. A cost of 0.5 EUR/(t CO<sub>2</sub>) is included in variable O&M to cover all these small consumables.

### Learning curves and technological maturity

The amine-based CC technology has been deployed in chemical industries for a long time and also been deployed at full-scale power plants for post-combustion CC, making it widely considered as a fully commercial process (TRL 9) [25]. However, it can be questioned whether amine CC as a generalized technology group can be considered fully commercial for post-combustion application at the scale of typical power or cement plants.

First, there are only few vendors with experience from building and operating full scale post-combustion plants (cf. *Examples of planned and operating large-scale plants*). Secondly, these full-scale plants have generally underperformed. As the Boundary Dam and Petra Nova projects exemplify, every technology provider can be expected to run into different teething troubles in their initial projects and they will have to learn from these first to provide better and more cost-effective projects in the future.

Based on the literature, an average cost reduction of 10% is expected when the installed capacity doubles [68]. The International Energy Agency and International Energy Forum have analysed the needed capacities that need to be installed in 2030 and 2050 to reach the climate goals in the Paris Agreement. The installed capacity in 2020 was 40 MTPA. The installed

capacity has to increase to 1,300 MTPA until 2030 and 5,600 MTPA until 2050. This corresponds to an expected cost reduction of 55% between 2020 and 2050.

### Uncertainty

Compared to the first edition of the present Technology Catalogue, the CAPEX estimates have increased for all cases in the Data Sheet. Part of the increase is explained by a change in scope from CO<sub>2</sub> compression to CO<sub>2</sub> liquefaction, reflecting typical Scandinavian project scope. The CAPEX increase is also influenced by inclusion of more references in the underlying data set (Figure 15) and further project maturation of the Norwegian projects at Klemetsrud and Norcem, where project costs have increased significantly. The limited number of project references, especially erected plants, give rise to large uncertainty on cost data for full-scale post-combustion CC plants.

The cost development for the Norwegian Longship project highlights that a large contingency cost must be included for retrofit projects at this early phase of technology implementation. Both Norwegian projects (Klemetsrud and Norcem) have experienced high cost overrun after the final investment decision was taken. The CCS project at Klemetsrud waste-to-energy plant was consequently paused during 2023 to reduce project costs, delaying the commercial operation date by a minimum of one year to 2027 [69]. The cost development in both projects reflect the large uncertainty related to being among the first projects of their kind project. Besides inflation and currency devaluation, other factors including demolition, demand for larger plot areas than expected, shortage in power supply, and re-location of export facilities have added to the cost [70].

In a 2050 perspective there will be significant uncertainty predicting the performance and cost of technology as it will depend on how and when the market will develop. As the cost data at 2020 level is based on first-of-a-kind plants, it is however likely that costs will decrease substantially in the future due to technology improvements, construction of newbuilt plants rather than retrofits, increased production capacity and general market competition. Breakthrough of the CCS industry seems highly dependent on successful execution of the publicly supported CCS projects in e.g., Norway and Denmark, and a parallel development in CO<sub>2</sub> cost/value to ensure the necessary long-term viability of the CO<sub>2</sub> capture industry. Successful execution of upcoming projects also seems important to maintain technical confidence in post-combustion CC technology at this scale, since the first full-scale projects at Boundary Dam and Petra Nova did not meet expected performance.

### Quantitative description

Three data sheets have been provided for amine based CC technology (separate Excel file). The sheets cover the following emission sources and capacities:

- CC plant (32 t CO<sub>2</sub>/h) retrofit to 100 MW<sub>th</sub> waste or biomass fired CHP
- CC plant (164 t CO<sub>2</sub>/h) retrofit to 500 MW<sub>th</sub> biomass fired CHP
- CC plant (152 t CO<sub>2</sub>/h) retrofit to 4500 tpd clinker cement kiln

### References

---

- [10] Northern Lights signed agreement with Ørsted - Fullskala (ccsnorway.com)
- [11] The Longship CCS project in Norway | Learn more about the project (ccsnorway.com)
- [12] T. Wang, J. Hovland, K. J. Jens. Amine reclaiming technologies in post-combustion carbon dioxide capture. *J. Environmental Sciences*, 27 (2015), 276-289.
- [13] Y. L. Moullec, T. Neveux, A. Al Azki, A. Chikukwa, K. A. Hoff. *Energy Procedia* 63 ( 2014 ) 1470 – 1477.
- [14] Gorset, O., Knudsen, J.N., Bade, O.M., Askestad, I. Results from testing of Aker Solutions advanced amine solvents at CO<sub>2</sub> Technology Centre Mongstad. *Energy Procedia*. Vol 63, 2014, Pages 6267-6280.
- [15] MHI's Energy Efficient Flue Gas CO<sub>2</sub> Capture Technology and Large Scale CCS Demonstration Test at Coal-fired Power Plants in USA. *Mitsubishi Heavy Industries Technical Review* Vol. 48 No. 1 (March 2011)

- [16] J. N. Knudsen, J. Andersen, J. N. Jensen, O. Biede. Evaluation of process upgrades and novel solvents for the post combustion CO<sub>2</sub> capture process in pilot-scale. *Energy Procedia* 4 (2011) 1558–1565.
- [17] Leila Faramarzi et al. Results from MEA testing at the CO<sub>2</sub> Technology Centre Mongstad: Verification of baseline results in 2015. *Energy Procedia* 114 (2017) 1128 – 1145.
- [18] Luna-Ortiz, Eduardo, Yao, Cathy, Barnes, Jon, Winter, Matthew, and Matthew Healey. "Development of A CO<sub>2</sub> Specification for Industrial CCS Transport Networks: Methodology, Limitations and Opportunities." Paper presented at the Offshore Technology Conference, Houston, Texas, USA, May 2022. doi: <https://doi.org/10.4043/32103-MS>
- [19] Satish Reddy, Jeffrey R. Scherffius, Joseph Yonkoski, Peter Radgen, Helmut Rode, Initial Results from Fluor's CO<sub>2</sub> Capture Demonstration Plant Using Econamine FG PlusSM Technology at E.ON Kraftwerke's Wilhelmshaven Power Plant, *Energy Procedia*, Volume 37, 2013, 6216-6225
- [20] Rochelle, G. (2009). Amine Scrubbing for CO<sub>2</sub> Capture. In *Science* (Vol 325), p. 1652-1654.
- [21] Udara S.P.R. Arachchige, Dinesh Kawan, Lars-André Tokheim, and Morten C. Melaen, Model Development for CO<sub>2</sub> Capture in the Cement Industry, *Intl. J. of Modelling and Optimization*, 3(6), 2013.
- [22] Adewale Aeosun, Mohamman, R.M. Abu-Zahra, Evaluation of amine-blend solvent systems for CO<sub>2</sub> post-combustion capture applications, *Energy Procedia*, 37, 211-218, 2013
- [23] Bui et al., 2020, Demonstration flexible operation of the Technology Centre Mongstad (TCM) CO<sub>2</sub> capture plant. In: *International Journal of Greenhouse Gas Control* 93 (102879).
- [24] Montañés et al., 2018, Experimental results of transient testing at the amine plant at Technology Centre Mongstad: Open-loop responses and performance of decentralized control structures for load changes. In: *International Journal of Greenhouse Gas Control* 73, p. 42-59.
- [25] Kearns et al. (2021). Technology Readiness and Costs of CCS. The Global CCS Institute. URL: [Technology-Readiness-and-Costs-for-CCS-2021-1.pdf](https://www.globalccsinstitute.com/resources/technology-readiness-and-costs-for-ccs-2021-1.pdf) (globalccsinstitute.com)
- [26] Ugochukwu et al. (2011). Solubility of CO<sub>2</sub> in 15, 30, 45 and 60 mass% MEA from 40 to 120 C and model representation using the extended UNIQUAC framework. In: *Chemical Engineering Science* (66), p. 6393-6406.
- [27] Rezazadeh et al. (2017). Effectiveness of absorber intercooling for CO<sub>2</sub> absorption from natural gas fired flue gases using monoethanolamine solvent. In: *International Journal of Greenhouse Gas Control* (58), p. 246-255.
- [28] Satish Reddy, Jeffrey R. Scherffius, Joseph Yonkoski, Peter Radgen, Helmut Rode, Initial Results from Fluor's CO<sub>2</sub> Capture Demonstration Plant Using Econamine FG PlusSM Technology at E.ON Kraftwerke's Wilhelmshaven Power Plant, *Energy Procedia*, 37, 2013, 6216-6225, ISSN 1876-6102, <https://doi.org/10.1016/j.egypro.2013.06.550>
- [29] Review of amine emissions from carbon capture systems. SEPA (Scottish Environmental Protection Agency) report, Version 2.01, August 2015.
- [30] Y.-J. Lin, G. T. Rochelle. Optimization of Advanced Flash Stripper for CO<sub>2</sub> Capture using Piperazine. *Energy Procedia*, 63 (2014), 1504 – 1513.
- [31] Global Status of CCS 2022 - Global CCS Institute; <https://www.globalccsinstitute.com/resources/global-status-report/>
- [32] Carbon Capture and Sequestration Technologies @ MIT
- [33] MIT Boundary Dam Fact Sheet: Carbon Dioxide Capture and Storage Project. Available at [https://sequestration.mit.edu/tools/projects/boundary\\_dam.html](https://sequestration.mit.edu/tools/projects/boundary_dam.html)
- [34] Giannaris, S. 2021. SaskPower's Boundary Dam Unit 3 Carbon Capture Facility - The Journey to Achieving Reliability. 15th International Conference on Greenhouse Gas Control Technologies, GHGT-15
- [35] [https://www.saskpower.com/Our-Power-Future/Our-Electricity/Electrical-System/System-Map/~/\\_link.aspx?\\_id=3824E908B8754F559EFE5AB92AE9DD7C&\\_z=z](https://www.saskpower.com/Our-Power-Future/Our-Electricity/Electrical-System/System-Map/~/_link.aspx?_id=3824E908B8754F559EFE5AB92AE9DD7C&_z=z)
- [28] <https://www.saskpower.com/about-us/our-company/blog/2023/bd3-status-update-q4-202236>
- [37] [https://www.google.com/search?q=boundary+dam+carbon+capture&source=lnms&tbm=isch&sa=X&ved=2ahUKewj\\_18TUppHqAhUMKewKHYhKCLEQ\\_AUoAX-oECAwQAw&biw=1536&bih=722&safe=active&ssui=on#imgcr=3pdvE8jQhi\\_-eM&imgdii=mO3vqffuRGTFzM](https://www.google.com/search?q=boundary+dam+carbon+capture&source=lnms&tbm=isch&sa=X&ved=2ahUKewj_18TUppHqAhUMKewKHYhKCLEQ_AUoAX-oECAwQAw&biw=1536&bih=722&safe=active&ssui=on#imgcr=3pdvE8jQhi_-eM&imgdii=mO3vqffuRGTFzM)
- [38] W.A. Parish Post-Combustion CO<sub>2</sub> capture and sequestration project. Final Public Design Report. Award No. DE-FE0003311. DOE. by Petra Nova Parish Holdings LLC.
- [39] Dennis Warmsted, Petra Nova Mothballing Post-Mortem, August 2020, [www.iefef.org](http://www.iefef.org).
- [40] [The ill-fated Petra Nova CCS project: NRG Energy throws in the towel | IEEFA](#)
- [41] Welcome to NRG | NRG Energy

- [42] Norsk CCS Demonstrasjonsprosjekt Norcem Konsept og Forprosjekt. Norcem DG2 rapport. Doc. no. NC02-NOCE-A-RA-0011 VASKET. 08-11-2017.
- [43] Fortum Oslo Varme Carbon Capture Oslo. Concept Study Report. doc. no. NC02-KEA-A-RA-0002.
- [44] Ørsted, Aker Carbon Capture, and Microsoft commit to explore development of carbon capture (orsted.com)
- [45] Ørsted awarded contract – will capture and store 430,000 tonnes of biogenic CO<sub>2</sub> (orsted.com)
- [46] Greenhouse Helps Dutch Waste to Energy Facility Cut CO<sub>2</sub> Emissions by 15%. Waste Management World, 2019-11-05. Process Modifications for Solvent-Based Post Combustion CO<sub>2</sub> Capture.
- [47] Twence - Twence CO<sub>2</sub> capture plant In Hengelo sets an example for the...
- [48] Just Catch™ – Aker Carbon Capture
- [49] Project - Porthos (porthosCO<sub>2</sub>.nl)
- [50] Drax Power BECCS: <https://www.drax.com/about-us/our-projects/bioenergy-carbon-capture-use-and-storage-beccs/>
- [51] World's biggest carbon removals deal announced at New York Climate Week - Drax US
- [52] Tata Chemicals Europe Opens UK's Largest Carbon Capture Plant | [www.tatachemicalseurope.com](http://www.tatachemicalseurope.com)
- [53] Carbon Capture & Utilisation | [www.tatachemicalseurope.com](http://www.tatachemicalseurope.com)
- [54] W.A. Parish Post-Combustion CO<sub>2</sub> capture and sequestration project. Final Public Design Report. Award No. DE-FE0003311. DOE. by Petra Nova Parish Holdings LLC.
- [55] The Shand CCS Feasibility Study Public Report. International CCS Knowledge Centre. November 2018.
- [56] Prop. 118 S (2022–2023) (regjeringen.no) p177/390
- [57] Kvalitetssikring (KS2) av demonstrasjon av fullskala fangst, transport og lagring av CO<sub>2</sub> - Tilleggsvurdering fase 2. Oslo economics og ATKINS, 28. juni 2018.
- [58] CO<sub>2</sub>-fangstanlegg sprekker med nær én milliard – E24
- [59] [https://netl.doe.gov/sites/default/files/netl-file/21CMOG\\_CCUS\\_Awtry.pdf](https://netl.doe.gov/sites/default/files/netl-file/21CMOG_CCUS_Awtry.pdf)
- [60] <https://www.osti.gov/biblio/1889997>
- [61] Peterhead CCS Project, Cost Estimate Project 2016 by Shell
- [62] Leigh Cement Edemontton CCUS feasibility project, 2021
- [63] Rubin, Edward S., John E. Davison, and Howard J. Herzog. "The cost of CO<sub>2</sub> capture and storage." International Journal of Greenhouse gas control 40 (2015): 378-400.
- [64] E. S. Rubin, J. E. Davison, H. J. Herzog. The Cost of CO<sub>2</sub> capture and storage. Int. J. of Greenhouse Gas Control. 40 (2015) 378-400.
- [65] I. Lawrence. GLOBAL COSTS OF CARBON CAPTURE AND STORAGE. Global CCS Institute. Cost update report, June 2017.
- [66] [CCe-CCS-Technology-Readiness-and-Costs-22-1.pdf \(globalccsinstitute.com\)](#)
- [67] W.A. Parish Post-Combustion CO<sub>2</sub> capture and sequestration project. Final Public Design Report. Award No. DE-FE0003311. DOE. by Petra Nova Parish Holdings LLC.
- [68] THE NORWEGIAN FULL-SCALE CCS DEMONSTRATION PROJECT Potential for reduced costs for carbon capture, transport and storage value chains (CCS), Gassnova SFReport No.: 2019-1092, Rev. 2, Date: February 28, 2020
- [69] Celsio puts Klemetsrud carbon capture project on hold - Fullskala (ccsnorway.com)
- [70] CO<sub>2</sub>-fangstanlegg sprekker med nær én milliard – E24

## 402 Oxy-fuel combustion technology

### Contact information

- Contact information: Danish Energy Agency: Emil Esketveit Rasmussen emrm@ens.dk; Christoph Wolter chwo@ens.dk.
- Author: Niels Ole Knudsen from COWI

### Brief technology description

#### 1.1 Oxy fuel combustion at Pulverized coal (PC) and Circulating Fluid Bed (CFB) fired units

Oxy-fuel combustion is a relatively new technology. The first proposals for commercial use of the technology originated in 1982 when oxy-fuel combustion was proposed as a technology to provide CO<sub>2</sub> for EOR.

Conventional boilers use atmospheric air for combustion, where the 79% nitrogen in air dilute the CO<sub>2</sub> in the flue gas. To avoid post-combustion carbon capture, nitrogen is removed before combustion, resulting in a flue gas consisting primarily of water vapor and carbon dioxide.

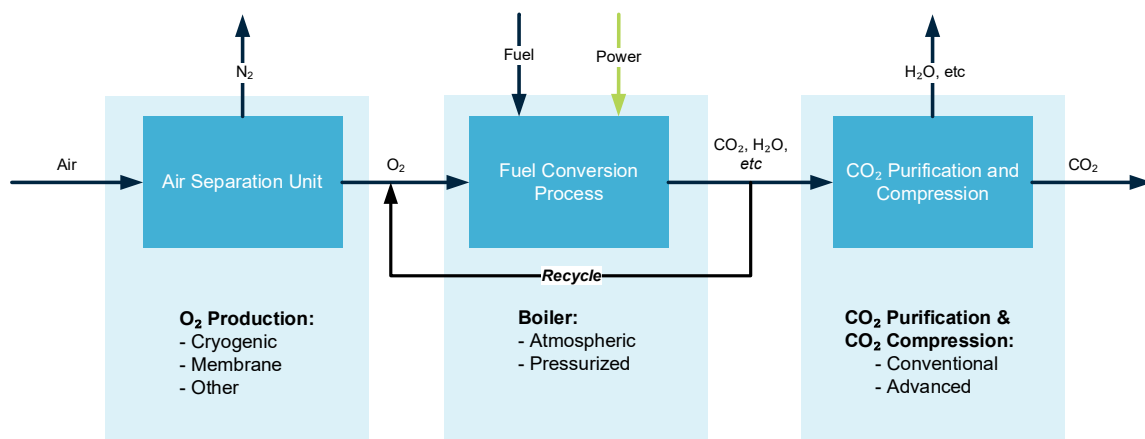

Figure 17 Schematic illustration of oxy-fuel combustion.[1]

In principle, there are only three differences between a conventional power plant and an oxy-fuel power plant

1. An oxygen source typically an air separation unit (ASU)
2. Flue gas recirculation (FGR)
3. CO<sub>2</sub> purification (and compression) (CPU)

Theoretically, the difference between the two combustion concepts seems limited, but as the properties of the gases and the thermodynamic framework conditions change, the combustion zone, heat-transfer, etc. must be adapted accordingly. A primary difference results from the higher heat capacity of H<sub>2</sub>O and CO<sub>2</sub> (with respect to N<sub>2</sub>); the oxygen concentration must be kept at 27-30% instead of the atmospheric 21%, ensuring that the same adiabatic flame temperature is maintained. Consequently, approx. 60% of the flue gas must be recycled as the oxidant is pure oxygen. Additionally, the flow through the boiler after recirculation of flue gas is slightly reduced, while the flue gas flow out of the plant is reduced by approximately 80% as it primarily consists of H<sub>2</sub>O and CO<sub>2</sub>.

The higher thermal radiation of CO<sub>2</sub> and H<sub>2</sub>O (with respect to N<sub>2</sub>) can be managed by keeping the O<sub>2</sub> below 30% in the burners, meaning the heat transfer in the radiation part of the boiler is unchanged and can be maintained. In the convection

part of the boiler, (approximately after the first superheater) thermal transmission is lower, therefore additional (retrofitted) surfaces may be necessary.

The flue-gas outlet from an oxy-fuel boiler consists primarily of CO<sub>2</sub> and H<sub>2</sub>O, but air ingress, necessary O<sub>2</sub> surplus, argon in the O<sub>2</sub>-input stream, nitrogen in the fuel, etc., result in the final dry CO<sub>2</sub> concentration at full load lying between 70-90%; 70% can be reached at PC and CFB retrofit units, and 80-90% at new plants.

Since 2015 R&D at oxyfuel combustion plants have been limited, the main reasons seems to be the increased complexity of operating the additional unit operations especially during start-up and load changes, and a lower than expected purity of the raw CO<sub>2</sub> due to air ingress etc. At cement plants there are still some research ongoing.

### 1.2 Oxy-fuel at grate-fired units

At grate-fired units, air leakages are crippling for use of the oxy-fuel technology. Since grate-fired boilers are small, and notoriously known to leak air at fuel-feeding and ash outlets, etc., it will be very challenging to retrofit an existing grate boiler to oxy-fuel conditions. No demo plants for oxy-fuel firing of grate-fired boilers have been erected. No relevant literature or reports on experimental work for oxy-fuel combustion in grate-fired units exists.

### 1.3 Oxy-fuel firing at cement plants

In cement plants it is possible to obtain a concentrated CO<sub>2</sub> flue gas by oxy-fuel firing as in power plants, however, due to the much more integrated process (calcination, clinker burning, clinker cooling etc.) retrofitting a cement plant is substantially different from retrofitting a power plant.

Around two-thirds of the CO<sub>2</sub> emissions from the cement industry are process related, originating from the calcination of limestone, where CaCO<sub>3</sub> is converted to CaO and CO<sub>2</sub>. The remaining emissions are derived from combustion of fuels in the calciner and rotary kiln. A measure such as fuel switch can therefore only remove one-third of the CO<sub>2</sub> emissions, making CC a necessity to become close to CO<sub>2</sub> emission free. The CO<sub>2</sub> contribution from calcination results in higher CO<sub>2</sub> content of cement kiln exhaust gas, which is typically 20-30%-vol. However, depending on whether it is a retrofit project or a new build project, the process configuration will differ substantially.

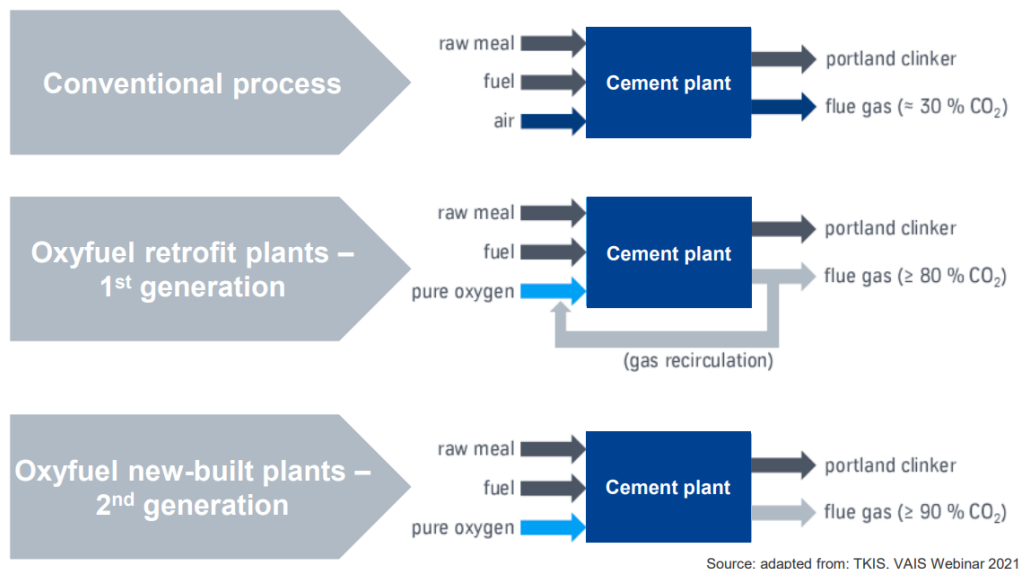

University of Stuttgart - Institute of Combustion and Power Plant Technology - AC2OCem Workshop – 07.03.2023

Figure 18 Schematic representation of conventional, 1 and 2. G oxyfuel cement plants.[2]



In a 1<sup>st</sup> generation oxy-fuel process, combustion is performed with an oxidizer consisting mainly of oxygen mixed with recycled CO<sub>2</sub> rich flue gas to produce a CO<sub>2</sub> rich flue gas, which allows relatively easy purification with a CPU.

Additional power is required for the oxy-fuel process compared to a plant without capture, mainly by an ASU providing oxygen and the CPU. Some of this power demand can be covered by a waste heat recovery system. As an example, an organic Rankine cycle (ORC) can be installed, or surplus heat can be reused for district heating.

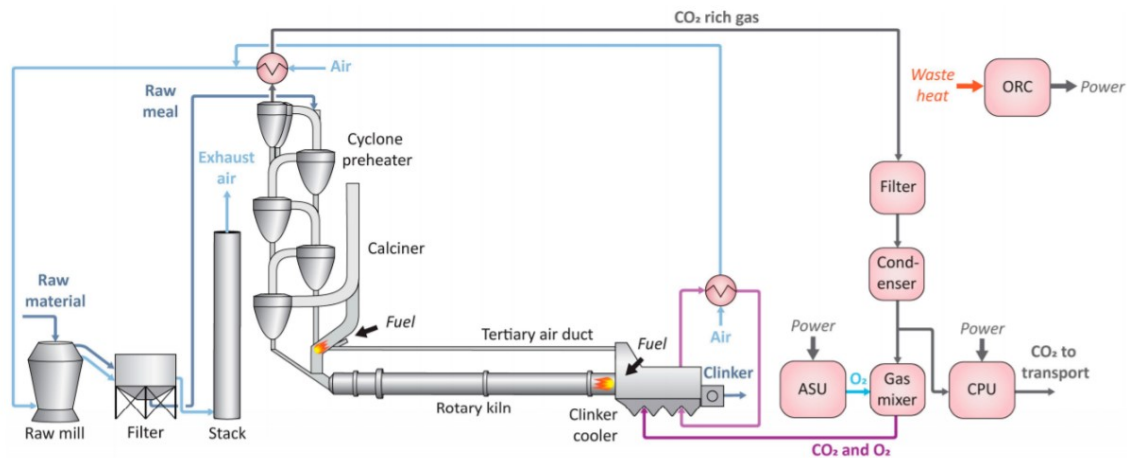

Figure 19 : Cement kiln system converted to oxy-fuel firing. The reddish coloured blocks are new process units.[3, 4]

Conversion to oxy-fuel firing might seem uncomplicated, however the cement process itself must be modified. The gas atmosphere in the clinker cooler, the rotary kiln, the calciner and the preheater is changed, and some of the flue gas is recycled.

Air that is heated by hot gases from the preheater and the clinker cooler is sent to the raw mill to dry the raw material instead of the flue gas. The direct advantage is that the kiln throughput will be increased. Due to the higher CO<sub>2</sub> partial pressure, however, the calciner must operate at an increased temperature (+60°C), which will increase energy consumption, and the choice of construction material shall be re-evaluated. Likewise, fouling when firing alternative fuels may be an issue.

A list of necessary changes can be seen in Figure 20.



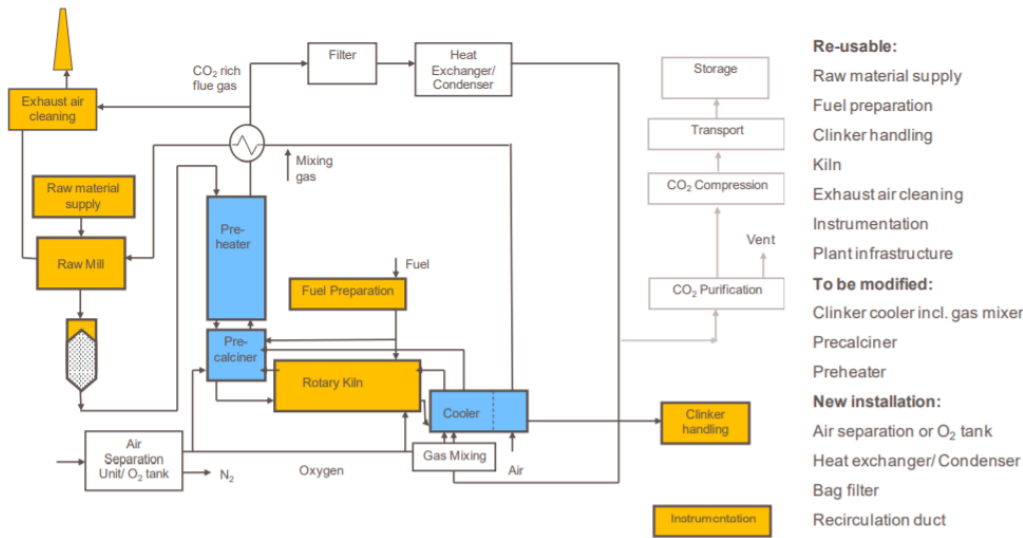

Figure 20 General scheme for an oxy-fuel retrofit concept: White: To be installed new, Blue: To be utilized from existing plant, Yellow: To be modified, Grey: Not needed for proof of concept [5, 6].

A major drawback for the retrofit process is that the outage period for converting a cement plant to oxy-fuel will last 6 months with resulting lost production revenue.

Another main drawback is that even modern cement plants are leaky. A typical flue gas leaving the preheater chain will contain 15% gases that have entered via leaks. The European Cement Research Academy (ECRA) has made an overview of sources of air leakages. This revealed that it may be possible to reduce the proportion of leak ingress to 1% at new plants/totally refurbished plants, but at considerable costs.

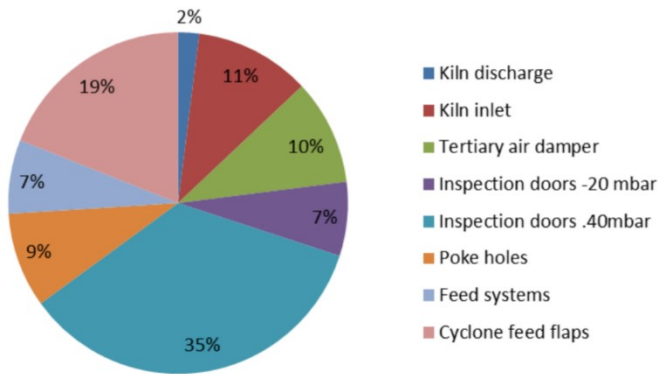

Figure 21 Overview of air-leakages in the preheater and kiln departments at a typical Portland cement plant.[5]

### 1.4 Partial oxy-fuel combustion at cement plants

To reduce the complexity of the oxy-fuel system another option is to perform oxy-fuel combustion on the precalciner since 80% of the CO<sub>2</sub> is generated here.

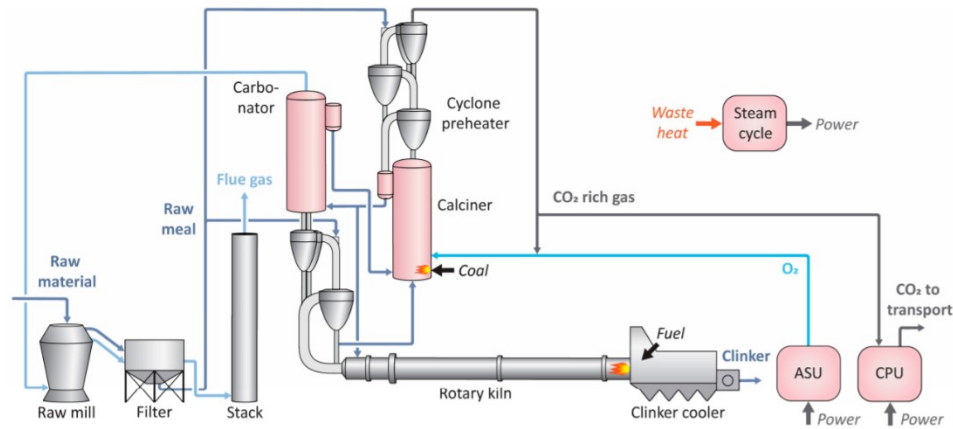
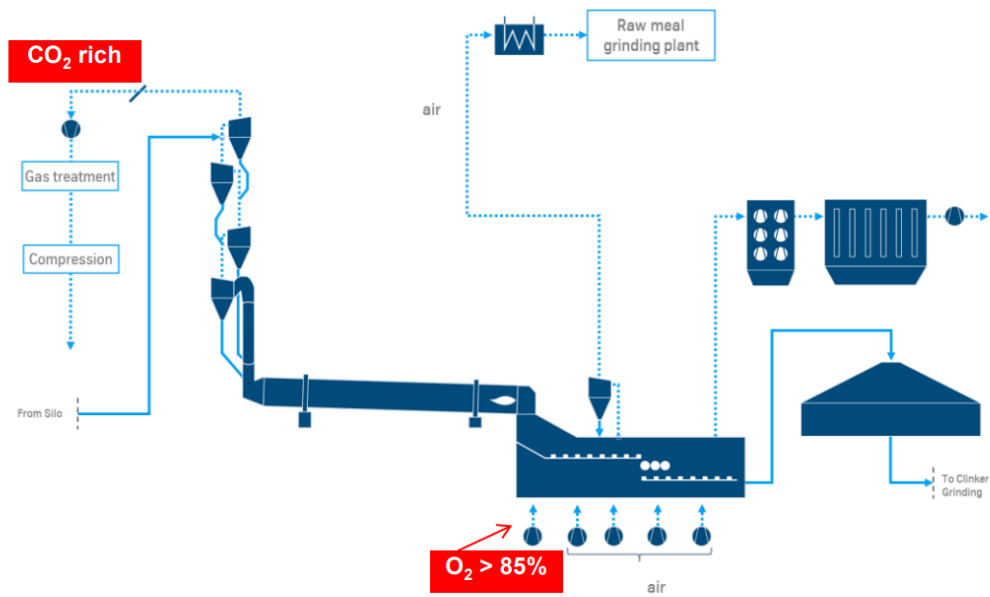

Figure 22. Partial oxy-fuel combustion with integrated Calcium looping.[3]

The benefit of this system is that the kiln and cooler do not require retrofitting, this reduces the cost of installing CC and the size of the ASU can be reduced by 40%. On the other hand, two cyclone preheater towers are required and the utilisation of heat from hot kiln and calciner flue gases will be reduced increasing net fuel consumption. Feasibility studies of the concept has been conducted but no pilot facility has been constructed. A further simplification is to omit the calcium looping part of the process, thereby reducing CO<sub>2</sub> capture to < 80% as the flue gas from the rotary kiln is still emitted. Despite the simplification, ECRA indicates that the cost of CO<sub>2</sub> capture for the partial oxy-fuel case is higher than for the full oxy-fuel case.[3] This is both related to the increased fuel consumption and that the more expensive units (ASU and CPU) are still required.

### 1.5 2<sup>nd</sup> Generation Oxy-fuel combustion at cement plants

The main difference between 1<sup>st</sup> and 2<sup>nd</sup> generation oxy-fuel combustion at cement plants is that recirculation of flue gas will be avoided in the latter. In order to achieve this, major modifications are required for the cooler, burners and cyclones.



Schematic diagram of a 2<sup>nd</sup> generation oxyfuel cement plant without flue gas recirculation circuit

Figure 23: 2<sup>nd</sup> Generation oxyfuel cement plant.[7]

Thus, second generation oxyfuel is only suited for new process lines since retrofitting of existing process lines will require major equipment replacements and upgrade of existing installations.

### 1.6 Hybrid calcination process

To avoid the installation of an ASU, another option is to separate the calcination process from the rest of the combustion processes.



In a conventional cement plant minerals, fuel and combustion air are mixed both in the calcination process and during the clinker burning. The output from the processes are therefore a mixed flue gas and the burned clinker.

The calcination, where approximately 2/3 of the CO<sub>2</sub> are formed, can be conducted by indirect firing.

One example is The LEILAC process (Low Emissions Intensity Lime And Cement) which is based on heating the limestone via a special steel tube – with the heat on the outside of the tube and the limestone or raw cement meal on the inside, thereby producing two separate gas streams - the flue gas and a separate stream of pure CO<sub>2</sub>

Another example is the IHCaI process which also uses indirect calcination but combined with a carbonator where CO<sub>2</sub> from the flue gas is captured by lime (CaO) and later released in the calcinator.

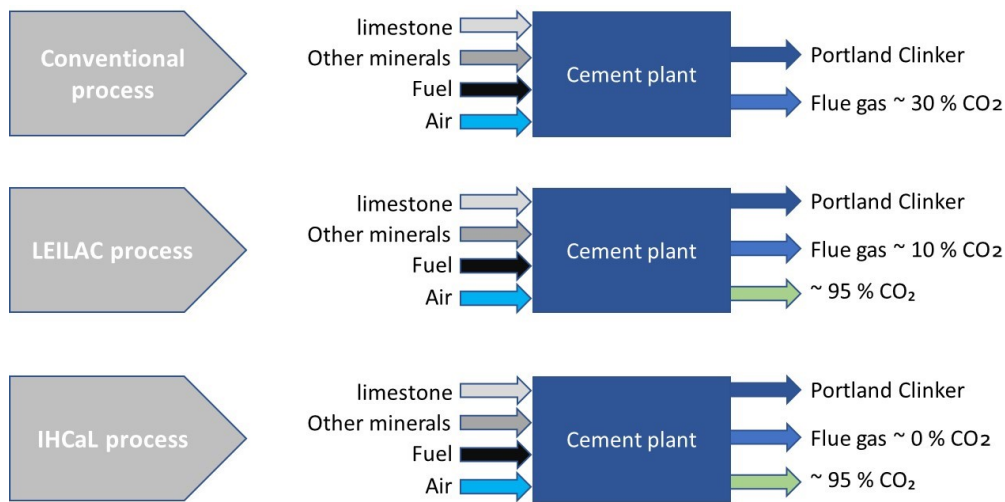

Figure 24 Principal scheme of a conventional, a DSR/LEILAC and an IHCaL cement process.

In the LEILAC process there are two products, a normal flue gas with a CO<sub>2</sub> content around 10% and a nearly pure CO<sub>2</sub> stream (> 95%).

The CO<sub>2</sub> from calcination only needs cooling, drying and compression to be ready for further processing. Whereas the CO<sub>2</sub> from the combustion processes can be removed e.g., using oxyfuel combustion or in a conventional amine scrubber.

If only indirect calcination is used, the CO<sub>2</sub> capture rate will be 60-70% compared to a conventional cement plant.

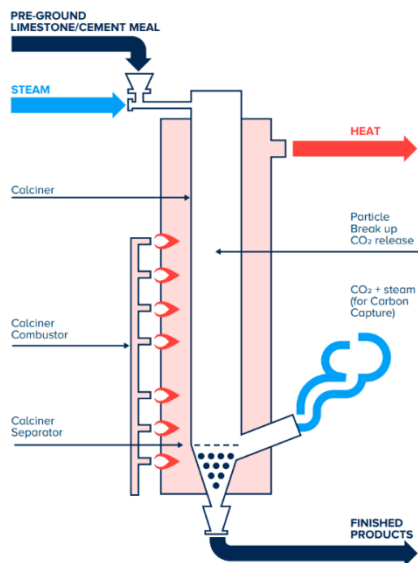
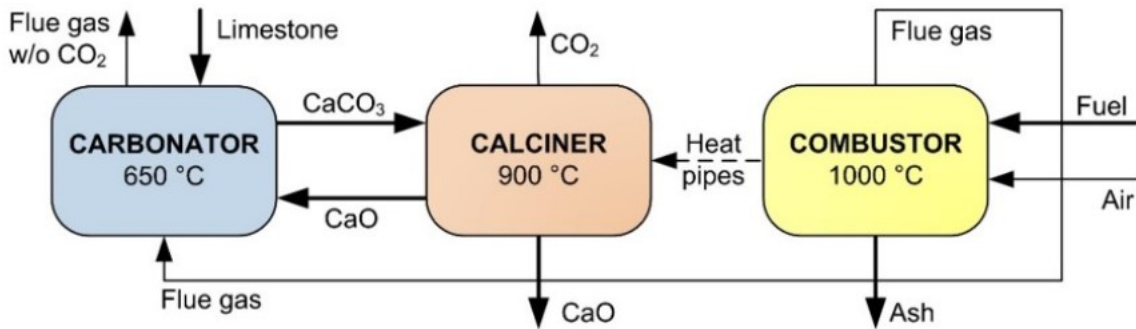

Figure 25 The heart of the process is the indirect fired LEILAC calcinatory.[8]

A more complex indirect calcination process is the IHCaL process (Advanced Indirectly Heated Carbonate Looping Process). In this process the calcinator is combined with a carbonator where CaO reacts with CO<sub>2</sub> to form limestone (A reverse calcination process) The IHCaL is in a more premature development stage as LEILAC, but promises ≥90% CO<sub>2</sub> removal.



**Description of the IHCaI process.[9]**

The LEILAC-1 project involved the construction of a Pilot Plant at the Heidelberg Cement site in Lixhe, Belgium (CBR Lixhe). The Pilot Plant has completed over 1500 hours of test runs. Lixhe cement meal has been processed at up to 8tph and briefly at 10 tph, with an extent of calcination (conversion of limestone to lime) seen at 85%. In all runs, separation of CO<sub>2</sub> was undertaken (>95% purity) directly from the reactor and before any clean up steps.

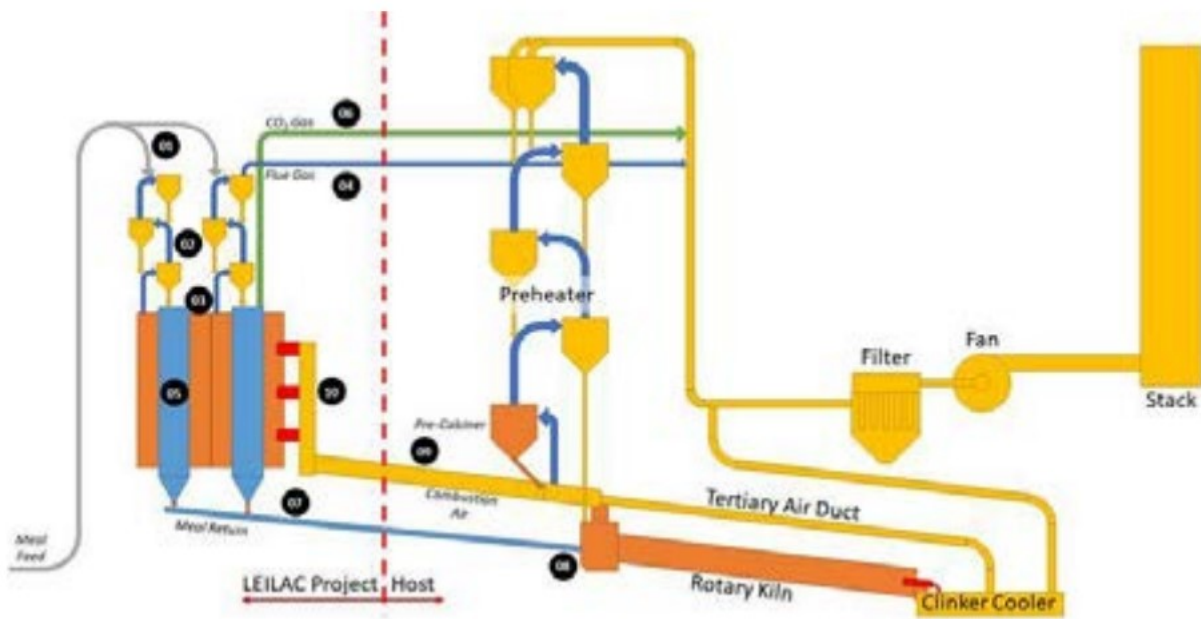

**Figure 26 LEILAC phase 2 – Hannover.[10]**

A follow-on project, Leilac-2, that aims to separate around 100,000 tons of CO<sub>2</sub> per year has been awarded €16m by the EU Horizon 2020 program with additional cash and in-kind industry contributions of €18m. Heidelberg Cement will be the host at their facility in Hannover, Germany.

Current estimates, suggest that indirect calcination may separate CO<sub>2</sub> at a cost of €10/t CO<sub>2</sub> additional OPEX (above the host plant’s operating costs). Total costs of CO<sub>2</sub> avoided of this first-of-a-kind commercial demonstration scale Leilac plant is expected to be in the region of €20-25/t CO<sub>2</sub> plus costs for compression, transport, and storage of the captured CO<sub>2</sub>.

Process simulation showed that the LEILAC project could capture between 58 and 68% of CO<sub>2</sub>, reducing net direct emissions to as low as 0.17–0.21 t CO<sub>2</sub>/t cement. Simultaneously, the impact on thermal duty could be as low as 3.65 GJ/t clinker, representing a nominal increase of ~ 8% compared to the simulated baseline. Somewhat larger electrical duties were required with ~ 30% increase to a calculated value of 154–159 kWh/t cement. However, this increase was almost entirely due to compression of CO<sub>2</sub>, and not due to increased usage by the DSR. Overall, the simulated and costed plants of this research suggested a capture cost of CO<sub>2</sub> between £39-53/tCO<sub>2</sub> for a new build cement plant with DSR technology fueled by natural gas.

### Input

Compared to conventional combustion, the only differences is that pure O<sub>2</sub> is required as input i.e. from ASU or electrolysis unit. The energy penalty for producing pure O<sub>2</sub> by a standard ASU is around 200-220 kWh/ton O<sub>2</sub>.

Instead of installing an ASU unit, it is in principle possible to deliver O<sub>2</sub> from an electrolysis unit producing H<sub>2</sub> and O<sub>2</sub> from e.g. wind power. However, there are technical and commercial challenges in balancing the O<sub>2</sub> production from electrolysis based on volatile renewable energy and the base load operating profile of a cement kiln. Decoupling of O<sub>2</sub> production by electrolysis and the operation of an oxy-fuel cement plant will require storage of large volumes of cryogenic O<sub>2</sub>. An O<sub>2</sub> liquefaction plant + regasifying plant including cryogenic O<sub>2</sub> storage tanks for just few days of operation will be an equal sized investment as an ASU.

### Output

The flue-gas outlet from an oxy-fuel boiler consists primarily of CO<sub>2</sub> and H<sub>2</sub>O. The heat produced by the boiler will be the same as in air firing mode with flue gas condensation (and is not included here as an output).

However, due to air ingress, necessary O<sub>2</sub> surplus, Argon in the O<sub>2</sub>-input stream, nitrogen in the fuel etc. the final dry CO<sub>2</sub> concentration at full load lies between 70 - 90% where only 70% has been demonstrated for retrofit units and 80-90% at new plants. Figure 27-shows the CO<sub>2</sub> concentration reached on dry basis at the oxy-fuel retrofit plant Callide unit 4 as function of unit load. The overall air ingress was within the design limit of 7 % (mass), the maximum achieved CO<sub>2</sub> concentration reached was 71 vol-%, dry at full load, but at 50% load, only 45% CO<sub>2</sub> Vol-%, dry was achieved due to air ingress which is independent of load.

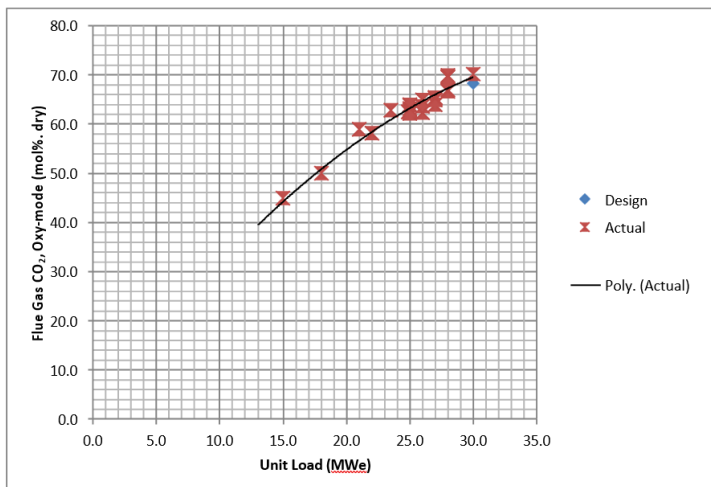

Figure 27 CO<sub>2</sub> concentration dependent on load at Callide oxy-fuel plant from [11]

## Application potential

Technical viable oxy-fuel combustion can be implemented at both power plants and at cement plants if the air ingress can be kept low.

Compared to post combustion amine technology where the resulting CO<sub>2</sub> has a purity above 99%, oxy-fuel CC requires extensive upgrading of the CO<sub>2</sub>. System for upgrading CO<sub>2</sub> is shown in Figure 28

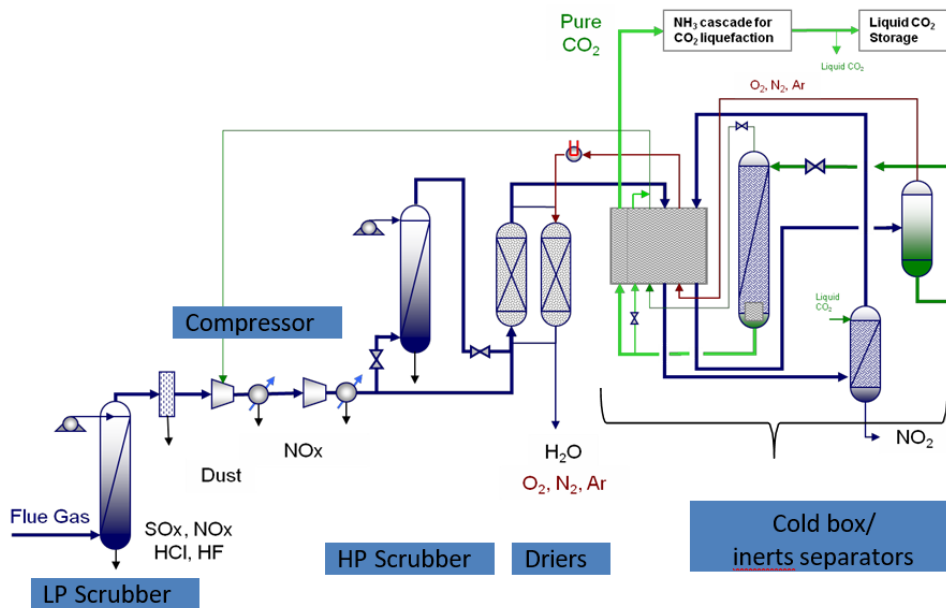

Figure 28 Upgrading of raw CO<sub>2</sub> at Callide oxy-fuel CCS. [11]

Due to the lower purity of the CO<sub>2</sub> it is necessary to remove inerts (O<sub>2</sub>, N<sub>2</sub> etc. by cryogenic distillation. To reduce CAPEX, OPEX and recovery rate for the CPU part of the plant, it is therefore essential to keep CO<sub>2</sub> content above 60-70%. Also, the lower the content of CO<sub>2</sub>, the lower CO<sub>2</sub> capture will be obtained as the venting loss increases in the CPU. The CO<sub>2</sub> purification is further described in section i.13. At lower purities post treatment with an amine scrubber becomes more economical, in which case the oxy-fuel combustion makes no sense.

## Typical capacities

### 1 PC oxy-fuel fired plants

At present no commercial PC fired oxy-fuel plants have been built, but two Demo size projects have been conducted, a retrofit project in Australia and a new built oxy-fuel boiler at Schwarze Pumpe in Germany. As shown in Table 10 oxyfuel has only been demonstrated in relatively small scale e.g. 30-120 MWth.

In Denmark a design study at Studstrupværket has been carried out, but it was concluded that due to the chosen boiler steel, boiler configuration, load change ability etc. it would be more beneficial to build a new power plant.

Table 10. Overview of main PC oxy-fuel fired demonstration projects and the Danish experience (design study).

<b>Unit scale, Location</b>	Demo scale, Retrofit Callide Australia	Demo scale Brown-field Schwarze Pumpe Germany	Full scale retrofit Design study Studstrup Denmark [12]
<b>Unit thermal power</b>	120 MWth	30 MWth	900 MWth
<b>Years of operation</b>	2008-2012	2006-2014	
<b>Aim of research</b>	Process integration Proof of concept	Process integration Proof of concept	Design study Efficiency Proof of concept
<b>Type of fuel</b>	Bituminous coal	Sub bituminous coal	Biomass
<b>Operators</b>	Doable, but project terminated	Too expensive	New plant is preferable
<b>Main conclusion</b>			

## 2 Oxy fuel fired CFB boilers

To date, no commercial-scale (>300 MW<sub>th</sub>) oxy-fuel CFB boiler has been built despite the technology currently having a TRL of 7–8 [13], however several experimental Oxy CFB units have been built and operated as shown in the table below:

Table 11 Oxy-fuel CFB experimental units.

<b>Unit scale, Location</b>	Industrial-scale, CIUDEN, Spain	Industrial-scale, Valmet, Finland	Pilot-scale, CanmetENERGY, Canada	Pilot-scale, University of Utah, USA	Pilot-scale, University of Stuttgart, Germany
<b>Unit thermal power</b>	30 MWth	4 MWth	0.8 MWth	0.33 MWth	0.15 MWth
<b>Years of operation</b>	2011–2014	2013–present	2011–2017	2011– present	2014– present
<b>Aim of research</b>	sulphur capture potential	combustion, heat transfer safety	combustion and pollutant formation	SO <sub>3</sub> formation under oxy-fuel conditions	Solid burnout and emission of CO and NO <sub>x</sub>
<b>Type of fuel</b>	petcoke, coal and biomass	Bituminous coal	Coal, petcoke and lignite	bituminous coal	Bituminous coal

## 3 Cement plants

No integrated oxy-fuel cement plants have been erected at any scale. Some of the single unit operations have been proven in lab scale.

### Space requirements

Limited additional space is required for the modifications at the energy plant or cement kiln. However, the ASU and CPU require relatively extensive area.

- CPU: 15 m<sup>2</sup>/[t CO<sub>2</sub> output/h]
- ASU: 30 m<sup>2</sup>/[t CO<sub>2</sub> output/h] for biomass plant and 10 m<sup>2</sup>/[t CO<sub>2</sub> output/h] for cement kiln



### Regulation ability

The main challenges with operation of oxy-fuel combustion systems are:

- Air leakages
- Start-up time for the ASU from ambient temperature
- Load ranges and load changes
- Complexity of operation of ASU, combustion and CPU as one integrated unit

The start-up time for the cryogenic ASU dictates the start-up for the complete plant in CC mode. The start-up time for a cryogenic ASU after long shut-down is around 60-70 hours, but if the stop is less than 24 hours it can be reduced to 2-3 hours due to a very efficient insulation of the cold box. The minimum load range for the ASU is around 30%,

The robustness of operation of the complete oxy-fuel combustion and CPU depends on how intimate the heat integration is and on whether adequate buffer storages have been applied. However, optimised heat-integration will reduce the load change ability. Because of the volatile power production from wind and solar plants, thermal power plants operating in the same market are typically required to balance production. It will be challenging to operate oxy-fuel power plants under such fluctuating conditions.

On the contrary, a Portland cement plant normally operates at full capacity with only minor fluctuations, hence an oxy-fuel cement plant will be easier to operate.

At power plants, the purity of CO<sub>2</sub> in the flue gas diminishes at low load. As a rule of thumb, the purity of the CO<sub>2</sub> should be > 60-70% to operate a CPU unit based on standard compression and dehydration, if the purity gets lower it is necessary to go through another purification step such as amine scrubbing, in which case oxy-fuel combustion makes no sense. At Cement plants air leakages are significant at all loads, requiring refurbishment before oxy-fuel combustion is a realistic option.

Basically, CFB boilers are more suitable for oxy-fuel retrofitting than grate and PC boilers as CFB boilers in principle are airtight, however, fans, ash outlets etc. are not completely airtight even if CO<sub>2</sub> is used as sealing air.

For a retrofit boiler, depending on design, it will probably be possible to reach 70-75% CO<sub>2</sub> at full load, but only 50-60% at half load, however an individual design study is needed for each unit to verify the achievable performance.

### Advantages/disadvantages

#### 1 PC and CFB fired boilers

The primary advantage with the retrofit oxy-fuel process is the potential saving on investment cost compared to post combustion capture as the existing boiler can be modified to oxy-combustion.

Nevertheless, both the air separation unit (ASU) for O<sub>2</sub> generation and the CO<sub>2</sub> purification unit (CPU) are expensive and energy intensive units, hence the cost saving potential will be rather limited. However, access to alternative O<sub>2</sub> source e.g. surplus production from electrolysis, will increase the attractiveness of oxy-fuel conversion.

Many of the advantages with the oxy-fuel process that can be achieved with newbuilt oxy-fuel boilers will however disappear with retrofitted boilers. This particularly concerns the issue with excessive air ingress which results in increased CAPEX and OPEX to the CPU. The percentages of air-ingress depend on boiler type in the following order: Grate fired > PC-fired > CFB. CFB boilers therefore have the best potential. However, no references on retrofitting CFB boilers exists and load following on the very volatile electricity market will be a big challenge for the complex integrated system.

### 2 Cement plants

As both the CAPEX and OPEX for the ASU or alternative oxygen generation are high, the mass of recovered CO<sub>2</sub> per ton O<sub>2</sub> produced should be as high as possible. This favours the (partial) oxy-fuel combustion applied at cement plants, as 3-4 times as much CO<sub>2</sub> is captured per unit O<sub>2</sub> consumed compared to that of energy plants. This is due to the calcination process  $\text{CaCO}_3 \rightarrow \text{CaO} + \text{CO}_2$  which releases additional CO<sub>2</sub> without consumption of O<sub>2</sub>. Another advantage is that cement plants are operated continuously at full load, hence reducing issues with long start-up times of oxy-fuel process and ASU.

A disadvantage is the rather comprehensive modifications required to the cement plant for oxyfuel retrofit (both full and partial conversion), which will require long downtime for the facility.

A promising option is however to accept a lower capture rate and retrofit the calciner to indirect firing. As this does not involve changes to the cement kiln nor installation of a costly ASU, cost calculations based on pilot tests suggests a CAC (Cost of Avoided CO<sub>2</sub>) exclusive compression around 25€/tons

### Environmental

In oxy-fuel combustion no new chemicals are introduced but handling of O<sub>2</sub> requires ATEX zones (from the French: ATmospheres EXplosives) and ATEX equipment, as most organic material ignites spontaneously in pure O<sub>2</sub>.

Concerning the flue gas, the high content of CO<sub>2</sub> is a risk factor too, as the density of CO<sub>2</sub> is 60% higher than dry air, CO<sub>2</sub> could be concentrated in basements and other low lying pockets in the plant building.

### Research and development perspectives

At PC fired boilers no major R&D projects are ongoing as the potential is regarded as limited.

At Oxy-CFB the main driver for future plants is the option to reduce the size of the boiler by up to 80% by increasing the oxygen concentration (in the bottom) of the CFB from 21% to 50-80% Figure 29. This requires however, increasing the mass of circulating fluid bed material (sand used for heat transfer etc.) considerably to keep the bed temperature down. I.e., instead of recirculation of flue gas, a larger amount of bed material is recirculated. This applies however only for new build plants.

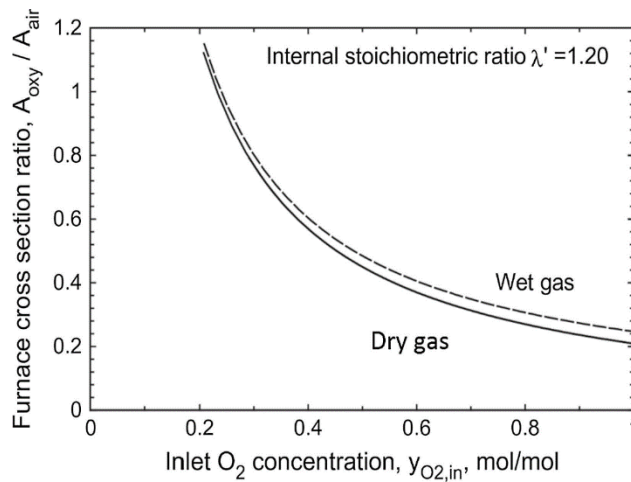

Figure 29 Potential to reduce boiler size by increasing O<sub>2</sub> concentration.[14]

With reduced boiler size the capital cost for the boiler is reduced considerably, which might totally offset the cost of the ASU unit making new Oxy-CFB viable.

These 2<sup>nd</sup> generation oxy CFB's are still at a very early stage, demonstration units have not been built and commercial plants will not be erected within the next decade.

For retrofit Oxy-CFB, increasing O<sub>2</sub> to 50-80% is not an option, as the furnace size is fixed. The cost of retrofitting a CFB boiler to oxy fuel combustion is therefore more or less comparable to retrofitting a PC boiler. As the three major changes, the ASU, the CPU and the flue gas recirculation are in principle the same. As no development work is ongoing, it is very unlikely that a viable retrofit system will be ready within the remaining lifetime of existing CFB boilers.

## Examples of market standard technology

At present standard market technology does not exist, but several demonstration plants have been built.

### 1 Retrofit of Callide a unit 4

In reality, retrofit of a power plant is more complicated than illustrated in the introduction. As an example, the retrofit of the power plant Callide A, unit 4 is described in the following.

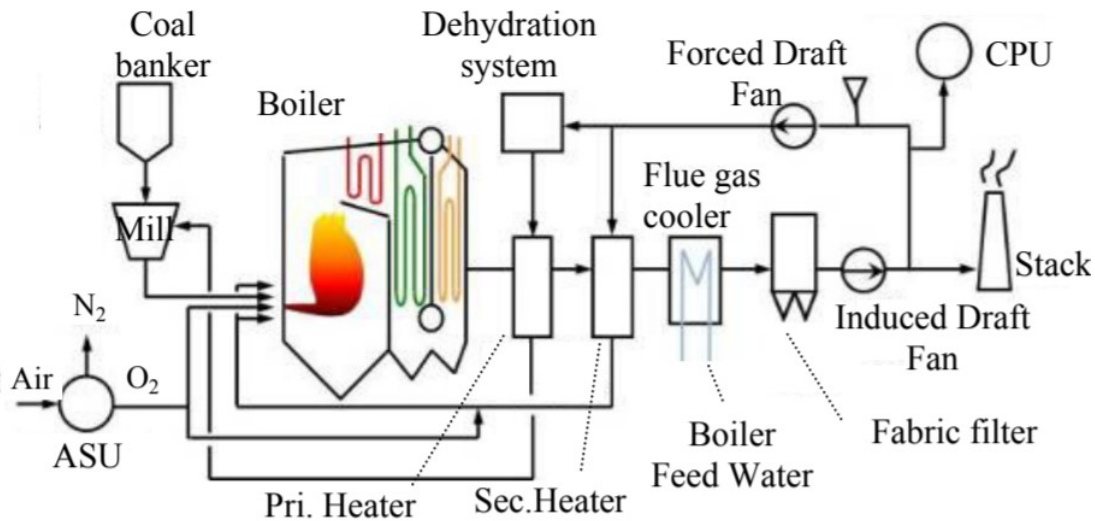

Figure 30 Illustration of the rebuilds needed to retrofit Callide A unit 4.[11]

The first step was operation of the boiler in air-fired mode for several months to ensure that the total plant (especially turbine, boiler, and SCADA system) had a residual life of at least 5 years, based on this, the retrofit was designed. Major new equipment included:

- Installation of two x 330 t/day air separation units (ASUs)
- Installation of a 75 t / day CO<sub>2</sub> purification plant (CPU) for the treatment of a side stream (~10%) of flue gas from the Oxy-fuel boiler.

Simultaneously, the retrofit of the boiler system was carried out over a period of 2 years. New boiler components included:

- Replacing the middle burner row with Low NO<sub>x</sub> burners with two O<sub>2</sub> injection lances per burner
- New flue gas low pressure preheater
- New induced draft fan
- Gas recirculation fan
- Flue gas condensation (dehydration system)

Above are listed the rebuilds that were needed to complete the trial program. If it had been a commercial plant, the plant owners would have considered further improvements which included:

- Improved integration of the ASUs with the oxy-fuel boiler by establishing buffer storage for cryogenic O<sub>2</sub>
- Further development of the SCADA concept, including improved transition from air to oxy mode, as well as interaction between ASU, oxy-fuel boiler and CO<sub>2</sub> purification.

- Finally, an improved process and heat integration between ASU, Oxy-fuel boiler and CO<sub>2</sub> purification must be made and the unit operations: ASU, Oxy-fuel boiler and CO<sub>2</sub> purification must each be optimized.



Figure 31 Photo of Callide Oxy-fuel boiler from [11] showing retrofit paths (red) and flue gas flow directions (yellow).

## 2 Oxy-CFB experimental units

The best documented Oxy-CFB boiler is Ciuden's 30 MWth experimental plant at Central térmica Compostilla II in north-western Spain.

The demonstration unit was established around 2008 and was in operation until 2014. The plant was equipped with flue-gas purification and compression of CO<sub>2</sub>. The focus was to prepare for a 330 MWe coal-fired ultra-supercritical Oxy-CFB plant at the nearby power plant.

The test plant was a Foster Wheeler Flexi-Burn® concept that enabled either conventional or oxy combustion operation. Interestingly, the maximum boiler capacity for air combustion was 15 MWth, while the capacity under oxy-fuel conditions was 30 MWth.

The reason for the substantially increased capacity is the high heat capacity in the solid bed material, which allows for additional firing. The fluid bed temperature either can be reduced by flue gas recirculation or alternatively by increased recirculation of bed material.

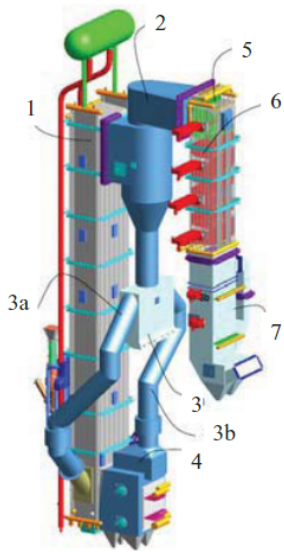

- (1) combustion chamber
- (2) solid separator
- (3) ash sealing-direction device
- (3a) ash duct to the furnace
- (3b) ash duct to the cooler
- (4) furnace cooler - INTREX™
- (5) heat recovery zone
- (6) steam cooled walls
- (7) economizer

<b>Furnace dimensions (m)</b>	<b>20x2.8x1.65</b>
Thermal power (MW <sub>th</sub> )	15 (air mode) 30 (oxy mode)
Max steam flow (t/h)	47.5
Superheated steam T (°C)	250
Superheated steam p (bar)	30
Feed water T(°C)	170
Outlet flue gases T (°C)	350-425

Figure 32 Ciuden's 30 MWth experimental plant at Central térmica Compostilla II in northwestern Spain [15].

It was anticipated that a full-scale Oxy-CFB plant should be operational in 2015, however the Ciuden project group have instead focused on further cost reduction to make the project viable. The focus in a newer EU project "Optimization of oxygen-based CFBC technology with CO<sub>2</sub> capture" have been:

1. Reduction of ASU energy consumption to 150 kWh/ton O<sub>2</sub>
2. Reduction of Capex by increasing O<sub>2</sub> to 40-50% in the CFB
3. Improved integration of ASU, CFB and CPU

Except for the ASU, these improvements are only relevant for new plants due to the major increase in thermal output if a retrofit is carried out requiring a new turbine and new heat exchangers, and it would also be challenging to implement on a biomass fired unit due to lower ash melting points.

At Ciuden transition from air to oxy mode could be automated and carried out within 30-40 minutes in both directions. The unit was able to achieve 80 vol-% CO<sub>2</sub> dry, corresponding to 3% air ingress, however a higher CO<sub>2</sub> content is necessary to reduce the CAPEX and OPEX for the CPU.



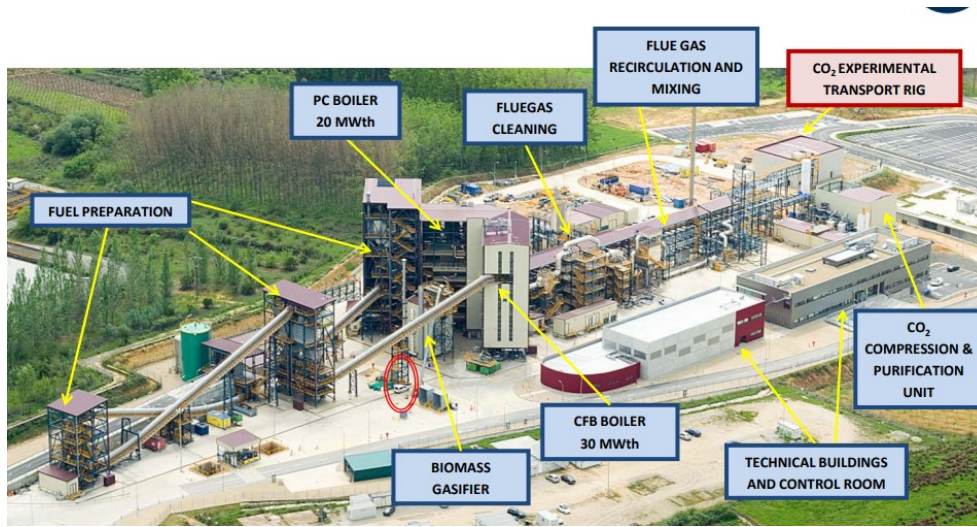

Figure 33 Ciuden's Demonstration site. [16]

## Prediction of performance and cost

### 1 PC and CFB fired units

Retrofit of power plants to oxy-fuel combustion will never be a standard product. Due to the integration with the existing process, individual design studies for each project are needed covering:

- Options to minimize air ingress
- Recalculation of the energy transfer in the boiler and design of new heat-exchangers, O<sub>2</sub> and flue gas mixers, flue gas dehydrators, flue gas recirculation ducts, new fans and blowers etc.
- Based on the above the CPU can be designed

The only completed retrofit conversion of a power plant to oxy fuel firing was the Callide PC power plant and economic data are extrapolation from the number given in the public report. Although the retrofit costs will not be one to one comparable to CFB units, retrofit of either PC or CFB involves many of the same modifications and new installations, hence the cost estimate may be applied as a first estimate for both cases.

The Callide Oxy-fuel Project Capital Costs are summarised below. These data include an escalation to 2017 AUD assuming a CPI of 1.5% per year.

Table 12 Summary of Callide Oxy-fuel Capital Costs (rounded) [11].

CAPEX	Boiler – Air-firing refurbishment	Boiler – Oxy-fuel retrofit (120 MW <sub>th</sub> )
2017 mill AUD	10	50.8

The capacity of Callide A from 1965 was 120 MW<sub>th</sub> (30MW<sub>e</sub>), with dry cooling towers etc. this corresponds to a thermal capacity of around 25% of the size of e.g. BIO4 at Amager.

A cost extrapolation for large scale plant was in the project estimated using the “Rule of Six Tenths”. ([size<sub>1</sub>/size<sub>2</sub>]<sup>0.6</sup>). For a 500 MW<sub>th</sub> unit it gives a cost factor of 2.35

At present with the huge uncertainties given, it is anticipated that cost for retrofitting a PC and a CFB boiler are at the same level.

Below is presented the extrapolated costs for a 500 MW<sub>th</sub> boiler oxy-fuel conversion (excluding CPU and ASU), currency conversion rate 0.67€/AUD, primo 2017, 1,5% CPI.

**Table 13 Extrapolated costs for a 500 MW<sub>th</sub> boiler oxy-fuel conversion in Euro (rounded) [11].**

CAPEX, 2020	Refurbishment	Oxy fuel retrofit (boiler)
<b>Total costs 500 MW<sub>th</sub></b>	16 mill. €	83 mill €
<b>Specific investment (mill € /[t CO<sub>2</sub> output/hour])</b>	0.1 mill. €	0.47 mill. €

The uncertainty on the numbers above are quite substantial. The cost of the oxy-fuel retrofit depends on the boiler design.

## 2 Cement plants

Oxy-fuel retrofit to an existing cement kiln will require substantial modifications to the kiln system, clinker cooler and entire flue gas path. As it will impact the gas flow through the preheating tower and downstream process, the heat balance will also be affected. In addition, ASU and CPU units are required. As there is no standardized solution to retrofit cement plants and deployment of the solution is expected to be low, the learning rate will be limited and no large cost reductions can be expected until 2050.

In the SINTEF coordinated EU project AC<sup>2</sup>OCEM two cement plants have been investigated for retrofit.

Lägerdorf cementplant in Schleswig-Holstein, a 4400 tonne Clinker pr day operating on 20% moist raw material and the Heidelberg cement plant Slite on Gotland in Sweden, a 5600 ton clinker per day plant operating on 2-3% moist raw material.

The main result was that the cost of CO<sub>2</sub> avoided increased considerably compared to earlier studies such as ECRA and CEMCAP. The main explanation to the cost increase is that the former studies were conducted on generic plants. At real plants, there are space constraints, and process modifications turned out to be more complex, and the contingency estimation were different.

Other results from the AC<sup>2</sup>OCEM project are that CAC is markedly dependent on both the electricity price and the CO<sub>2</sub> intensity on the consumed electricity.





## Comparison with previous studies

Estimate	Cost year	CAC [€/tonne CO <sub>2</sub> ]
AC2OCem Slite	2019	67
AC2OCem Lägerdorf	2019	83
CEMCAP	2014	42
ECRA	2009	45

- Higher CAPEX
  - Real plants considered instead of hypothetical reference plant
  - Increased understanding on complexity of modifying existing plants (core process CAPEX)
  - Higher CPU CAPEX based on estimate by technology supplier
  - Extended scope: pipelines and CO<sub>2</sub> buffer tanks are included
- Plant downtime included
- Higher O<sub>2</sub> consumption in real plants compared to reference plant
- Slightly different evaluation frameworks in the three studies (e.g. contingency estimation)
- Other differences: Location factors, cost years, electricity cost and CO<sub>2</sub> footprint

**A combination of several factors gives significantly higher CAC than in previous studies**

Note: Due to differences in assumptions, scope, and evaluation framework, costs of other technologies evaluated in CEMCAP cannot be directly compared with AC2OCem oxyfuel costs.

Disclaimer: All estimates presented in this presentation are based on literature data, publicly available data, and assumptions. Plant specific data have not been used in the calculations.

Figure 34 Main results regarding CAC in €/tonne CO<sub>2</sub> (2019) [ 17,18]



## Cost of avoided CO<sub>2</sub> (CAC)

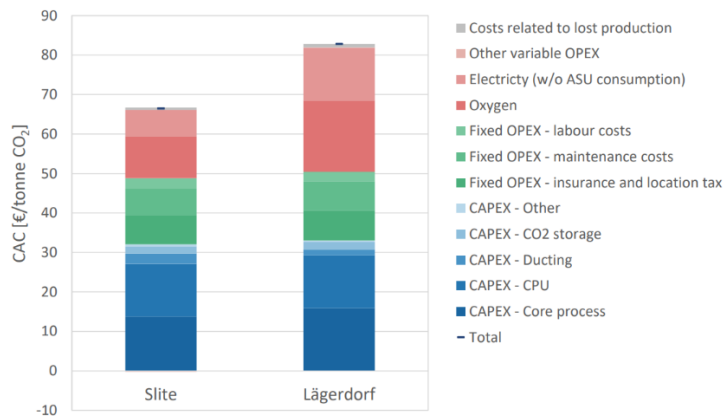

- Direct and indirect emissions are considered
- Lägerdorf higher CO<sub>2</sub> avoided than Slite due to a different process

Figure 35 Cost of avoided CO<sub>2</sub> at Slite and Lägerdorf Cement plants

In the project sensitivity analysis were carried out, the main result were that CAPEX and electricity price had the greatest impact on CAC.

**CAC sensitivity to electricity price and CO<sub>2</sub> intensity**  
(includes impact of electricity price on oxygen cost)

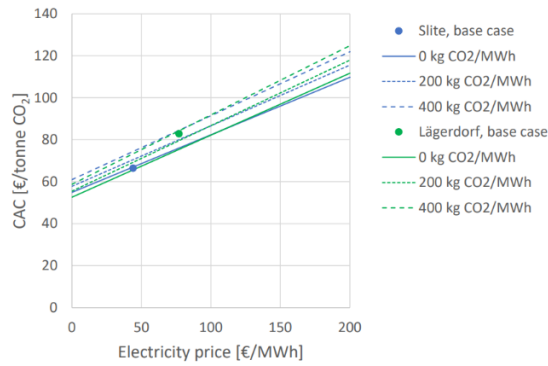

**CAC sensitivity to CAPEX**

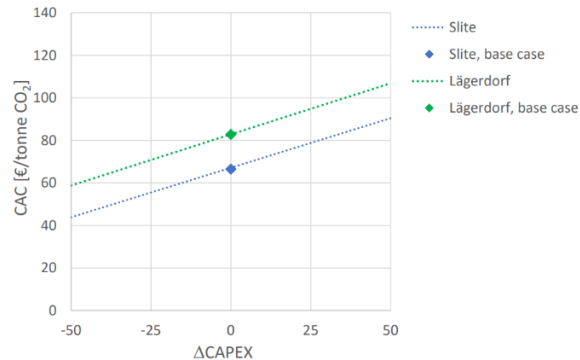

Disclaimer: All estimates presented in this presentation are based on literature data, publicly available data, and assumptions. Plant specific data have not been used in the calculations.

**Figure 36 CAC sensitivity to electricity price, CO<sub>2</sub> intensity and CAPEX**

### 3 CO<sub>2</sub> purification oxy-fuel plant (CPU)

The oxy-fuel process will recover CO<sub>2</sub> at relatively low purity due to the presence of nitrogen and oxygen. The industrial method for purifying the CO<sub>2</sub> is through liquefaction and stripping (distillation) of liquid CO<sub>2</sub> to remove non-condensable gases (O<sub>2</sub>, N<sub>2</sub>, Ar). This is in principle a similar approach as described under CO<sub>2</sub> liquefaction. If the CO<sub>2</sub> has low purity from the oxy-fuel plant say below 80-85% it may be difficult to liquefy CO<sub>2</sub> in a standard liquefaction process (requires higher pressure and lower temperature). This will increase cost as more advanced chiller or compression process is used. In addition, flue gas pollutants such as NO<sub>x</sub> and SO<sub>2</sub> carried with the CO<sub>2</sub> from the oxy combustion may require further purification steps such as activated carbon filtration, NO<sub>x</sub> Trap and water wash, etc. This will also create minor waste streams depending on the contents of acid contaminants in the flue gas reaching the CPU.

The high share of non-condensable gases (15-20 %-vol) will increase CO<sub>2</sub> liquefaction costs and will imply purging loss or recycle of some of the captured and liquefied CO<sub>2</sub>.

The CAPEX estimate for CPU is uncertain as no large-scale units have been built. However, one can assume it will be significantly more expensive than a standard CO<sub>2</sub> liquefaction unit which receives >99% pure CO<sub>2</sub> as input. In the Callide oxy-fuel project a CPU with 3.1 t CO<sub>2</sub> output/h was reported to 31.7 mill AUD [11], which corresponds to 6.8 mill EUR/(t CO<sub>2</sub> output/h). In the ECRA cement retrofit study [19] **Fejl! Henvisningskilde ikke fundet.** a 94.5 t CO<sub>2</sub> output/h CPU was reported to 0.7 mill EUR/(t CO<sub>2</sub> output/h). Savings due to scale cannot explain the entire cost gap, hence the ECRA estimate seems too optimistic.

Table 14. CO<sub>2</sub> purification (99.9%) and liquefaction/compression (to ~150 bar) after an oxy-fuel process.

	Estimated value	Comment
<b>Purification electricity use</b>	~0.16-0.2 MWh <sub>e</sub> /ton CO <sub>2</sub>	Includes chillers, CO <sub>2</sub> dehydration and compression. depending on CO <sub>2</sub> purity
<b>CO<sub>2</sub> capture</b>	90-95%	Some CO <sub>2</sub> is vented in the purification process
<b>Cooling requirement</b>	~0.3 MWh/ton CO <sub>2</sub>	~50% of cooling is through chiller air cooler
<b>CAPEX CO<sub>2</sub> liquefaction/purification</b>	0.7 – 1.8 mill €/ (t CO <sub>2</sub> /h)	Depending on capacity and CO <sub>2</sub> purity. This is uncertain no large-sale units have been built

#### 4 Air separation unit (ASU)

The air separation unit is a very significant part of the cost of an oxy-fuel installation. The CAPEX of large-scale standard ASU plants per unit O<sub>2</sub> produced is given in Table 15. This is converted to cost per t CO<sub>2</sub> output/captured for both a biomass-fired unit and a cement plant. The O<sub>2</sub> cost is lower per unit of CO<sub>2</sub> for cement kiln due to the CO<sub>2</sub> released from calcination as explained in section 2.

Table 15. Estimated CAPEX of large-scale Air Separation Unit (100-250 t O<sub>2</sub>/h). The cost per unit CO<sub>2</sub> output is higher for biomass than cement because more CO<sub>2</sub> is released per unit O<sub>2</sub> in a cement plant as explained in section Advantages/disadvantages about Cement plants.

	CAPEX	Comment
<b>ASU CAPEX</b>	0.9 mill EUR/(t O <sub>2</sub> /h)	Based on ref. [20]
<b>Cost per unit CO<sub>2</sub> capture for biomass CHP</b>	0.8 mill EUR/(t CO <sub>2</sub> output/h)	Assuming 96% CO <sub>2</sub> is captured
<b>Cost per unit CO<sub>2</sub> capture for cement</b>	0.3 mill EUR/(t CO <sub>2</sub> output/h)	Assuming 96% CO <sub>2</sub> is captured

#### Quantitative description

For oxy-fuel combustion the following two data sheets have been prepared:

- Oxy-fuel CC – Retrofit 500 MW biomass boiler
- Oxy-fuel CC – Retrofit 3,000 t clinker per day cement kiln

The data sheets are shown in separate Excel file.

## References

- [1] NREL. <https://netl.doe.gov/node/7477>. [Accessed 10<sup>th</sup> July 2023].
- [2] C. A. M. J. Kroumian, Advanced oxyfuel burner technologies, i *AC2OCem and ANICA Workshop*, Düsseldorf, 2023.
- [3] J. Ahn, R. Okerlund, A. Fry, E.G. Eddings. Sulfur trioxide formation during oxy-coal combustion. *Int J Greenhouse Gas Control*, 5 (Supplement 1) (2011), pp. S127-S135
- [4] M. Voldslund, CEMCAP techno-economic and retrofitability analysis, *ECRA/CEMCAP/CLEANER Workshop, 17.10.2018*, Brussels, 2018.
- [5] Tan, L. Jia, Y. Wu, E. Anthony. Experiences and results on a 0.8 MWth oxy-fuel operation pilot-scale circulating fluidized bed. *Appl Energy*, 92 (2012), pp. 343-347
- [6] J. R. Volker Hoenig, sintef.no, 2018. [Online]. Available: [https://www.sintef.no/globalassets/project/cemcap/presentationer/17-oct-2018/8\\_perspective\\_on\\_oxyfuel\\_capture-technology-application-in-a-cement-plant\\_v.hoenig\\_j.rupert.pdf](https://www.sintef.no/globalassets/project/cemcap/presentationer/17-oct-2018/8_perspective_on_oxyfuel_capture-technology-application-in-a-cement-plant_v.hoenig_j.rupert.pdf). [Accessed 10<sup>th</sup> July 2023].
- [7] J. Mayer, »Accelerating Carbon Technology in Cement Production- AC<sup>2</sup>OCem Capture using Oxyfuel,« i *AC2CEM*, Athen, 2019.
- [8] D. Rennie, »Capturing CO<sub>2</sub> in Cement Precalciners,« Leilac, 2021.
- [9] Anica, »anica,« [Online]. Available: <https://act-anica.eu/the-ihcal-process/>. [Accessed 10<sup>th</sup> July 2023].
- [10] leilac.com,« [Online]. Available: <https://www.leilac.com/report/leilac2-pre-feed-report/>. [Accessed 10<sup>th</sup> July 2023].
- [11] Chris Spero, Toshihiko Yamada. Callide Oxyfuel Project, Final Results, March 2018. <https://www.globalccsinstitute.com/archive/hub/publications/202090/cop-finalresults-publicreport-march2018.pdf>
- [12] Toftegaard, M.B et al. – PSO 7171 – Oxyfuel Combustion for below zero CO<sub>2</sub> emission, DTU Chemical Engineering, 2011
- [13] Teknologisk Institut, 2015.
- [14] Sadegh Seddighi et al. Scale-up challenges and opportunities for carbon capture by oxy-fuel circulating fluidized beds; *Applied Energy*, Volume 232, 15 December 2018, Pages 527-542
- [15] M. Lupion, I. Alvarez, P. Otero, R. Kuivalainen, J. Lantto, A. Hotta, et al. 30 MWth CIUDEN Oxy-cfb boiler - first experiences. *Energy Procedia*, 37 (2013), pp. 6179-6188
- [16] Lupion, I. Alvarez, P. Otero, R. Kuivalainen, J. Lantto, A. Hotta, et al. 30 MWth CIUDEN Oxy-cfb boiler - first experiences. *Energy Procedia*, 37 (2013), pp. 6179-6188
- [17] Techno-economic Evaluation of Oxyfuel CO<sub>2</sub> Capture in European Cement Plants; <https://app.cristin.no/results/show.jsf?id=2140803>
- [18] Mari Voldsund et al. Comparison of Technologies for CO<sub>2</sub> Capture from Cement Production—Part 1: Technical Evaluation; *Energies* 2019, 12(3), 559
- [19] ECRA CCS Project – Report on Phase III. European Cement Research Academy. Technical Report TR-ECRA-119/2012.
- [20] S. Alavandi, J. Seaba, G. Subbaraman. Emerging and Existing Oxygen Production Technology Scan and Evaluation. Gas Technology Institute project no. 22164. Final Report, April 24, 2018.

## 403 Direct Air Capture (DAC)

### Contact information

- Contact information: Danish Energy Agency: Emil Esketveit Rasmussen emrm@ens.dk; Christoph Wolter chwo@ens.dk.
- Author: Albert Pujol Duran from COWI, apdu@cowi.com.

### Brief technology description

Direct Air Capture (DAC) technologies harvest CO<sub>2</sub> directly from the air and are a key technology in the carbon removal portfolio and the overall climate change mitigation strategy. DAC holds the potential to decarbonize the atmosphere, and for providing a CO<sub>2</sub>-feedstock for functional industrial applications, i.e., e-fuels production. Continued demand for cement, steel and fuels (major contributors to CO<sub>2</sub> and GHG emissions) are driving the movement for DAC systems implementation, and momentum in this technology field is gaining rapidly. Nevertheless, current DAC systems are energy, resource, and cost intensive; the CO<sub>2</sub> concentration in the atmosphere (0.04 volume percent) is low relative to conventional point source capture from flue gases (10–25 volume percent). The large amounts of processed air result in high fan power, large equipment capture area and steep energy requirements to desorb the captured CO<sub>2</sub> from the sorbent.

### DAC established concepts

The two most mature and hence most relevant types of DAC technologies for near to mid-term deployment are:

- Solid adsorption and low temperature regeneration.
- Liquid absorption and high temperature regeneration.

The solid adsorption process (S-DAC) operates by sucking air from the atmosphere and directing the flow through a solid activated filter material that chemically binds with the CO<sub>2</sub>. The Swiss company Climeworks is the main commercial leader, currently. The filter is typically made of a polymeric material with amine functional groups. Once the filter reaches saturation (sorbent loading times range from 4.5 to 320 minutes), the desorption process is activated by applying heat and reducing pressure. The filter is typically heated to 85-100 °C with a low temperature heat source, which could be supplied by electricity or other sources such as waste heat from industrial processes, geothermal energy or solar thermal energy. Solid sorbent systems estimate energy requirements of around 7.2 GJ per captured ton. CO<sub>2</sub> is released in a concentrated stream with purities of 98-99.9%. Depending on the adsorbent, moisture can also be adsorbed from air, being released during regeneration of the filter. Baseline designs (Figure 37) tend to desorb CO<sub>2</sub> and water simultaneously and then separate them downstream by condensation. Hence, a stream of process water is co-produced. After regeneration the filter is cooled to ambient temperature, and it is ready for a new cycle [1].

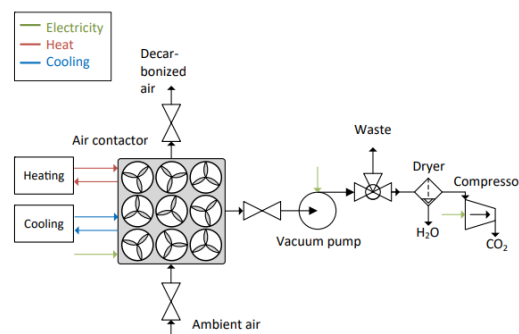

Figure 37. Solid adsorption direct air capture layout [2].

S-DAC relies on modularity to ensure a rapid scale-up. Current modular CO<sub>2</sub> collector containers have a nominal capacity of 500 tons/year [3].

The liquid absorption process (L-DAC) is being commercially led by Carbon Engineering. The technology involves capturing CO<sub>2</sub> from ambient air by chemical interaction with a capture solution, potassium hydroxide (KOH), combined with a caustic calcium regeneration process. An air contactor serves as the interface where ambient CO<sub>2</sub> is brought into contact with the capture solution, allowing for the chemical absorption of CO<sub>2</sub>. The efficiency of this interaction heavily depends on two critical parameters: the liquid-to-gas ratio and the management of pressure drop. An insufficient liquid-to-gas ratio may result in incomplete CO<sub>2</sub> capture, while an excessive ratio can lead to inefficiencies and increased operating costs. In the existing literature, the liquid-to-gas ratio within the air contactor is notably absent as a widely reported parameter, despite its evident significance in direct air carbon capture processes.

Hydrated lime (Ca(OH)<sub>2</sub>) is added to the solution in a causticiser to precipitate captured CO<sub>2</sub> as limestone (CaCO<sub>3</sub>) and regenerate the caustic solution. Limestone is sent to the calciner where CO<sub>2</sub> and calcium oxide (CaO) are released as calcination products (Figure 38). Finally, a concentrated CO<sub>2</sub> stream exits the calciner while CaO is recycled back to the slaker where hydrated lime is regenerated. The calcination process requires heat at 850-900°C, which in the process of Carbon Engineering is produced by burning natural gas. The technology will produce substantial amounts of high-temperature waste heat from the calcination process [4][5].

In addition to natural gas, the liquid absorption and high temperature calcination process use substantial amounts of electrical energy for air fans, solvent pumps, CO<sub>2</sub> capture/oxy-fuel plant, CO<sub>2</sub> compressor, etc. researchers state that 366 kWh of electricity combined with 5.66 GJ of natural gas is necessary to capture one ton of CO<sub>2</sub>. Furthermore, make-up of 5 kg of limestone and KOH per captured ton of CO<sub>2</sub> will also be required. L-DAC plants with 1Mt/y CO<sub>2</sub> capacity expect 8.2 Mt/y of water make-up to compensate for water loss. [5].

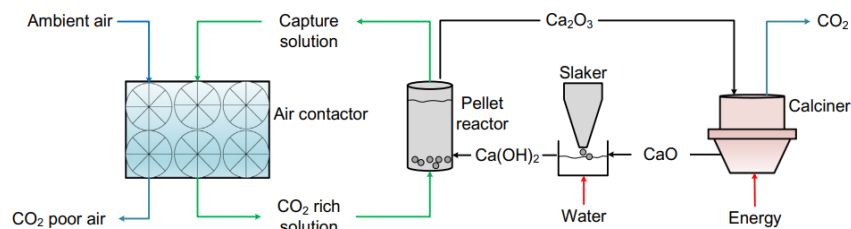

Figure 38. Liquid absorption direct air capture process flowsheet [6].

Currently, research focuses on heating sources flexibility for the calcination process: electricity, hydrogen and biomass could provide decarbonization routes [7][10]. In addition, the first 1 Megaton plant employing the L-DAC principle is scheduled to begin its initial phase start-up by late 2024, highlighting the potential significance of L-DAC systems in future net-zero trajectories, despite their current contentious reliance on natural gas. This potential stems primarily from the imperative need to deploy this technology and expedite the learning curve in order to meet the climate goals from the Paris Agreement (2015). The reduction of capital expenditure (Capex) and operational expenditure (Opex) for DAC is contingent upon infrastructure development and learning from mistakes.

### DAC novel concepts

Emerging designs aim to accelerate the path towards gigaton-scale removal by tackling DAC major obstacles. These novel concepts seek to enhance the efficiency and cost-effectiveness of DAC technologies, which will be key to reduce cost of

capture. Innovative approaches strive for simple and modular designs with lower energy demand. Moreover, alternative sorbents are proposed to optimize cycle times and reduce both capital and operating costs.

**Table 16. Direct Air Capture emerging concepts**

Concept	Method	Challenges	Reference
Electro-swing Adsorption	The adsorbent material acts as the capture material and the heating agent due to its high CO <sub>2</sub> affinity and electrical conductivity.	Reduce the heat loss in the adsorbent and electrodes, reduce the time of cooling step. Development of techno-economic and life cycle analysis. Provide lifetime of sorbent.	[8]
Aqueous Amine DAC	Aqueous amines have shown similar percentage capture as commonly suggested liquid sorbents for DAC (e.g. hydroxides). Their lower regeneration temperature could result in potential energy savings.	There are few studies on their application in DAC. Amine evaporative loss would lead to toxic emissions and poor economics. Recent process modelling work on DAC showed that additional plant would be required to reduce such evaporative losses, and that amines with negligible vapor pressures are necessary to reduce capital costs.	[9]
MOF DAC	Solid porous adsorbents metal-organic frameworks have emerged as a group of potentially very efficient materials to capture CO <sub>2</sub> .	A very limited number of MOFs have been investigated under atmospheric CO <sub>2</sub> concentration. MOFs synthesis on a large scale can become cost intensive. CO <sub>2</sub> capture capacity and selectivity under humid conditions are some of the concepts that research groups are pushing to upgrade.	[10]

<p>Bipolar membrane electro dialysis DAC</p>	<p>CO<sub>2</sub> is recovered in a BPMED stack where CO<sub>2</sub> is recovered from rich streams through ion transport across membranes driven by a difference in electric potential.</p>	<p>Process expenses should be a focal point for enhancement. Future advancements should prioritize the enhancement of electrical conductivity and general durability of ion-exchange membranes, given that the energy consumption of BPMED and the need for membrane replacement significantly impact the economic aspects of the process.</p>	<p>[11]</p>
<p>Moisture Swing Adsorption</p>	<p>The regeneration step mainly consists of moisture swing adsorption, where the adsorbent material releases the CO<sub>2</sub> in the presence of water vapor. In order to minimize energy demands, the DAC system makes use of air convection currents. Fan energy is replaced with natural ambient wind</p>	<p>Performance is affected by atmospheric conditions. Wind intermittent nature needs to be monitored.</p>	<p>[9]</p>

**The role of DAC in meeting net zero goals**

Capturing CO<sub>2</sub> directly from the air and permanently storing it removes the CO<sub>2</sub> from the atmosphere, providing a solution to balance emissions that are difficult to avoid. Emissions from heavy industry and the transportation sector remain the most difficult to tackle. Moreover, DAC offers a way to alleviate anthropogenic emissions from the past.

In April 2022, the International Energy Agency (IEA) stated in their Net Zero Emissions by 2050 Scenario that DAC technologies global CO<sub>2</sub> demand will be higher than 85 Mt of CO<sub>2</sub> in 2030 and around 980 Mt CO<sub>2</sub> in 2050 (Figure 39), requiring a large and accelerated scale-up from today’s capture capacity (Figure 40). The report insists on DAC role as one of the few solutions available to reduce emissions in aviation, which remains one of the most challenging energy sectors to decarbonize. Furthermore, the Intergovernmental Panel on Climate Change (IPCC) concluded their Sixth Assessment Report (AR6) with a synthesis report on March 2023 which encompasses projections and scale-up scenarios for DAC and biomass technologies. These reports offer valuable insights into the potential roles and advancements of these technologies in the context of addressing climate change and achieving sustainable carbon management.



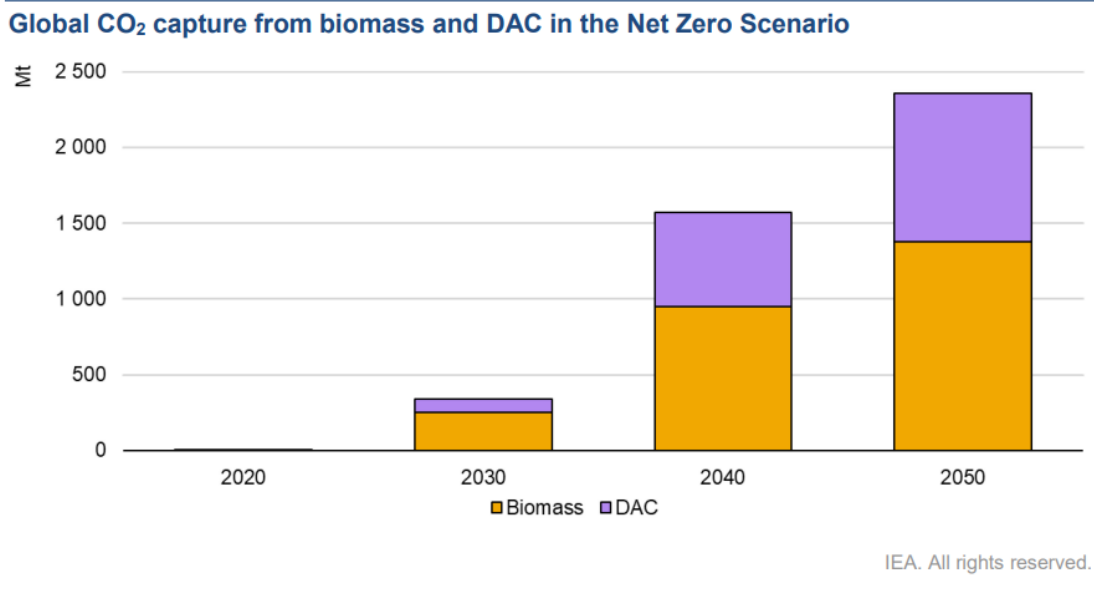

Figure 39. DAC global CO<sub>2</sub> capture demand in the Net Zero Scenario [12].

### Today's DAC deployment

Eighteen DAC plants are operating globally on a demonstration scale. They are located in North America and Europe. Most of these plants have low capacities (1 to 50 t CO<sub>2</sub>/year) and sell the captured CO<sub>2</sub> for use: chemicals, fuels, carbonation and plant yield boosting in greenhouses [12].

In Iceland, Climeworks (S-DAC) and Carbfix are capturing CO<sub>2</sub> from the atmosphere and subsequently storing it underground by injecting the captured CO<sub>2</sub> in basaltic rock formations. This is the first operating application of this type, using the mineralization principle to convert CO<sub>2</sub> into rocks within a couple of years. The plant captures 4,000 tCO<sub>2</sub>/year, making “Orca” the DAC plant with the world’s highest capture capacity to date [3].

The first Megaton-scale DAC plant is now being financed and developed in the United States by 1PointFive (a development company owned by Oxy Low Carbon Ventures). The plant, which will use Carbon Engineering’s DAC technology (L-DAC), will have the capacity to capture up to 1 Mt CO<sub>2</sub> per year and could become operational in its early phase by late 2024 [13].

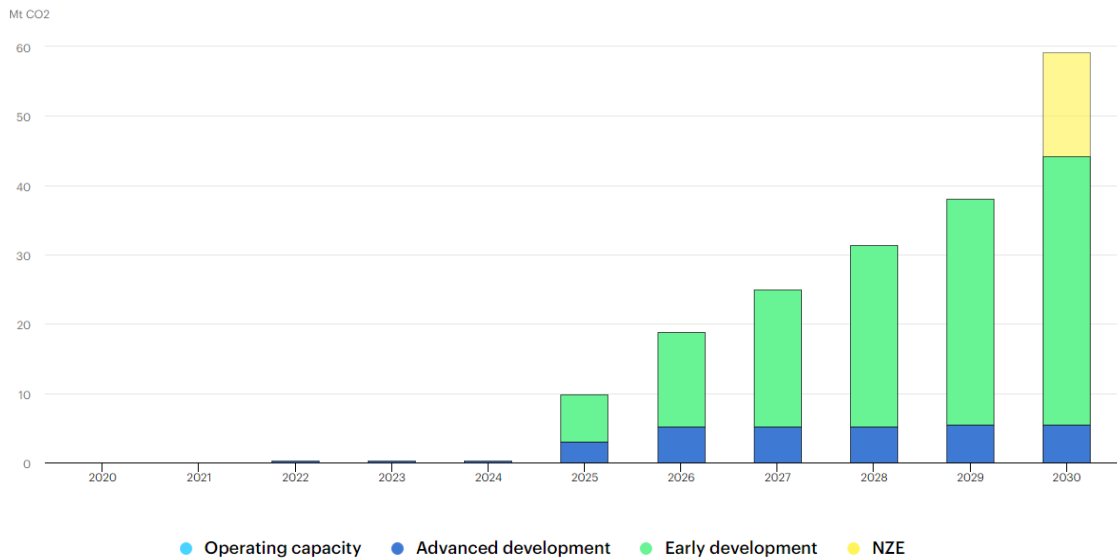

Figure 40. Direct air capture planned projects cumulative capacity in the Net Zero Scenario, 2020-2030 [12]. (NZE = Net Zero Emissions.)

In June 2022, 1PointFive and Carbon Engineering announced plans to deploy 70 large-scale DAC facilities by 2035, each one with an uptake of up to 1 million tons per year. On the other hand, Climeworks announced the construction of their largest plant to date, Mammoth, with a capture capacity up to 36000 t CO<sub>2</sub>/year. The plant is planned to be operational by 2024 [12][5].

DAC deployment could reach around 5.5 Mt CO<sub>2</sub> by 2030 if all the eleven current planned DAC projects are developed successfully. Nonetheless, this is less than 10% of the level of deployment needed to follow the emission mitigation path defined by the Net Zero Scenario.

### Input

DAC processes require air, electrical energy for the air fans, vacuum pumps/compressors, cooling water pumps and possible cooling tower. On one hand, S-DAC systems need activated solid filters and relatively low temperature input (around 100 °C) for the CO<sub>2</sub> desorption. On the other hand, L-DAC technologies tend to have a liquid solvent loop and a high temperature source for its regeneration. For the Carbon Engineering process for L-DAC, lime and water make up streams are needed. Moreover, natural gas is the energy source for the calciner. Energy requirements are given in **Fejl! Henvisningskilde ikke fundet.** Note that the literature suggests future L-DAC plants can be fully electrified, where renewable electricity can replace natural gas as an input. Hydrogen can also be an alternative future energy input.

Table 17. DAC main input parameters [4][14].

	S-DAC	L-DAC
Heat (GJ/tCO <sub>2</sub> )	7.2-9.5	5.5-8.8
Regeneration temperature (°C)	60-100	~900
Electricity (MWh/tCO <sub>2</sub> )	0.8	2.3
Electricity for compression only (MWh/tCO <sub>2</sub> )	0.11 <sup>a</sup>	0.11 <sup>a</sup>

<sup>a</sup> Compression pressure of 150 bar.

## Output

The main output of the DAC process is a concentrated CO<sub>2</sub> stream with relatively high purity. The CO<sub>2</sub> is typically available at low pressure (0.14 to 4 bar) and contains moisture. The CO<sub>2</sub> will need to undergo further compression and dehydration to meet specifications for CO<sub>2</sub> transport or utilisation as most other CC technologies. Depending on the type of DAC process the compression and conditioning equipment is installed in the captured facility. Carbon engineering liquid absorption process cools and compresses the CO<sub>2</sub> concentrated stream to approximately 40°C and 150 bar ready for storage. Moreover, prior to CO<sub>2</sub> separation and conditioning, the calciner outlet stream (T=900°C) goes through a couple of heat exchangers to transfer thermal energy to other process streams. This results in a hot outlet stream (T=315°C) heading to water knockout stage, where washing water cools the stream from 315 to 21°C while CO<sub>2</sub> exists the column on top [4]. Hence, high temperature waste heat is available for potential energy integration applications.

Commercial solid adsorption systems do not include compression and liquefaction stages for underground storage in their designs [15][16]. For instance, Climeworks collaborates with Icelandic company Carbfix to compress the captured CO<sub>2</sub> from air and inject into basaltic rock formations [17]. Hence, it is very common to find cost estimates for S-DAC where compression and conditioning of the downstream CO<sub>2</sub> is neglected. This work takes as reference Carbfix CO<sub>2</sub> injection activities, which present pressure ranges of 70 to 200 bar (See Data sheet). The low temperature process will also produce pure water recovered from the air.

## Energy balance

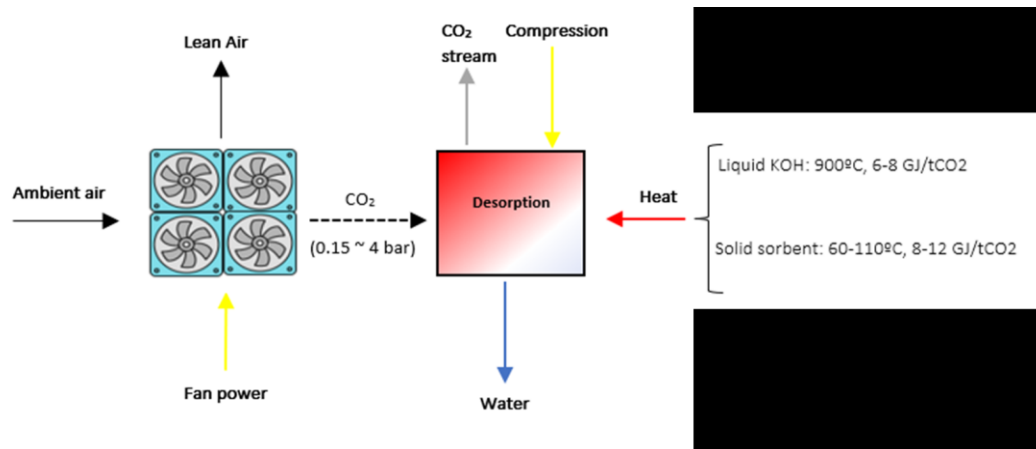

**Figure 41. DAC energy balance diagram.** Yellow arrows represent electrical energy. Black arrows stand for the air streams entering the system and the red arrow the heat requirements for CO<sub>2</sub> desorption.

## Application potential

The contribution of DAC goes beyond carbon removal. DAC technologies can help heavy industry and the transportation sector become climate neutral. Those are sectors historically difficult to decarbonize and thus DAC can adopt an important role in fulfilling net zero targets. Besides acting as a pivotal CDR approach, DAC can be envisaged as a source of climate-neutral CO<sub>2</sub> needed for a range of products that require a source of carbon. Atmospheric CO<sub>2</sub> can take part in several established industrial routes, from beverages to chemicals and synthetic fuels. By 2050 around 350 Mt of air-captured CO<sub>2</sub> is expected to be used to produce synthetic fuels according to the NET Zero Emissions Scenario by the IEA [12]. DAC systems' flexibility of location allows to place capture facilities close to the site of utilization or storage, reducing the need for CO<sub>2</sub> pipeline infrastructure and CO<sub>2</sub> transportation costs. Furthermore, DAC technologies can be placed close to heat available, from industrial waste heat to power plants and geothermal heat.

### Typical capacities

DAC systems capture capacity can vary according to the type of sorbent technology. Solid adsorption displays a modular approach with an estimated 50 tCO<sub>2</sub>/year per unit. Climeworks Orca plant assembles its DAC capture modules in eight collector containers with an annual capacity of 500 tons each [3]. On the other hand, liquid solvent systems tend to be built as large-scale facilities with a centralized solvent regeneration unit. Capture capacities for this type of plants range from 0.5 to 1 Mt CO<sub>2</sub>/year [12].

Operational DAC plants show a wide range of different capture capacities because of DAC concept being in its early stages.

- Climeworks has around 15 operational plants across Germany, Italy, Switzerland and Iceland (built from 2015 to 2021). They combine storage and PtX solutions as main routes for CO<sub>2</sub> utilization, but the beverage industry and greenhouse fertilization are their main market applications to date. Plant capacities range from 3 to 50 and 4000 tons of CO<sub>2</sub> per year.
- Carbon Engineering has built one operational plant in Canada for PtX applications. Their plant captures around 365 tons CO<sub>2</sub> per year.
- The American company Global thermostat has a total of two operational plants capturing 500 and 1000 tons CO<sub>2</sub> per year respectively.



Figure 42. Climeworks largest direct air capture plant located in Iceland [3].

### Space requirement

The land footprint of DAC is smaller than its biological-based CDR analogous such as afforestation [12]. The choice of DAC technology affects the space required for the capture facility. For a 1 million tons capture estimation, L-DAC systems would require approximately 0.4 km<sup>2</sup>, whereas S-DAC plants would need a surface area in the range of 1.2-1.7 km<sup>2</sup>. In both cases the area occupied by the energy source is excluded from the estimations. Nowadays, Climeworks Orca plant requires a land area of 0.0016 km<sup>2</sup> to remove 4,000 tons of CO<sub>2</sub> from the air every year [3].

One of the most decisive factors for DAC technologies space requirement is the choice of energy source. Geothermal and natural gas from the grid can add an additional 13140 m<sup>2</sup>/t CO<sub>2</sub> output/h. Conversely, employing fluctuating renewable technologies largely increases the land footprint. Table 18 shows the land footprint of the renewable energy systems feeding the different DAC systems [15][12].

**Table 18. Land area requirements for different combinations of DAC systems and energy sources. Literature values provided in km<sup>2</sup>/Mt CO<sub>2</sub> are converted to m<sup>2</sup>/t CO<sub>2</sub> output/h.**

	S-DAC	L-DAC
<b>Capture facility</b> (m <sup>2</sup> /t CO <sub>2</sub> output/h)	~10500	3500 <sup>a</sup>
<b>Wind</b> (m <sup>2</sup> /t CO <sub>2</sub> output/h)	574700	119100 <sup>b</sup>
<b>Solar PV</b> (m <sup>2</sup> /t CO <sub>2</sub> output/h)	201500-299600	62200 <sup>c</sup>

<sup>a</sup>Natural Gas used as energy source for the calciner. <sup>b, c</sup>Combination of renewable input and Natural Gas for the solvent regeneration energy requirements.

## Regulation ability

It is important to note that the regulation of DAC systems is an active area of research and development. Advancements in DAC technology aim to improve the flexibility, controllability, and response times of these systems to better align with the changing demands and requirements of the energy and environmental sectors. DAC plants aim for steady supply of low carbon electricity in order to operate in baseload to compensate for high capital investments and decrease cost of capture. This is one of the reasons why Climeworks is operating their first commercial plants in Iceland, where they can leverage cheap and consistent geothermal energy.

Overall, the regulation ability of DAC systems can be enhanced through innovative system designs, operational strategies, and integration with other components of the carbon management infrastructure.

## Production Change Speed

The production change speed in a DAC system can be influenced by its design and operational flexibility. Modular and scalable designs, where the capacity can be easily adjusted by adding or removing units, allow for quicker changes in CO<sub>2</sub> removal rates.

The characteristics of the adsorbent materials used in the DAC system, such as adsorption and desorption kinetics, can affect the production change speed. Some materials may have faster response times, enabling quicker adjustments in CO<sub>2</sub> removal rates [18].

## Start-up time

The start-up time of DAC technologies is dependent on system conditioning and heating/cooling cycles. The duration of the conditioning periods may vary according to the system design, thermal mass of the components and the specific sorbent materials employed [19].

## Environment

DAC displays lower land and water footprint compared to other CDR solutions. DAC water requirements vary with the choice of sorbent. For S-DAC applications, water can be captured simultaneously with CO<sub>2</sub> depending on the type of solid sorbent employed. Hence, net water production can occur by employing S-DAC systems. On the contrary, L-DAC needs water for its continuous operation. Current estimations place the amount of water required for 1 Mt L-DAC system up to 8 tons of water per ton of CO<sub>2</sub> captured from the atmosphere, while S-DAC is thought to produce 0.8-2 tons of water per ton of CO<sub>2</sub> captured [20]. These values may vary according to ambient conditions. S-DAC operation in dry climates could sufficiently provide water to an electrolyser if employing the solid adsorption process. Conversely, under humid conditions (high moisture concentration) water capture might be hindered due to air saturation conditions. Regarding L-DAC, hot and dry climates increase water evaporation rates, resulting in a larger water footprint. Thus, L-DAC operates best in locations with abundant water [4][**Fejl! Bogmærke er ikke defineret.**][21]. Recent studies suggest that materials used for solid sorbent DAC typically perform best in humid and cold conditions. High ambient temperature or low humidity affect the CO<sub>2</sub> capture by the filter material, leading to higher energy consumption and lower CO<sub>2</sub> productivity [22].

Appropriate environmental impact studies should be developed to guarantee overall DAC sustainability. The most crucial factors of concern for DAC in terms of their environmental impact include the selection of energy sources, the acquisition of materials, the management of waste, and the potential alterations in land use. [Fejl! Bogmærke er ikke defineret.]. The IEA has provided estimates for DAC technologies emission factors; S-DAC emits between 0.03 and 0.91 tons of CO<sub>2</sub> for every captured ton, while L-DAC releases 0.1-0.4 tons of CO<sub>2</sub> for every captured ton without considering upstream emissions [12]. These wide ranges show the uncertainty that comes along with DAC technologies. Nonetheless, high emission factors could be related to laboratory and pilot scale designs that use high carbon electricity for operation. On a separate note, the research conducted by J. Wang, S. Li, S. Deng, et al. in 2023 presents a comprehensive study that compiles various emission factors from DAC systems powered by different energy sources.

**Table 19. Greenhouse gas emissions throughout the life cycle per unit of CO<sub>2</sub> captured by Direct Air Capture (DAC).** HTHP stands for High Temperature Heat Pumps.

DAC technology	Energy source	CO <sub>2</sub> -equivalent emissions <sup>a</sup> kg/kg
L-DAC	Fossil-based electricity supply	0.14
L-DAC	Nearly carbon-free electricity supply	0.04
S-DAC	Wind electricity	0.049
S-DAC	HTHP+PV	0.111-0.206
L-DAC	Natural Gas	0.588
S-DAC	Waste heat+grid	0.0337-0.2
L-DAC	Waste heat+PV	0.0774-0.150

This table provides valuable insights into the environmental impact and carbon footprint associated with DAC technologies under varying energy supply scenarios, contributing to the understanding of sustainable carbon capture and management strategies. Understanding emission factor ranges is vital for policymakers and stakeholders seeking to implement effective climate mitigation strategies.

## Advantages and disadvantages

Advantages:

- Low land footprint compared to other CDR technologies.
- Site flexibility is one of DAC's core advantages.
- The possibility of sitting the capture facility close to storage or utilisation sites drastically allows to reduce the capital investment on CO<sub>2</sub> infrastructure.
- It is assumed that DAC follows the same cost reduction principle as solar PV, electrolyzers and batteries. Learning rates for modular technologies are normally between 15-25%, hence, rapid cost scaling is feasible. Modular technology manufactured via automated processes and at high volumes allows expertise to spill from one sector to

another. In other words, it is believed that excellence from solar PV and batteries could be transferred to DAC. Predictions claim that DAC CAPEX could be five times lower by 2050 if the climate goals of the Paris Agreement are met [12].

Disadvantages:

- Technology maturity is one of DAC's most considerable drawbacks, due to the concept still being in its early stages. DAC commercial designs have a technology readiness level (TRL) of 6-7, whereas point source CC has a TRL of 8-9 for widespread commercial use concepts [23].
- DAC is a highly energy intensive carbon removal solution.
- Climate conditions can affect DAC systems performance.
- L-DAC systems can suffer from water loss and solvent evaporation in hot and dry climates. As a result of water and solvent evaporation, large make-ups need to be arranged for DAC to operate under such climate conditions [21].
- Large solvent flows and sorbent filter replacement increase DAC operation and maintenance costs and complexity.

### Research and development perspectives

Nowadays researchers are working on decreasing DAC energy requirements and overall cost of capture to ensure a rapid and successful technology scale-up. The most relevant areas of study and development are [24]:

- **Air contactor technology:** Improvements in the design of the air contactor seek to increase capture rates while reducing fan power and materials cost regarding its construction. Particular attention is being paid to passive air contactors, where fan power is substituted by natural wind convective flows. Increased surface area compensates for a lack of forced airflow, and design optimizations (like vertical stacks) anticipate to play a substantial role in the cost reduction task for scale-up systems.
- **Solvent technology:** Developing solvents with improved kinetics, mass transfer, and lower production costs remains one of the cornerstones of DAC research. Low-cost alkaline materials, MOF, and a variety of biologically enhanced capture mechanisms are alternative options targeted by researchers with the aim of lowering lower energy requirements, deliver faster cycle times and the potential for built-in, permanent CO<sub>2</sub> storage.
- **Novel designs:** Alternative desorption mechanisms are being studied by research groups with the aim of reducing the energy requirements to separate de captured CO<sub>2</sub> from the sorbent material. Applying electrical fields or using bipolar membrane for L-DAC are some of the emerging DAC concepts gaining momentum.
- **Modularity:** Building smaller DAC units thought to be assembled to form larger capture containers emerges as the leading approach to ensure a successful and rapid technology scale-up. Modularity allows to produce components and designs at a high volume for off-the-shelf purchase. DAC companies can mainly rely on external supply chains rather than building from the start each time. Thus, the industry can accelerate its learning rate by producing and assembling large volumes of standardized parts, dropping the cost curve in the process. S-DAC systems are completely modular, while L-DAC has a centralized CO<sub>2</sub> regeneration stage. However, novel L-DAC designs employing bipolar membranes or electrochemistry to regenerate the solvent could potentially seek to implement modular designs.



- Plant siting: Understanding DAC performance as function of plant location is one of the main research areas. Further testing is required to define siting flexibility limitations. CO<sub>2</sub> capture from air may vary from extremely dry or humid conditions to polluted climates as previously discussed in Environment section.

### Examples of market standard technology

Table 20. Examples of commercial DAC companies Part I.

	Technology	Method	Scale	Mission	Future scope	Reference
Carbon Engineering	Absorption (L-DAC)	Potassium hydroxide solution	Pilot	Reach the 1 Mt scale plant	Construction of the 1Mt CO <sub>2</sub> capture plant in Texas by late 2024	[25]
Climeworks	Absorption (S-DAC)	Temperature swing using solid sorbents	Large	To build a multi-megaton capacity by 2030 and gigaton capacity by 2050	Climeworks has set an ambitious target of removing 225 MtCO <sub>2</sub> /yr in the near future	[3]
CarbonCapture	Absorption (S-DAC)	Use of zeolites and other solid sorbent materials in molecular sieves	Pilot	To reduce the cost to \$100/t <sub>CO2</sub> captured at the end of this decade	Project Bison: 5 Mt Carbon removal facility in Wyoming	[26]
Carbon Collect	Passive adsorption (S-DAC)	The wind carries the CO <sub>2</sub> that enters in contact with the sorbent tiles from the mechanical tree	Pilot	-	Carbon Collect aims to capture 3.8 MtCO <sub>2</sub> /yr by scaling the technology in Arizona	[27]
Carbon Infinity	Absorption (S-DAC)	Carbon infinity studies the use of MOFs to reduce the cost-effective of DAC	-	-	To commercialise DAC modules by the end of 2023	[28]
Global Thermostat	Absorption (S-DAC)	Temperature swing using solid sorbents	Pilot	-	Global thermostat aims to implement scale plants with a capacity of 4000 MtCO <sub>2</sub> /yr	[29]
Heirloom Carbon	Calciner	Loop cycles of carbonation and decarbonation of MgO or CaO to separate the CO <sub>2</sub>	Bench	To remove 1 GtCO <sub>2</sub> from the air by 2035 with the most efficient DAC system	Heirloom plans to capture a ton of CO <sub>2</sub> per day in 2022	[30]

Table 21. Examples of commercial DAC companies Part II.

Company	Technology	Method	Scale	Mission	Future scope	Reference
Sustaera	Electro-swing adsorption	Use of an alkali metal based solid to enhance the capture.	Pilot	To remove 0.5 GtCO <sub>2</sub> by 2040	In 2023, they plan to establish partnerships to scale a 10 tCO <sub>2</sub> /day plant	[31]
Mission Zero	Electro-chemical separation	Use of a water-soluble solvent that require 4 times less energy than current hydroxide base solvents	Bench	2022: An industrial scale pilot to remove 365 tCO <sub>2</sub> /yr	In 2022, the company aims to scale an industrial pilot plant to remove 365 tCO <sub>2</sub> /yr. In 2023, the company will improve its capacity to 1 ktCO <sub>2</sub> /yr	[32]
Noya	Absorption (L-DAC)	Chemical blend added to the water content in a cooling tower	Pilot	To scale their technology in 2 million of cooling towers to pull around 8.5 GtCO <sub>2</sub> /yr	The company aims to minimise the cost per tonne by maximising the CO <sub>2</sub> production	[33]
Verdox	Electro-swing adsorption	Use of quinones connected to a ferrocene	Bench	To reduce a 70% the cost from the present DAC systems	The company expects demonstrate the feasibility of their method by scaling-up a pilot plant in the next years	[34]
Carbyon	Fast-swing adsorption	Monolayer of solid sorbent. Rotation drum. Carbon fibers conduct electricity to desorb CO <sub>2</sub>	Bench	Reach Mt scale by 2030	The company seeks to adopt a modular and user centered business model like solar panels companies	[35]

## Prediction of performance and cost

Commercial DAC companies have not publicly shared their capital investments, nor the operational costs related to their carbon removal activities. Thus, current state of the art cost estimations is based on theoretical assumptions and pilot plant performance data presented in [20]. This section covers the cost estimation for theoretical L-DAC and S-DAC plants with a total capture capacity of 1 MtCO<sub>2</sub>. Technical data is found in the data sheet under 2025 for L-DAC and under 2030 for S-DAC, as these years correspond to the expected date of achieving 1 MtCO<sub>2</sub> capture capacity for each technology [36][37]. Hence, note that costs for 2020 in the data sheet come from a combination of data from current operating plants and merely theoretical as plants have not reached a larger scale yet. Cost estimates for both DAC approaches do not include costs for compression, transportation, injection, and sequestration. The rest of the model assumptions are comprised in the table below:

Table 22. Model assumptions for performance and cost prediction of DAC systems [20].

Assumption	L-DAC	S-DAC
Plant capacity (Mt CO <sub>2</sub> )	1	1
Capture fraction (%)	75	65-75
Concentration of output CO <sub>2</sub> (%)	~ 98	~ 99
Sorbent purchase cost	No	CAPEX
Sorbent replacement cost	No <sup>a</sup>	OPEX
Electricity Cost (\$/MWh)	60	60
Compression of CO <sub>2</sub>	No	No

<sup>a</sup>L-DAC sorbent replacement is included in the make-up streams section.

Total capital and operational costs of DAC systems consist of numerous integration costs that emanate from the main stages of the process. Liquid solvent DAC has more cost components than the solid adsorption process, due to the liquid solvent regeneration stage being more sophisticated. Operating costs encompass the maintenance and labor for the various equipment components and capture facility. They are generally dominated by fan power, due to the need to process large flows of air and overcome the subsequent pressure drop.

As discussed in earlier sections, the choice of energy source will have a substantial impact on the capture cost of DAC systems. DAC being in its early stages of development has prevented vendors from providing official statements on energy sources cost for atmospheric CO<sub>2</sub> capture.

#### L-DAC systems cost estimates

L-DAC cost data is based on Carbon Engineering liquid absorption process powered by different energy sources i) current configuration that consists of a combination of electricity and natural gas, ii) green hydrogen as potential replacement for natural gas and iii) complete electrification of the system powered by renewables. The objective is to provide insights regarding low-carbon energy sources impact on direct air capture cost.

Assumptions behind the cost estimates are described in Table 23. Capital and operating costs for a 1 Mt/y CO<sub>2</sub> L-DAC plant are provided in Table 23 and Table 24 respectively. Capital costs include the prices of equipment units that comprise the DAC system. Unlike sorbents, Table 23 components do not experience degradation because of weather conditions and other outside factors [4]. Note that CAPEX for a H<sub>2</sub>-fired calciner process are included in this table. Hence, costs of electrolyzer for H<sub>2</sub> production are present to illustrate the increase in CAPEX for a L-DAC plant based on renewable energy sources. The compressor and pressurized storage tank for on-site H<sub>2</sub> storage are not included in this table.

With an oxy-fired calciner CAPEX is between 675 and 1,255 \$M (corresponding to an investment of 4.7 to 8.7 M€ / (tCO<sub>2</sub> /h)), whereas CAPEX for a H<sub>2</sub>-fired calciner is between 1,920 and 3,045 \$M according to [20] and thereby significantly higher than the former type of plant. For the CAPEX values in the data sheet these numbers are consolidated with [38].

**Table 23. CAPEX of a liquid absorption DAC system with a total capture capacity of 1 Mt CO<sub>2</sub> per year [20].** (CAPEX is presented for both oxy-fired calciner process and hydrogen-powered calciner process.)

L-DAC CAPEX	Oxy-fired calciner cost (\$M)	H <sub>2</sub> -fired calciner cost (\$M)
Contactarray	210–420	210–420
Slaker, causticizer, clarificator	130–195	130–195
Air separation unit and condenser	65-100	
Oxy-fired Calciner	270–540	
H <sub>2</sub> -Fired Calciner		360–720
Electrolyzer		260–420

The operational costs largely depend on the heat and electricity prices as well as the energy source (e.g. natural gas or hydrogen). Table 24 shows OPEX cost distribution per tCO<sub>2</sub> captured according to [20]. Maintenance and labour costs are under fixed operational costs in the data sheet. Makeup streams and waste removal is included in the data sheet under variable operational costs with 5 \$/t CO<sub>2</sub> output.

**Table 24. OPEX of a liquid absorption DAC system with a total capture capacity of 1 Mt CO<sub>2</sub> per year [20].**

L-DAC OPEX	Cost (\$/t CO <sub>2</sub> )
Maintenance	18-33
Labor	6-10
Makeup streams <sup>a</sup> and waste removal	5–7

Natural Gas	25–35
Electricity	12–28

<sup>a</sup>Make-up streams consist of H<sub>2</sub>O, KOH and Ca(OH)<sub>2</sub>.

The distribution of liquid solvent direct air capture cost estimates on components are illustrated in Figure 43. The air contactor and the calciner are normally the most capital-intensive component of the system, while solvent capital investments are moderate due to liquid absorption technology maturity.

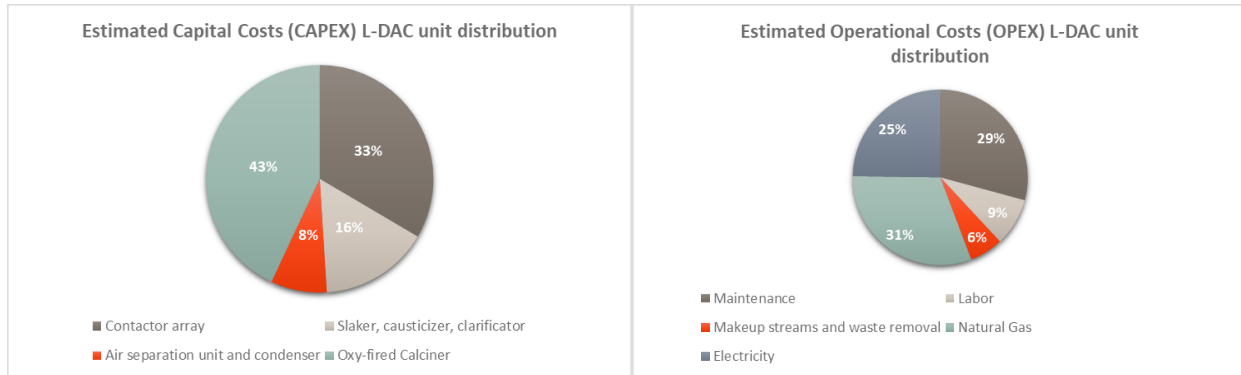

Figure 43. L-DAC systems CAPEX and OPEX component distribution based on [20] estimations.

A capture cost of 147-264 \$/tCO<sub>2</sub> for the natural gas-fired calciner process is reported in [20]. This value strictly considers the cost of removing 1t CO<sub>2</sub> from the air. However, taking the emissions from burning natural gas during capture into account results in a Net-Removed cost of 199-357 \$/tCO<sub>2</sub>. Opting for the H<sub>2</sub>-fired calciner process results in an average net removed CO<sub>2</sub> cost range of 317-501 \$/tCO<sub>2</sub> [20]. As discussed in earlier sections, the choice of energy source will have a substantial impact on the capture cost of DAC systems. DAC being in its early stages of development has prevented vendors from providing official statements on energy sources cost for atmospheric CO<sub>2</sub> capture.

Table 25 shows the levelized cost of capture of L-DAC systems from different works with the aim at defining a scope of work regarding DAC cost of capture. The studies account for CO<sub>2</sub> emissions during capture (net capture cost). Cost variations are likely due to choice of packing material and design configuration. PVC packing paired with crossflow configuration presents lower pressure drop and reduced capital expense compared to conventional metal packing with counter-flow configuration [4].

Table 25. Summary of capture costs from the main works in the literature.

Study	Net Capture Cost (\$/tCO <sub>2</sub> )	References
National Academies of Sciences, Engineering and Medicine report	199-357 <sup>a</sup>	[20]
APS, 2011	641-819	[20]
Mazzotti et al. 2013	510-568	[20]
APS, 2011	610	[20]
Keith et al., 2018	94-232	[4]

<sup>a</sup>Basis = per net unit of CO<sub>2</sub> removed with an average of 0.3 MtCO<sub>2</sub> for natural gas and zero for coal.

Even though cost of compression is neglected, the report [20] suggests that around 8 \$/t CO<sub>2</sub> could be added to the total cost of net removal in order to account for compression in L-DAC systems.

**S-DAC systems cost estimates**

The performance and cost data for the S-DAC process is based on Climeworks technology with waste heat from geothermal-based electric utilities. The assumptions behind the cost estimates are described in table 26. Capital costs for a 1 Mt/y CO<sub>2</sub> S-DAC plant are provided in table 27. The large intervals illustrate the uncertainty. For the CAPEX values in the data sheet these numbers are consolidated with [38], giving an estimate of 815 M€ (or 6.5 M€/(tCO<sub>2</sub> / h)) for a 1Mt CO<sub>2</sub> plant in 2020.

**Table 26. CAPEX of a solid sorbent DAC system with a total capture capacity of 1 Mt CO<sub>2</sub> per year [20].**

S-DAC CAPEX	COST (\$/tCO <sub>2</sub> )
Sorbent	70-186
Contactator	1.3-4.1
Vacuum pump	2.6-8.5
Blower	2.1-6.7
Condenser	0.07-0.1

Regular maintenance is necessary to maintain an adequate level of performance of the S-DAC plant. It includes sorbent replacement, which is currently performed manually and therefore costly. This operation is most notably challenging for S-DAC due to the layout of the system. DAC sorbent replacement rates (0.25-38 kg/tCO<sub>2</sub>) have an impact on operating costs (Figure 44), which could see an increase if replacement frequency raises due to site-specific conditions such as air humidity or pollution [16]. Wide ranges are once again due to DAC uncertainty and technology immaturity. Operation and maintenance costs are mainly fixed for the solid absorption technology, which is reflected in the data sheet.

**Table 27. OPEX of a solid sorbent DAC system with a total capture capacity of 1 Mt CO<sub>2</sub> per year [20]. Adsorption refers to the costs associated with the replacement and maintenance of the sorbent bed.**

S-DAC OPEX	Cost (\$/tCO <sub>2</sub> )
Adsorption	9-29
Steam	2.2-3
Vacuum pump	0.2-0.24

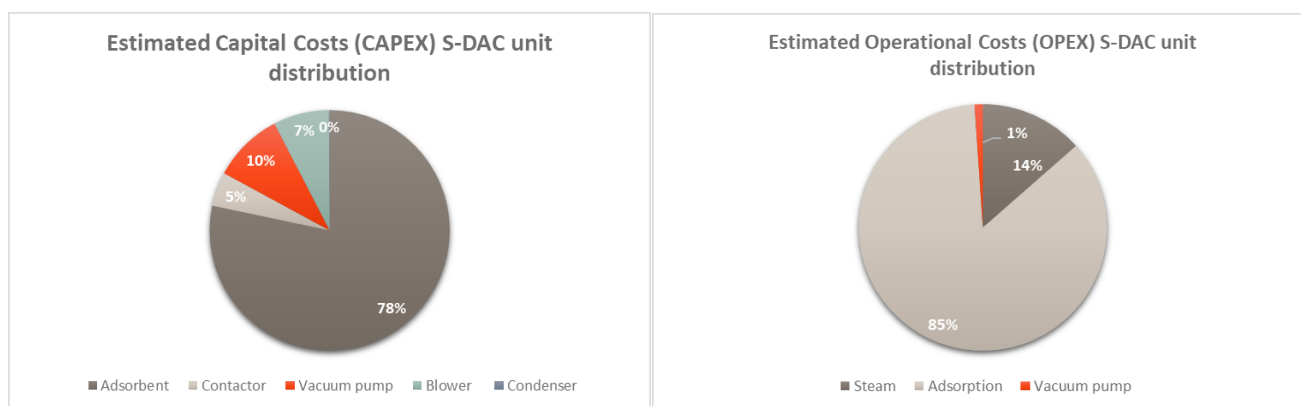

**Figure 44. S-DAC systems CAPEX and OPEX component distribution based on [20] estimations. Adsorption refers to the costs associated to the replacement and maintenance of the sorbent bed.**

The levelized S-DAC system capture costs estimates range from 88 to 228 \$/tCO<sub>2</sub> for a generic solid sorbent direct air capture system that has been scaled up to 1Mt CO<sub>2</sub> capacity (table 28). To put that into perspective, Climeworks currently reports a cost of capture of about 600 \$/tCO<sub>2</sub> for their first-generation (small scale) commercial plant [20]. Furthermore, IEA 2022 cost estimates place cost of capture for large-scale applications (1 MtCO<sub>2</sub>/year) in the range of 25-335 \$/tCO<sub>2</sub>. The cost fluctuation depends on capture technology (L-DAC or S-DAC), price of heat and electricity, plant configuration and CO<sub>2</sub> utilisation. Furthermore, IEA states that a carbon price around 160 \$/tCO<sub>2</sub> could make DAC profitable [12]. Researchers in the field have elaborated exhaustive cost estimates regarding the source of energy for DAC technologies. The work of McQueen et al. 2021 postulated that solar would result in a cost range of 430–690 \$/tCO<sub>2</sub>, while wind energy cost is calculated to be around 360–570 \$/tCO<sub>2</sub>.

**Table 28. S-DAC cost of capture estimates from different works.**

Work	Net Capture Cost (\$/tCO <sub>2</sub> )	References
National Academies of Sciences, Engineering and Medicine report	88 to 228	[20]
McQueen et al 2021	205 to 223	[9]
Sinha and Realff	86–221	[39]
Shayegh et al.	~200 <sup>a</sup>	[40]

<sup>a</sup>Capture cost by 2050

As previously stated, CO<sub>2</sub> compression cost is not considered. However, S-DAC compression costs can be calculated following conventional models employed in point source CC, CO<sub>2</sub> compression, liquefaction and underground storage. S-DAC-CO<sub>2</sub> output conditions allow to appoint cost estimates to these areas, as done in the National Academies of Sciences, Engineering and Medicine report [20].

### Learning curves and technological maturity

DAC is an emerging concept with substantial potential for performance enhancement and cost reduction since it is currently at its early stages (TRL 6-7). The anticipated cost reduction of DAC systems revolves around component improvement, up-graded constructability and well-established supply chains. Improvements can be generally driven by deployment and economies of scale:

- **Economies of scale:** As a company gains experience in producing a particular product or service, it often becomes more efficient over time. It is thought that mass production allows for shared infrastructure and facilities and relies on an optimised supply chain, resulting in equipment cost advantages for the company. From DAC perspective, S-DAC modular units and L-DAC large equipment can become cheaper when produced at a larger scale.
- **Deployment:** Also referred to as learning-by-doing, consists of the gain of crucial knowledge and experience by developing a certain product or activity. L-DAC systems are expected to have a 10% learning rate between 2020 and 2050 due to concept similarity with amine-based point source capture technologies. Alternatively, S-DAC is believed to have a learning rate of around 15%, because of its modular nature.

Learning curves are mathematical tools employed to measure how the cost of a technology decreases as function of the cumulative output increases due to contributions from learning-by-doing and economies of scale. In the DAC field, the standard learning curve approach is implemented for estimating the DAC CAPEX development through the years. Three fundamental input data are required for estimating future DAC system capex: i) initial capex, ii) historic cumulative DAC capacity demand and iii) the learning rates for DAC systems [38].

DAC learning curves studies assume that the targets of the Paris Agreement might be achieved by the middle of the 21<sup>st</sup> century. Current works estimate annual DAC capacity demands for the period 2020 to 2050. The IEA Direct Air Capture Report (2022) assumes three different rates of deployment (10, 15 and 20%) based on Net Zero Scenario. Similarly, the work by L. Jiang et al. (2023) approves the implementation of the two-scenario approach for DAC capex development:

- The conservative scenario assumes 50% realisation of the cumulative DAC capacity demand due to delayed execution of the Paris Agreement and a DAC learning rate of 10% between 2020 and 2050.
- The base case scenario assumes an effective execution of the Paris Agreement without delay. Net zero GHG emissions from the energy system are achieved and CO<sub>2</sub> removal phase has already started. The DAC learning rate is assumed to be 15% between 2020 and 2050.

Literature works tend to deliver capital investment and operational costs from a yearly standpoint in the learning curves prediction. However, in this catalog DAC CAPEX and OPEX are provided in an hourly basis regarding learning curves estimation (Table 29). The low DAC 2020 capex values can hold several interpretations. On one hand, none of the leading commercial companies have publicly shared their CAPEX, hence, theoretical estimations and pilot plant data are the main sources for cost estimation. Secondly, calculations do not account for site specific costs, which can significantly impact CAPEX values [12][20]. On the other hand, actual DAC full load hours might be lower than generally employed assumptions (~8000h). Lower operating hours result in higher CAPEX values.

**Table 29. Capex reduction estimates for both conservative and base case scenarios [38].**

Parameter	Units	2020	2030	2040	2050
L-DAC total CAPEX (conservative)	M€/(tCO <sub>2</sub> /h)	5.84	2.70	1.90	1.59
L-DAC total CAPEX (base case)	M€/(tCO <sub>2</sub> /h)	5.84	1.51	0.88	0.67
S-DAC total CAPEX (conservative)	M€/(tCO <sub>2</sub> /h)	6.52	3.02	2.12	1.78
S-DAC total CAPEX (base case)	M€/(tCO <sub>2</sub> /h)	6.52	1.69	0.98	0.74
Historic cumulative capacity (conservative)	tCO <sub>2</sub> /h	171	53995	546918	1752968
Historic cumulative capacity (base case)	tCO <sub>2</sub> /h	171	27055	273516	--- <sup>a</sup>

<sup>a</sup>Obtained number is not on a plant basis.

From the table it could be extracted that S-DAC systems have lower capital investments than more established technologies as point source carbon capture. It is necessary to elaborate on the fact that Table 29 values are based on optimistic scenarios. Furthermore, S-DAC could potentially present in fact lower CAPEX than other carbon capture technologies. S-DAC capture units are made of cheap materials and can follow automated production processes. Modularity and economies of scale could drive manufacturing costs down. Conversely, building large towers (absorber, washer and desorber) made of more expensive materials and that require laborious manufacturing processes could indeed present higher capital investments.

Moreover, research is putting a lot of effort in optimizing DAC systems to bring the costs down. The air contactor is one of the key elements holding the greatest potential for cost reduction, especially for L-DAC technologies. Reducing pressure drop and increasing packing wetting are the main targets for current commercial cooling tower technology. It is thought that pressure reduction could result in 2/3 decrease in operational energy expenditures on fan power [4]. Generally, novel sorbents with enhanced kinetics and mass transfer, and lower energy consumption are addressed by research groups. Technology spillovers from other areas and applications are believed to play a significant role in sorbent upgrade [12].

### Uncertainty

DAC technologies are still in their early stages of development and have yet to be proved at large scale. Hence, cost estimates on DAC future costs rely mainly on pilot plant data and theoretical assumptions.

The following years will be key in the DAC scale up transition with the completion of two large-scale DAC facilities from the leading vendors Climeworks and Carbon Engineering.

### Quantitative description

A data sheet for liquid and solid sorbent DAC technology has been produced. See separate Excel file for Data sheet.

### References

---

- [1] Habib Azarabadi, Klaus S. Lackner, A sorbent-focused techno-economic analysis of direct air capture, *Applied Energy*, Volume 250, 2019, Pages 959-975, ISSN 0306-2619.
- [2] Francesco Sabatino, Alexa Grimm, Fausto Gallucci, Martin van Sint Annaland, Gert Jan Kramer, Matteo Gazzani, A comparative energy and costs assessment and optimization for direct air capture technologies, *Joule*, Volume 5, Issue 8, 2021, Pages 2047-2076.
- [3] [www.Climeworks.com/technology](http://www.Climeworks.com/technology)
- [4] D. W. Keith, G. H. Holmes, D. St. Angelo, K. Heidel. A Process for Capturing CO<sub>2</sub> from the Atmosphere. *Joule* 2, 1573-1594, August 15, 2018.
- [5] Daniel Casaban, Elena Tsalaporta, Direct air capture of CO<sub>2</sub> in the Republic of Ireland. Is it necessary?, *Energy Reports*, Volume 8, 2022, Pages 10449-10463.
- [6] Junyao Wang, Shuangjun Li, Shuai Deng, Xuelan Zeng, Kaixiang Li, Jianping Liu, Jiahui Yan, Libin Lei, Energetic and Life Cycle Assessment of Direct Air Capture: A Review, *Sustainable Production and Consumption*, Volume 36, 2023, Pages 1-16, ISSN 2352-5509.
- [7] McQueen Noah, Desmond Michael J., Socolow Robert H., Psarras Peter, Wilcox Jennifer, Natural Gas vs. Electricity for Solvent-Based Direct Air Capture, *Frontiers in Climate*, 2, 2021.
- [8] Faradaic electro-swing reactive adsorption for CO<sub>2</sub> capture, Sahag Voskian and T. Alan Hatton, *Energy Environ. Sci.*, 2019, 12, 3530-3547.
- [9] María Erans, Eloy S. Sanz-Pérez, Dawid P. Hanak, Zeynep Clulow, David M. Reiner and Greg A. Mutch, Direct air capture: process technology, techno-economic and socio-political challenges, *Energy Environ. Sci.*, 2022, 15, 1360-1405.
- [10] Shreya Mahajan, Manu Lahtinen, Recent progress in metal-organic frameworks (MOFs) for CO<sub>2</sub> capture at different pressures, *Journal of Environmental Chemical Engineering*, Volume 10, Issue 6, 2022, 108930, ISSN 2213-3437.
- [11] Modeling, Optimization, and Techno-Economic Analysis of Bipolar Membrane Electrodialysis for Direct Air Capture Processes, Francesco Sabatino, Matteo Gazzani, Fausto Gallucci, and Martin van Sint Annaland, *Industrial & Engineering Chemistry Research* 2022 61 (34), 12668-12679.
- [12] IEA (2022), Direct Air Capture, IEA, Paris <https://www.iea.org/reports/direct-air-capture>, License: CC BY 4.0
- [13] [www.1pointfive.com/ector-county-tx](http://www.1pointfive.com/ector-county-tx)
- [14] Madhu, K., Pauliuk, S., Dhathri, S. et al. Understanding environmental trade-offs and resource demand of direct air capture technologies through comparative life-cycle assessment. *Nat Energy* 6, 1035–1044 (2021)
- [15] P. Viebahn, A. Scholz and O. Zelt. The potential Role of Direct Air capture in the German energy research program. *Energies* 2019, 12, 3443.
- [16] A review of direct air capture (DAC): scaling up commercial technologies and innovating for the future, Noah McQueen, Katherine Vaz Gomes, Colin McCormick, Katherine Blumanthal, Maxwell Pisciotta and Jennifer Wilcox, 2021, *Prog. Energy* 3, 032001.



- [17] Technical Report, STATE OF THE ART: CCS TECHNOLOGIES 2022, Global CCS Institute, 2022, <https://www.globalccsinstitute.com/resources/publications-reports-research/state-of-the-art-ccs-technologies-2022>.
- [18] Habib Azarabadi, Klaus S. Lackner, A sorbent-focused techno-economic analysis of direct air capture, *Applied Energy*, Volume 250, 2019, Pages 959-975, ISSN 0306-2619.
- [19] Francesco Sabatino, Alexa Grimm, Fausto Gallucci, Martin van Sint Annaland, Gert Jan Kramer, Matteo Gazzani, A comparative energy and costs assessment and optimization for direct air capture technologies, *Joule*, Volume 5, Issue 8, 2021, Pages 2047-2076.
- [20] National Academies of Sciences, Engineering, and Medicine; Division on Earth and Life Studies; Ocean Studies Board; Board on Chemical Sciences and Technology; Board on Earth Sciences and Resources; Board on Agriculture and Natural Resources; Board on Energy and Environmental Systems; Board on Atmospheric Sciences and Climate; Committee on Developing a Research Agenda for Carbon Dioxide Re-moval and Reliable Sequestration. (2018). *Negative Emissions Technologies and Reliable Sequestration: A Research Agenda*. National Academies Press (US).
- [21] Keju An, Azharuddin Farooqui, Sean T. McCoy, The impact of climate on solvent-based direct air capture systems, *Applied Energy*, Volume 325, 2022, 119895, ISSN 0306-2619.
- [22] Optimal Design and Operation of Solid Sorbent Direct Air Capture Processes at Varying Ambient Conditions, Jan F. Wiegner, Alexa Grimm, Lukas Weimann, and Matteo Gazzani, *Industrial & Engineering Chemistry Research* 2022 61 (34), 12649-12667.
- [23] Global CCS Institute (2021), TECHNOLOGY READINESS AND COSTS OF CCS, <https://www.globalccsinstitute.com/resources/publications-reports-research/technology-readiness-and-costs-of-ccs>.
- [24] Peter Minor, The future of DAC is knocking, *Carbon180.medium*, <https://carbon180.medium.com/the-future-of-dac-is-knocking-168326270d33>, November 2021.
- [25] <https://carbonengineering.com/our-technology/>
- [26] <https://www.carboncapture.com/what-we-do>
- [27] <https://carboncollect.com/mechanical-tree/>
- [28] <https://www.carboninfinity.com/technologies>
- [29] <https://www.globalthermostat.com/solutions>
- [30] <https://www.heirloomcarbon.com/technology>
- [31] <https://www.sustaera.com/technology>
- [32] <https://www.missionzero.tech/our-technology>
- [33] <https://techcrunch.com/2021/02/24/noya-labs-turns-cooling-towers-into-direct-air-capture-devices-for-co2-emissions/?guccounter=1>
- [34] <https://verdox.com/technology>
- [35] <https://carbyon.com/technology/>
- [36] <https://newsroom.climeworks.com/196012-climeworks-takes-another-major-step-on-its-road-to-building-gigaton-dac-capacity>
- [37] <https://carbonengineering.com/news-updates/construction-direct-air-capture-texas/>
- [38] M. Fasihi, O. Efimova, C. Breyer. Techno-economic assessment of CO<sub>2</sub> direct air capture plants. *J. of Cleaner Prod.* 224 (2019) 957-980.
- [39] Sinha, A, Realff, MJ. A parametric study of the techno-economics of direct CO<sub>2</sub> air capture systems using solid adsorbents. *AIChE J.* 2019.
- [40] Shreya Mahajan, Manu Lahtinen, Recent progress in metal-organic frameworks (MOFs) for CO<sub>2</sub> capture at different pressures, *Journal of Environmental Chemical Engineering*, Volume 10, Issue 6, 2022, 108930, ISSN 2213-3437.

## Introduction to CO<sub>2</sub> transport

### Contact information:

- Contact information: Danish Energy Agency: Emil Esketveit Rasmussen emrm@ens.dk; Christoph Wolter chwo@ens.dk.
- Energinet.dk: Rune Duban Grandal
- Author: Jacob Knudsen & Mogens Zoll Hundahl from COWI

### Publication date

2023

### Amendments after publication date

Date	Ref.	Description
-	-	-

## i.1 General

The realisation of a complete carbon capture storage (CCS) and/or utilisation (CCU) value chain will nearly always involve transportation and or interim storage of CO<sub>2</sub>. This is because the CO<sub>2</sub> emission sources and suitable geological storage and/or CO<sub>2</sub> utilisation sites are likely to be geographically separated. Moreover, it may be anticipated that the CO<sub>2</sub> supply from capture facilities and the use at CO<sub>2</sub> utilisation facilities may not always be balanced hence interim CO<sub>2</sub> storage capacity will be required. Likewise, CO<sub>2</sub> buffering capacity may be required when changing from one mode of transportation to another.

This chapter of the technology catalogue will describe liquefaction and intermediate storage in connection to biogas plants and the different technologies available for transportation of CO<sub>2</sub> i.e. the link between CO<sub>2</sub> capture and CO<sub>2</sub> storage/utilisation. The main technologies described are:

- Liquefaction
- Intermediate storage
- Pipeline transport
- Ship transport
- Road transport

The carbon capture technology catalogue briefly describes the capture of CO<sub>2</sub> from large emission sources or ambient air including CO<sub>2</sub> compression and liquefaction technology which will condition CO<sub>2</sub> into a suitable state for transportation.

This chapter only describes the transportation of CO<sub>2</sub> from capture to storage/utilisation site. The technology required for geological storage of CO<sub>2</sub> e.g., CO<sub>2</sub> injection equipment, injection well, etc. or CO<sub>2</sub> utilisation is not covered.

## i.2 CO<sub>2</sub> properties in relation to transport

The physical properties and phase behaviour of CO<sub>2</sub> are important to consider when selecting the design conditions for CO<sub>2</sub> transportation.

To facilitate cost optimal transportation of CO<sub>2</sub>, conditions that enable high CO<sub>2</sub> density is required. High density is obtained by compressing CO<sub>2</sub> to a high-pressure gas/fluid or through liquefaction to liquid state. Solid CO<sub>2</sub> (dry ice) has also high density but solid CO<sub>2</sub> is impractical to handle and store, hence solid-state transportation is not normally considered a viable option.

Figure 45 shows the pressure-temperature phase diagram of pure CO<sub>2</sub>. The critical point for CO<sub>2</sub> is at 31°C and 74 bara, which represents the highest temperature and pressure where a liquid phase can be present. On the lower temperature end of the phase diagram is the triple point of CO<sub>2</sub> -56.6°C and 5.2 bara, which represents the lower temperature and pressure where a liquid phase can be present.

For transport of CO<sub>2</sub> in liquid state e.g., by tanker truck or ship, it thus follows that the temperature must be in the range of -56 to +31°C and the pressure 5.2 to 74 bara. For practical solutions, conditions are restricted to approx. 15 bara and approx. -28°C.

For CO<sub>2</sub> pipeline transport it is normally not desirable to operate at conditions where phase change may occur (gas-liquid). Therefore, pipelines are often operated above the critical pressure of CO<sub>2</sub> (74 bara) to avoid two phase formation. Another important factor is to achieve high density, according to Figure 46.

The CO<sub>2</sub> phase diagram is illustrated in Figure 45. The options for transportation of CO<sub>2</sub> are included.

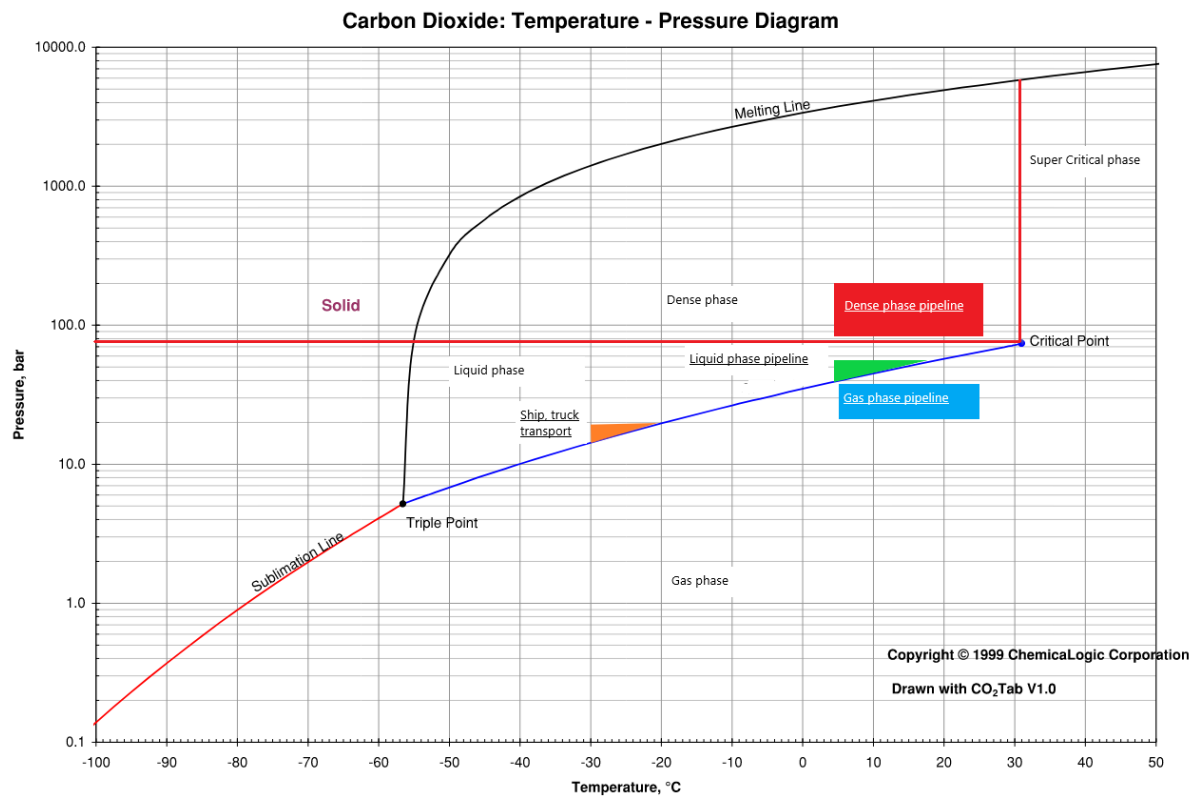

Figure 45. CO<sub>2</sub> phase diagram with the options for liquid-, gas- and dense phase transportation.

Figure 46 illustrates the relationship between pressure and CO<sub>2</sub> density. It appears that a CO<sub>2</sub> pipeline operating above the critical pressure (dense phase) may achieve CO<sub>2</sub> transport densities around 800-1000 kg/m<sup>3</sup> at typical temperatures for buried pipelines in Denmark. This is more than an order of magnitude higher density compared to what is known from the natural gas transmission net, which implies that relatively small pipeline diameters will be required for transport of CO<sub>2</sub>.

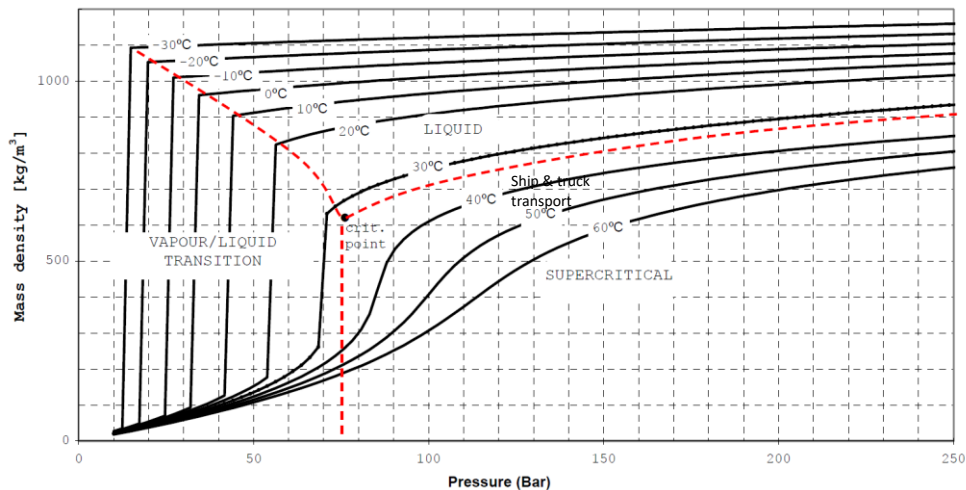

Figure 46. Mass density of pure CO<sub>2</sub> as function of pressure based on Peng-Robinson EQS. Source: DNV-GL RP-J202.

The above diagrams are representative for pure CO<sub>2</sub> only. The presence of other gases or contaminants (O<sub>2</sub>, N<sub>2</sub>, Ar, SO<sub>2</sub>, NO<sub>x</sub>, etc.) will alter the phase behaviour of CO<sub>2</sub> significantly. In general, the presence of contaminants tends to increase the critical pressure and temperature of CO<sub>2</sub>, hence higher pipeline pressures will be required to stay out of the two-phase region.

For liquefied CO<sub>2</sub> the presence of even trace amounts of non-condensable gases e.g., O<sub>2</sub>, Ar, N<sub>2</sub>, etc. will change the physical properties substantially as illustrated in Table 30.

Table 30. Impact of non-condensable gases on vapour pressure of CO<sub>2</sub>.

Mixture	Vapour pressure at -50°C
CO <sub>2</sub> (100%)	6.7 bara
CO <sub>2</sub> mixture with 0.05 mol% N <sub>2</sub>	7.0 bara
CO <sub>2</sub> mixture with 0.1 mol% N <sub>2</sub>	7.3 bara
CO <sub>2</sub> mixture with 0.5 mol% N <sub>2</sub>	9.7 bara
CO <sub>2</sub> mixture with 0.05 mol% O <sub>2</sub>	6.9 bara
CO <sub>2</sub> mixture with 0.05 mol% H <sub>2</sub>	10.3 bara

Furthermore, with liquid CO<sub>2</sub> at low temperatures (cryogenic), the presence of even 100 ppm of water may lead to CO<sub>2</sub> hydrate or ice formation. This can cause severe operational problems such as plugging of valves, heat exchangers, etc. to circumvent such operational issues, CO<sub>2</sub> will be dehydrated to very low water content (typically <30 ppm) prior to liquefaction. Another issue with moisture is that CO<sub>2</sub> will be very corrosive for carbon steel in the presence of small amounts of H<sub>2</sub>O due to the formation of carbonic acid. This is why CO<sub>2</sub> is also dehydrated to low value (low dew point) prior to pipeline transport. The subsequent, Table 31, illustrates specification of CO<sub>2</sub> obtained from EIGA and the specifications for Northern Lights project.

Table 31. Overview of CO<sub>2</sub> specifications from EIGA and Northern Lights.

	EIGA <sup>2</sup>	ISBT <sup>3</sup>	Northern Lights (liquefied CO <sub>2</sub> ) <sup>4</sup> [ppm(mol)]
CO <sub>2</sub> purity	<99%	99.9% v/v min.	
Water (H <sub>2</sub> O)	-	22 ppm v/v max.	≤30
Oxygen (O <sub>2</sub> )	-	30 ppm v/v max.	≤10
Sulphur oxides (SO <sub>x</sub> )	-	0.1 ppm v/v max.	≤10
Sulphur dioxide (SO <sub>2</sub> )	-	1 ppm v/v max.	-
Nitric oxide / Nitrogen dioxide (NO <sub>x</sub> )	-	2.5 ppm v/v max.	≤10
Hydrogen sulphide (H <sub>2</sub> S)	-	0.1 ppm v/v max.	≤9
Carbon monoxide (CO)	<10 vppm	10 ppm v/v max.	≤100
Amine	-	-	≤10
Ammonia (NH <sub>3</sub> )	-	-	≤10
Hydrogen (H <sub>2</sub> )	-	-	≤50
Formaldehyde	-	-	≤20
Acetaldehyde	-	0.2 ppm v/v max.	≤20
Mercury (HG)	-	-	≤0.03
Cadmium (Cd), Thallium (TI)	-	-	Sum ≤ 0.03
Non-volatile Residue (NVR)	-	10 ppm v/v max.	-
Non-volatile Organic Residue (NVOR)	-	5 ppm v/v max.	-
Methanol	-	10 ppm v/v max.	-
Total Volatile Hydrocarbons (THC) as methane	-	50 ppm v/v max. (including 20 ppm v/v max. as total non-me- thane hydrocarbons [TNMHC])	-
Aromatic Hydrocarbon (AHC)	-	20 ppb v/v max.	-
Odor of Solid CO <sub>2</sub> (Snow)	-	No foreign odor	-
Appearance of Solid CO <sub>2</sub> (Snow)	-	No foreign appearance	-
Odor & Taste in Water	-	No foreign odor or taste	-
Appearance in Water	-	No color or turbidity	-

<sup>2</sup> [Doc 126 20 Minimum Specifications for Food Gas Applications \(eiga.eu\)](#)

<sup>3</sup> [WPGSFEP CO<sub>2</sub>-00-EN draft.indd \(parker.com\)](#)

<sup>4</sup> Northern Lights Concept Report 2019

### i.3 Selection of transport form - influence of distance and capacity

Several studies have been conducted with relation to optimisation of transport of large volumes of CO<sub>2</sub> [1-6] in a CCS context. For transport of large volumes (>1 million tonne per annum (MTPA)) only pipeline and ship transport are viable transport options. Road transport is typically only considered for smaller volumes and for short distances when establishing a pipeline is not feasible.

Transport of CO<sub>2</sub> by ship and pipeline have different advantages and disadvantages.

In general, CO<sub>2</sub> transport by ship or pipelines is the most cost-efficient solution for long distance transport of large volumes of CO<sub>2</sub>. Ship is a more flexible option than pipeline. For ships, the transportation route can easily be changed if another CO<sub>2</sub> source or storage site emerge, likewise the capacity of the transportation chain can be gradually upgraded by adding more ships if demands grow. Also ships (if a standard carrier type is selected), can be reused for transportation of other goods e.g., LPG, NH<sub>3</sub>, etc. in case the CO<sub>2</sub> source should cease production. CO<sub>2</sub> transport by ship is on the other hand more costly than pipeline transport for short to medium distances and it requires costly CO<sub>2</sub> terminals with intermediate storage facilities.

For transport of large volumes of CO<sub>2</sub> (and obviously for CO<sub>2</sub> point sources located inland away from waterways) CO<sub>2</sub> pipelines will be the more cost-efficient solution. In a study by ZEP [2] the cost of CO<sub>2</sub> transport for 10 MTPA has been compared between ship and pipeline as shown in Figure 47. With the chosen assumptions e.g., pipeline utilisation factor of 50%, it appears from Figure 47 that pipeline transport is economically favoured for transport distances up to 500-700 km, where after ship transport is the favoured option. It also appears that at very short distances the ship option becomes much more costly. This is related to the fact that the full CAPEX investment for the ship case (ship + terminals) is present even for short distances and that the ship will spend most time in harbour loading and unloading. Different assumptions such as smaller CO<sub>2</sub> transport volumes will however change the turnover point where ship transport becomes more favourable.

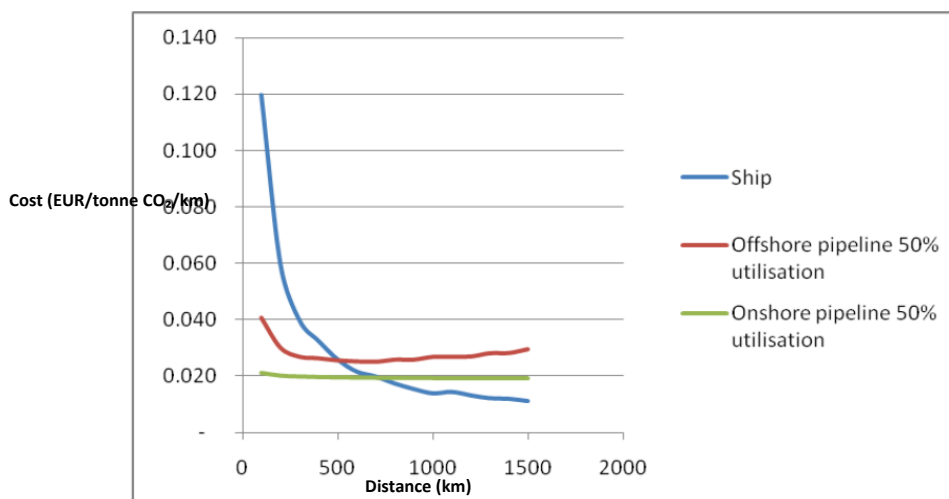

**Figure 47. Cost of CO<sub>2</sub> transport (EUR/tonne/km, 2010 cost level) by pipeline at 50% capacity and by ship at 100% capacity (including terminal) for 10 MTPA. Source: ZEP [2]**

The amount of energy and the associated CO<sub>2</sub> emission required for transporting CO<sub>2</sub> will clearly be dependent on the transport distance but also of the transport form. Pipeline transport will typically be the most energy efficient (less emission intense) mode of transportation and road truck the more emission intense.

In Table 32 an example is shown of the estimated CO<sub>2</sub> emission for 200 km transport of CO<sub>2</sub> by respectively pipeline, ship and truck using energy data from this catalogue. An important message from Table 32 is that

although the CO<sub>2</sub> emission related to transportation varies significantly between the transport forms it constitutes only a small fraction of the transported amount of CO<sub>2</sub> even for a distance of 200 km.

**Table 32 - Example of estimated CO<sub>2</sub> emission associated with transport of CO<sub>2</sub> for 200 km by different transport forms. (Only CO<sub>2</sub> related to the energy (fuel and electricity) requirement for operation is considered. \*Estimated as emission related to electricity consumption for pumping using 135 g CO<sub>2</sub>/kWh (pump is installed at the inlet plant).**

	<i>Pipeline</i>	<i>Ship</i>	<i>Truck</i>
CO <sub>2</sub> emission in % of transported volume	0.05 %*	0.4 %	1.6%

In addition to cost, other factors such as regulation, safety, timeframe, and availability, public perception, etc. could influence the choice of CO<sub>2</sub> transport technology. For instances it may be difficult to establish a CO<sub>2</sub> pipeline through densely populated areas hence road tanker transport may be the preferred solution even though it will lead to increased transportation costs.

#### i.4 CO<sub>2</sub> transport by pipeline

CO<sub>2</sub> can be transported by pipeline at conditions as illustrated in Figure 45.

Currently, the USA and Canada have most experience with transport of large volumes of CO<sub>2</sub> by onshore pipelines, although a few CO<sub>2</sub> pipelines do exist in Europe. Offshore CO<sub>2</sub> pipelines are few, however, and the Norwegian Snøhvit CCS project is the best-known example.

In the Netherlands, a smaller CO<sub>2</sub> gas pipeline network exists to supply CO<sub>2</sub> from gas processing plants to large greenhouses for boosting the growth rates and yields of crops.

Table 33 lists examples of operational CO<sub>2</sub> pipelines with main data incorporated from the North America and Europe.

**Table 33. Examples of operational CO<sub>2</sub> pipelines [5].**

<i>Name</i>	<i>Country</i>	<i>CO<sub>2</sub> capacity (MTPA)</i>	<i>Length (km)</i>	<i>Diameter (mm)</i>
Weyburn	Canada	2.0	330	305-356
Saskpower Boundary Dam	Canada	1.2	66	
OCAP	The Netherlands	0.4	97	
Snøhvit (offshore)	Norway	0.7	153	
Bati Raman	Turkey	1.1	90	
Cortez	USA	24	808	762
Central Basin	USA	27	232	406
Monell	USA	1.6	52	203
Sheep Mountain Operational	USA	11	656	656
Slaughter	USA	2.6	56	305
West Texas	USA	1.9	204	203-305

### i.4.1 Possibility of reusing the existing natural gas network for CO<sub>2</sub> transport

In Denmark there is an existing natural gas (NG) transmission and distribution network as described in chapter 112 Natural Gas Distribution Net of the Technology Catalogue.

In a future fossil-free Denmark, one could speculate the reuse of the NG network - or parts of it - for CO<sub>2</sub> transport.

The NG network is designed for 80 bar operating pressure at the gas transmission lines and 40 bar at the main distribution lines. Secondary distribution lines have a design pressure of below 20 bar. MR (Metering and Reduction) stations maintain the various pressure levels at the distribution net whereas the underground gas storage and interconnections maintain the pressure in the main transmission lines. A map of the NG network is shown in Figure 48.

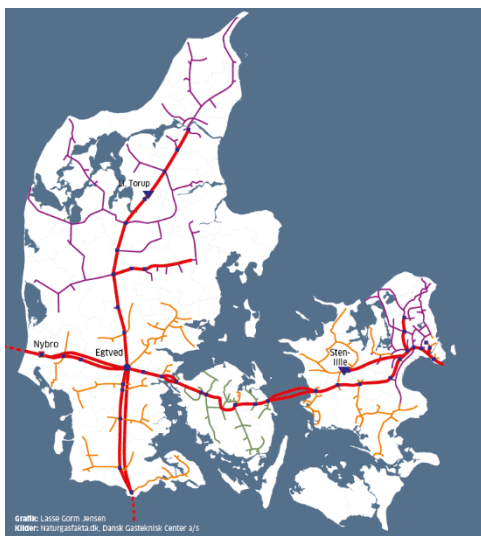

Figure 48. Natural gas pipeline network (steel piping) in Denmark. Source: Naturgasfakta.dk, DGC.

Considering dense phase pipeline transportation of CO<sub>2</sub>, as described in the previous section, where operational pressures are typically in the range of 80-110 bar (above critical pressure) the max operating pressure of the NG system is too low when considering operational margins and pressure drop. The existing NG network is therefore not suitable for dense phase CO<sub>2</sub> transport.

Another possibility is to operate the pipeline network at relatively low CO<sub>2</sub> pressure in the gaseous state. For expected operating temperatures of buried pipeline, i.e. down to 5°C, liquid phase may form at 40 bar. Hence, to stay out of the two-phase region, pressures up to approx. 30 bar could be acceptable. At 30 bar the CO<sub>2</sub> density is reduced to approx. 80 kg/m<sup>3</sup>, greatly decreasing the transportation capacity compared to dense phase 800-1000 kg/m<sup>3</sup> operation. Considering that the pipelines of the NG network is designed for gas transport, the capacity of the main transmission lines are still capable of transporting several MTPA CO<sub>2</sub>, even at 30 bar, which may be sufficient in most scenarios.

The NG pipe network is constructed of carbon steel with small distribution lines of polymer. Carbon steel will be compatible with CO<sub>2</sub> as long as the CO<sub>2</sub> is maintained dry (water content < 30 ppm vol). Any compression and MR station will have to be upgraded to deal with the different physical properties of CO<sub>2</sub>. Thus, from an overall technical perspective, reuse of NG pipelines for CO<sub>2</sub> transport at low pressure conditions (<40 bar) seems feasible although this will need to be evaluated in greater detail.



Other specific stretches of oil and gas pipelines may also become redundant when production from the Danish oil and gas fields in the North Sea is phased out or the general use of oil and gas diminishes. The possible reuse of these for CO<sub>2</sub> transport will have to be evaluated on a case-by-case basis considering remaining lifetime, design pressure and required modifications. Reuse of oil and gas pipelines for CO<sub>2</sub> transport has also been considered in other projects, e.g., the OCAP project in the Netherlands [6].

Alternatively, pipelines can be used for transportation of liquid CO<sub>2</sub> (-30 °C to -10 °C). This, however, will require reheating of the liquefied CO<sub>2</sub> to soil temperature, approx. 5 °C, and operating pressure of 15-35 bara. These operating conditions are needed to avoid freezing of the soil during operation, and evaporation if the temperature increases. In the event of evaporation and generation of gaseous CO<sub>2</sub> from liquid CO<sub>2</sub>, a 530-fold volume increase would occur, resulting in an unacceptable pressure increase.

Taking these factors into consideration, this operation is considered feasible for short pipelines only and needs careful design and operation.

Examples of pipeline transport of super critical CO<sub>2</sub> is limited, and mainly for short distances only, an example being injection into an oil well for “Enhanced Oil Recovery” in the USA. The transport will require pressure >75 barg and temperature >32 °C. The relatively high temperature will not make it possible to transport supercritical phase CO<sub>2</sub> in Denmark. Furthermore, there are still several important safety issues to be resolved for transport in this phase [15].

### i.5 CO<sub>2</sub> transport by ship

Transport of CO<sub>2</sub> by ship is as previously mentioned feasible for medium to long transport distances of medium to large amounts of CO<sub>2</sub>. CO<sub>2</sub> will be transported in liquid state and to some extent refrigerated in order to obtain high transport density and modest pressure level. Transport of CO<sub>2</sub> at high pressure and closer to ambient temperature is also possible but will require a special ship design and is likely to increase the weight of the ship’s pressure tanks relative to cargo. Typically, a CO<sub>2</sub> terminal with interim storage tanks will be required at one or both ends. The required storage capacity will be dependent on the actual operating philosophy and specific design conditions of the transportation chain. The terminals will typically be designed with loading pumps, transfer lines, marine loading arms, metering, and re-liquefaction plant for handling of boil-off gases from storage tanks, etc.

Today no large-scale CCS/CCU project employing ship transport of CO<sub>2</sub> is operational. However, experience exists with ship transport of smaller volumes of liquid CO<sub>2</sub> for industrial consumers around Europe.

- **Experience with CO<sub>2</sub> transport by ship in smaller scale:** The Norwegian fertilizer producer Yara has for more than 20 years operated a small fleet of CO<sub>2</sub> carriers (Yara has today sold-off its CO<sub>2</sub> business, now Nippon gases) between CO<sub>2</sub> recovery facilities (at ammonia plants) and CO<sub>2</sub> terminals around Europe. The ships have been relatively small units as shown in Figure 49 of 1000-1800 t CO<sub>2</sub> cargo capacity. Some of the CO<sub>2</sub> carriers have been converted dry cargo ships. The CO<sub>2</sub> transport conditions have been liquid CO<sub>2</sub> at 15-18 bara and -25 to -30°C. Today, these conditions are sort of a “standard” for transport and supply of industrial grade liquid CO<sub>2</sub>.



Figure 49. M/T Yara Gas III liquid CO<sub>2</sub> carrier. [7]

- **CCS studies involving ship transport of large volumes of CO<sub>2</sub>:** Several studies of CCS projects have considered transport of liquid CO<sub>2</sub> by ship. Ship sizes in the range of 2,000 to 100,000 m<sup>3</sup> CO<sub>2</sub> cargo have been considered [1, 4, 8, 9, 11, 12, 13]. The studies consider different CO<sub>2</sub> transport conditions and ship designs. In many studies custom built CO<sub>2</sub> ships are considered, however it is also widely considered to use a standard gas carrier ship for CO<sub>2</sub> transport. Semi-refrigerated gas carriers used for LPG, ammonia, propylene, and other chemicals have typically operating pressures up to 6-8 bar and operating temperatures down to -50°C. Such vessels may transport liquid CO<sub>2</sub> at 7 bar and -50°C. Standard semi-refrigerated gas carriers are normally not equipped with refrigeration machinery, hence the pressure and temperature of the liquid CO<sub>2</sub> will rise slightly during transport. The former shipping company IM Skaugan (now bankrupt) operated a fleet of semi refrigerated gas carriers in the capacity range of 8-10,000 m<sup>3</sup>, which had been approved for transport of CO<sub>2</sub> [4]. LPG ships may however not be the optimal ship for CO<sub>2</sub> transport because liquid CO<sub>2</sub> has twice the density of LPG implying that the volume capacity may be reduced if transporting CO<sub>2</sub> [9].
- **CCS demonstration project with CO<sub>2</sub> ship transportation:** The CO<sub>2</sub> storage and transportation part of the Norwegian full-scale CCS demonstration project named “Langskip” have studied ship transport of CO<sub>2</sub> from capture plant sites at Oslo and Brevik to a receiving terminal at the Norwegian west coast. Several different ship sizes and classes have been studied [10, 12]. Liquid CO<sub>2</sub> at 15-18 bar and -25-30°C has been selected as the transport conditions in the project i.e., similar to the standard industrial grade. The project has concluded to base the ship design (newbuilt ship) on a concept that closely resembles that of fully pressurised LPG vessels instead of a special design. The 15-18 bar operating pressure is above typical specification of a semi-refrigerated vessels hence the fully pressurized carrier with design pressure of 20 bar is selected. Fully pressurised LPG vessels do normally operate with the cargo at ambient temperature hence does not necessarily have insulated tanks suitable for refrigerated liquid CO<sub>2</sub>. The project reports of about 18 months construction time for such vessels.

### i.6 CO<sub>2</sub> transport by road

Today road transport of liquid CO<sub>2</sub> by tanker truck is common from distribution hubs to industrial consumers. Standard sizes for CO<sub>2</sub> semi-trailers are available from different vendors e.g., ASCO [14]. Trailers with capacities up to 25-30 m<sup>3</sup> liquid CO<sub>2</sub> is typical. CO<sub>2</sub> semi-trailers are pulled by standard trucks as shown in Figure 50.

With tanker truck, liquid CO<sub>2</sub> is transported at 15-18 bar and -25 to -30°C i.e., the industry standard conditions. The density of liquid CO<sub>2</sub> at these conditions is around 1070 kg/m<sup>3</sup>. CO<sub>2</sub> trailer tanks are typically insulated by

PUR foam or vacuum insulated to keep the CO<sub>2</sub> cool during transport. Trucks are typically not equipped with a re-refrigeration unit, hence temperature and pressure of the CO<sub>2</sub> may rise slightly during transport. Truck loading/unloading bays for liquid CO<sub>2</sub> and CO<sub>2</sub> transferring equipment is required at terminals receiving tanker trucks. Standard terminals for truck loading/unloading are commercially available.

Transportable ISO-tank-containers for liquid CO<sub>2</sub> are also available [14].

Considering the above road transport of CO<sub>2</sub> are relatively similar to that of liquid fuels or other pressurised gases.



Figure 50. CO<sub>2</sub> semi-trailer from ASCO. Source; [www.ascoCO2.com](http://www.ascoCO2.com)

### i.7 CO<sub>2</sub> transport by rail

CO<sub>2</sub> transport by rail is technically possible and cryogenic rail cars (see Figure 51) are in use some places in the world today for distribution of liquid CO<sub>2</sub> to industrial users. However, there are no examples where rail cars are used for transportation of large amounts of CO<sub>2</sub> in a CCS value chain. In a Danish context where very few emission sources are linked to the railroad network it is difficult to imagine that rail transportation of CO<sub>2</sub> will ever play a significant role. This option is therefore not described any further in this catalogue.



Figure 51. Railroad car for liquid CO<sub>2</sub> transport. Source: [www.VTG.com](http://www.VTG.com)

### i.8 CO<sub>2</sub> interim storage

Interim storage of CO<sub>2</sub> may be required in connection with CO<sub>2</sub> transportation from source to end destination. This will mainly be relevant when CO<sub>2</sub> is transported in liquid form by truck or ship. The interim storage is needed to buffer the continuous recovery/offtake of CO<sub>2</sub> from capture or utilisation plants between individual truck and ship loads.

As a result, the required capacity for interim storage will largely be governed by the cycle time of the tanker trucks or ships and the desired buffer capacity.

For pipeline transport alone from capture plant to end destination e.g., underground storage, interim storage of CO<sub>2</sub> will typically not be required.

### i.9 Examples of CO<sub>2</sub> transportation chains

To illustrate the different elements of CO<sub>2</sub> transportation and how these can be assembled to create the desired transportation chain a set of examples have been compiled as shown in the following.

#### Example 1 - Transport of CO<sub>2</sub> by road tanker and ship

This example illustrates how CO<sub>2</sub> can be transported from CO<sub>2</sub> source to offshore storage site. For a small to medium size CO<sub>2</sub> emission source located inland, the best CO<sub>2</sub> transport option may be truck transport to a nearby harbour and ship transport to offshore storage or receiving terminal. As an example, this could be a Waste-to-Energy (WtE) plant with 25 t CO<sub>2</sub>/h CO<sub>2</sub> capture or 200,000 tpa. A liquefaction plant is included in the carbon capture facility.

The different elements required for the CO<sub>2</sub> transport chain is as listed below and shown in Figure 52:

- CO<sub>2</sub> interim storage at capture site e.g., 1000 t CO<sub>2</sub>
- CO<sub>2</sub> transport by tanker truck. Capacity 30 t CO<sub>2</sub>/truck indicating 20 truckloads per day
- CO<sub>2</sub> export terminal with interim storage, e.g., 4000 t CO<sub>2</sub> storage
- CO<sub>2</sub> carrier (ship) of 4000 t CO<sub>2</sub> capacity indicating one ship departure every 6 days (cycle time).
- Transfer of CO<sub>2</sub> from ship to injection vessel/platform for underground storage (CO<sub>2</sub> storage is not included in this chapter of the catalogue. The CO<sub>2</sub> carrier may be equipped with facilities for conditioning and injection of CO<sub>2</sub> into a reservoir, but this is not considered here)

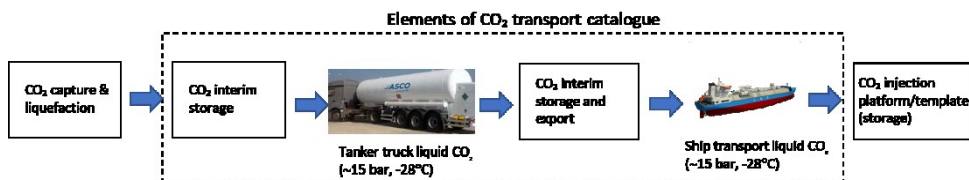

Figure 52. CO<sub>2</sub> transport by road tanker and ship to storage site/import terminal.

#### Example 2 - Transport of CO<sub>2</sub> by pipeline to offshore storage

This example illustrates how CO<sub>2</sub> from a large point source can be transported in pipeline to an offshore storage site. For a large point source say 1 MTPA of CO<sub>2</sub> capture, pipeline transport may be the more attractive solution. In this example it is assumed that CO<sub>2</sub> will have to be transported 50 km in a pipeline onshore before the pipeline goes offshore and proceeds further 30 km to the storage reservoir offshore. The compression plant is included in the carbon capture facility and will deliver CO<sub>2</sub> at the pipeline interface at 150 bar. However, because of the pressure drop in the pipeline say 1 bar/km, and the requirement for high injection pressure, a pumping station for boosting of pressure is included just before the pipeline goes offshore.

In this case, the different elements required for the CO<sub>2</sub> transport chain is as listed below and shown in Figure 53:

- 50 km onshore CO<sub>2</sub> pipeline from capture site to coast. Capacity of 1 MTPA or 120 t CO<sub>2</sub>/h requires an 8" pipeline

- CO<sub>2</sub> pumping station to increase pressure to 150 bar
- 30 km offshore CO<sub>2</sub> pipeline to CO<sub>2</sub> injection template (wellhead)

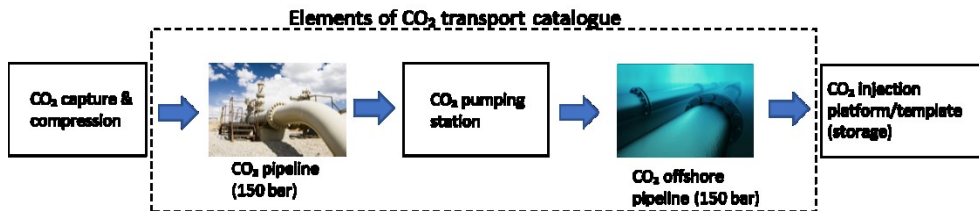

Figure 53. CO<sub>2</sub> transport by onshore and offshore pipeline to storage location.

### Example 3 – Transport of CO<sub>2</sub> by pipeline and ship

In this example CO<sub>2</sub> is transported 20 km from a relatively big capture facility (50 t/h or 400,000 tpa) by pipeline to a CO<sub>2</sub> export terminal where it is liquefied and temporarily stored before transported by ship to end destination. This is relevant in the case the CO<sub>2</sub> source is located at distance from the sea and the conditions are in favour of pipeline transport instead of truck i.e. relatively big CO<sub>2</sub> source. The compression plant included in the carbon capture facility will deliver CO<sub>2</sub> at pipeline interface at 150 bar. The distance to the CO<sub>2</sub> export terminal will not be great enough to require a pumping station on the route.

The different elements required for the CO<sub>2</sub> transport chain is as listed below and shown in Figure 54:

- 50 t CO<sub>2</sub>/h is transported by 30 km onshore pipeline (6 or 8" pipeline)
- CO<sub>2</sub> export terminal with liquefaction plant and interim storage for 5000 t CO<sub>2</sub>.
- CO<sub>2</sub> carrier (ship) of 4000 t CO<sub>2</sub> capacity

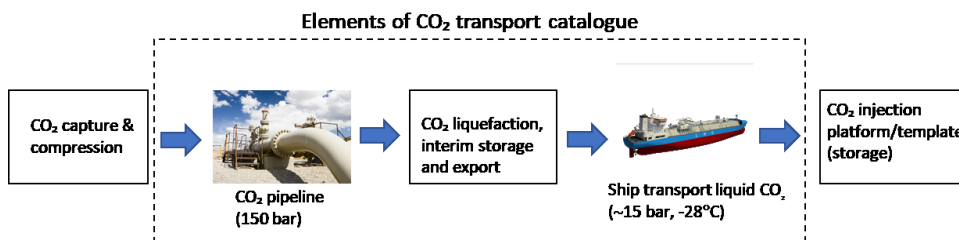

Figure 54. CO<sub>2</sub> transport by pipeline followed by liquefaction interim storage and ship transport.

## i.10 References

- 1 KNOWLEDGE SHARING REPORT – CO<sub>2</sub> Liquid Logistics Shipping Concept (LLSC) Overall Supply Chain Optimization, report 4. VOPOK, Anthony Veder, GCCSI, 21 June 2011.
- 2 The Cost of CO<sub>2</sub> Transport – Post-demonstration CCS in the EU. ZEP report 2010.
- 3 A Review of the CO<sub>2</sub> pipeline Infrastructure in the USA. Presentation by DOE/NETL April 21, 2015. DOE/NETL-2014/1681.

- 4 IPCC Special Report on Carbon Dioxide Capture and Storage. IPCC 2005. Cambridge University Press.
- 5 S. Peletiri, N. Rahmanian, I. M. Mujtaba. CO<sub>2</sub> Pipeline Design: A Review. Energies-11-02184.
- 6 CO<sub>2</sub> Pipeline Infrastructure. IEAGHG, GCCSI report: 2013/18. January 2014.
- 7 Knut Rutlin. Yara presentation. International CCS Conference, Langesund, May 20-21, 2015.
- 8 J. Kjærstad, R. Skagestad, N. H. Eldrup, F. Johnsson. Ship transport—A low cost and low risk CO<sub>2</sub> transport option in the Nordic countries. Int. J. of Greenhouse Gas Control 54 (2016) 168–184.
- 9 Shipping CO<sub>2</sub> - UK cost estimation study. Elementenergy. Final report for Business, Energy & Industrial Strategy Department, Nov 2018.
- 10 Northern Lights Project. Concept report. RE-PM673-00001. 2019-05-21.
- 11 Transportation and unloading of CO<sub>2</sub> by ship. CATO project, WP9 final public report. Dated 2016.04.09.
- 12 Fullskala CO<sub>2</sub> transport med skip. Gassco Concept study, Norwegian full-scale demonstration project. DG3 report dated 06.11.2017
- 13 Knutsen Shipping. The Pressurised CO<sub>2</sub> Transport Solution PCO<sub>2</sub>. Presentation Dansk Industri seminar. Fangst og lagring af CO<sub>2</sub> som klimavirkemidde. 22 September 2020.
- 14 CO<sub>2</sub> tanker Asco: <https://www.ascoCO2.com/>
- 15 CO<sub>2</sub> pipeline infrastructure. IEAGHG / Global CCS Institute. Report: 2013/18, January 2014.

### 411 Liquefaction

#### Contact information

- Contact information: Danish Energy Agency: Emil Esketveit Rasmussen emrm@ens.dk; Christoph Wolter chwo@ens.dk.
- Author: Saeed S. Lafmejani, Zabir A. Rafiq and Ditte F. Jensen from COWI

#### Brief technology description

Liquefaction is used to liquefy CO<sub>2</sub> to enable transport on trucks and ships. In this chapter the focus is on liquefaction of CO<sub>2</sub> captured from biogas plants. Biogas is produced in biomass digesters at biogas plants and consists of 99% methane (CH<sub>4</sub>) and carbon dioxide (CO<sub>2</sub>); 60:40 vol%, respectively. To produce bio-methane, the biogas is upgraded in a biogas upgrading plant to biomethane. Carbon dioxide, hydrogen sulfide (H<sub>2</sub>S), and other impurities are removed in this process. Subsequently, the carbon dioxide is purified in desulfurer columns and activated charcoal beds before the CO<sub>2</sub> can be liquefied and utilized. (Figure 55). [1]

The CO<sub>2</sub> gas from biogas plants needs to be cleaned before liquefaction because it can contain impurities such as water, hydrogen sulfide (H<sub>2</sub>S), volatile organic compounds (VOC), etc., which can have various detrimental effects.

- Moisture present in the CO<sub>2</sub> gas can freeze and cause blockages in the equipment, e.g., plugs formed as a result of gas clathrate formation.
- Hydrogen sulfide (H<sub>2</sub>S) is corrosive and can damage the equipment, leading to increased maintenance needs and potential safety risks. It can also react with other components during compression, affecting the efficiency of the compression process and potentially impacting the quality of the liquefied CO<sub>2</sub>.
- VOCs can corrode equipment, reducing its performance and lifespan. VOCs can also interfere with the cooling and condensation processes, making it harder to efficiently liquefy the CO<sub>2</sub> gas.

As described in Section "CO<sub>2</sub> properties in relation to transport" even minor proportions of impurities in the CO<sub>2</sub> gas can substantially alter its thermodynamic properties, change CO<sub>2</sub> dewpoint and therefore increase energy requirements for compression. Therefore, it is crucial to remove impurities before compression and liquefaction to ensure smooth operations, protect equipment, and produce high-quality liquefied CO<sub>2</sub>.

The cleaned and dried CO<sub>2</sub> can then be liquefied in a liquefaction process. Typical parts of a common liquefaction process are presented in Figure 55. In the shown method, closed loop refrigeration cycle using ammonia (or propane) as cooling fluid is used. This liquefaction process is split into five sections; CO<sub>2</sub> compression train, pre-cooler, drier, the ammonia refrigeration cycle and liquefied CO<sub>2</sub> distillation column.



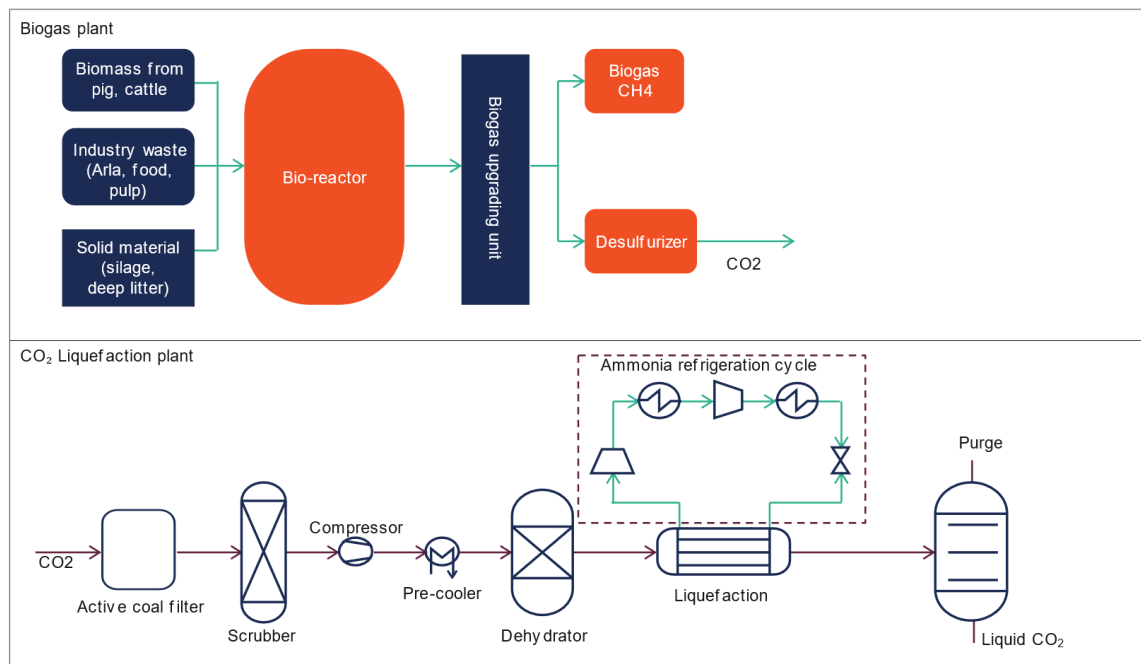

Figure 55 Integrated liquefaction unit coupled with a typical biogas plant.

The cleaned biogenic  $\text{CO}_2$  available at atmospheric pressure and ambient temperatures, enters the  $\text{CO}_2$  compression train, where the  $\text{CO}_2$  is compressed and cooled to achieve a suitable pressure for liquefaction at the outlet. The number of compression stages depends on the desired liquefaction pressure. After each stage of compression, intercoolers cool down the gas and flash separators remove water.

After the compression train, the  $\text{CO}_2$  passes through an impurity removal unit to remove potential impurities if required. The gaseous  $\text{CO}_2$  stream is then cooled to  $25^\circ\text{C}$  in a cooler, and further cooling to the liquid state is then conducted in a shell and tube heat exchanger using an ammonia refrigeration cycle. Upon passing through the liquefaction unit, the  $\text{CO}_2$  stream will change state from gas to liquid and even cooled down slightly to the temperature lower than  $\text{CO}_2$  condensation temperature (sub-cooled) in a separate heat exchanger.

For  $\text{CO}_2$  streams that have remaining impurities, the temperature at which the liquid starts to become gas (bubble point temperature) is significantly lower than in the case of pure  $\text{CO}_2$ . Consequently, the  $\text{CO}_2$  stream may only be partially condensed after it has passed through the condenser. In such scenarios, a flash tank is utilized to remove the uncondensed gases, comprising both impurities and some  $\text{CO}_2$ , as a measure to prevent impurity accumulation in the process. The liquid, which is primarily  $\text{CO}_2$ , is directed through a separator where liquid  $\text{CO}_2$  is isolated and sent for further purification in a  $\text{CO}_2$  distillation column, before being sent to intermediate storage. Subsequently the  $\text{CO}_2$  may then be transported for utilization or storage.

It is important to mention that the refrigeration circuit, which drives the liquefier, is an ammonia-based two-stage vapor compression cycle equipped with an intercooler and a primary heat exchanger (condenser). The ammonia acts solely as a coolant in the liquefier, whereas all other heat exchangers in the process, including the intercoolers of the compression train, the pre-cooler, the intercooler, and the main heat exchanger of the ammonia refrigeration cycle, are cooled by water.



To minimize emissions of CO<sub>2</sub> into the atmosphere, the evaporation of CO<sub>2</sub> needs to be mitigated by appropriate storage and containment conditions, which should be considered as part of the process design.

As described above, closed cycle CO<sub>2</sub> liquefaction involves the use of a separate working fluid (ammonia or propane), often referred to as a refrigerant or a secondary fluid. The CO<sub>2</sub> gas is first compressed, and then heat is transferred to the working fluid to cool the CO<sub>2</sub> gas. The working fluid absorbs the heat and undergoes a phase change, typically from a gas to a liquid or a subcooled liquid. This process allows the CO<sub>2</sub> gas to be indirectly cooled and eventually liquefied. In the following section of this chapter, open cycle liquefaction methods will be described.

### Open cycle liquefaction methods

Open cycle CO<sub>2</sub> liquefaction refers to a process in which the CO<sub>2</sub> gas is directly compressed, cooled, and liquefied without the use of a separate working fluid. In this approach, the CO<sub>2</sub> gas undergoes compression to increase its pressure, followed by cooling to lower its temperature and reach the liquefaction point. The cooling is typically achieved using cooling water or refrigeration systems. Once the gas is cooled sufficiently, it condenses into a liquid state, which can be stored or transported for various applications. Given the high CAPEX of turbo-compressors, open cycle liquefaction becomes economically feasible only for very high CO<sub>2</sub> flow rates, which exceeds the CO<sub>2</sub> production rate from biogas plants. The following two sub-sections describe two open cycle liquefaction methods, one using a valve and the other a turbine.

#### With a valve

The process flow diagram of this design is shown in Figure 56. In this design, the first compressor stage increases the pressure of the captured gas to the transport pressure. After cooling, the gas undergoes several stages of compression, which increases the pressure of the gas to 85 bara. In the cooler of the last compressor stage, the gas is liquefied using cooling water. The liquefied CO<sub>2</sub> is then further cooled by exchanging heat with the cold recycle stream. Subsequently, the high-pressure CO<sub>2</sub> is depressurized to the transport pressure through a valve. The liquid and vapor CO<sub>2</sub> are then separated in a flash column. The vapor CO<sub>2</sub> is recycled while the liquid CO<sub>2</sub> is sent to the CO stripper where CO is removed from the liquid.

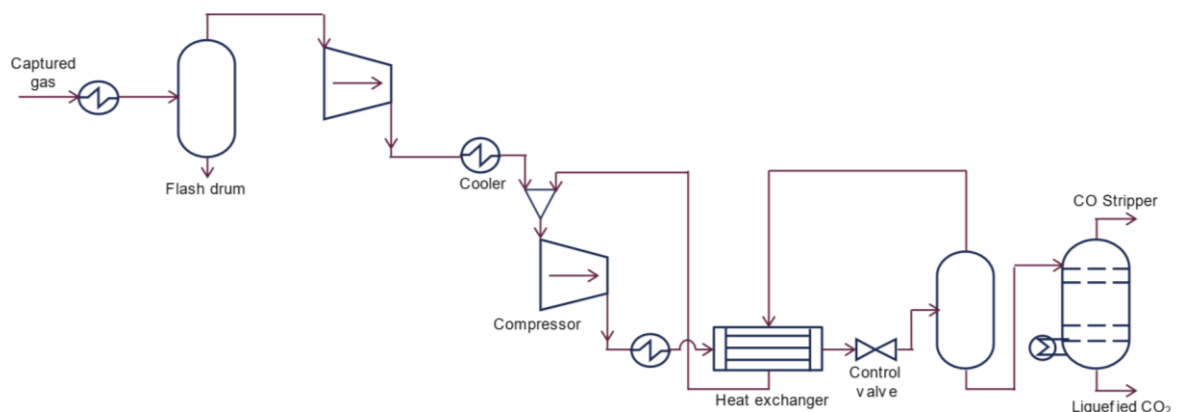

Figure 56. Schematic diagram of an open cycle liquefaction design with a valve.

### With a turbine

In the given design, gas expansion is accomplished using a turbine rather than a compressor, as can be seen in Figure 57. A primary benefit of this approach is the potential for electricity generation as the gas passes through the turbine. A drawback, however, is the necessity for the gas to be in the vapour phase prior to expansion, coupled with a lower liquid split owing to reduced high-end pressure, leading to a larger recycle stream. The costs associated with this design are notably more substantial than those of the open cycle design that employs a valve, due to the increased flow rate of the recycle stream and the additional expenses related to the turbine.

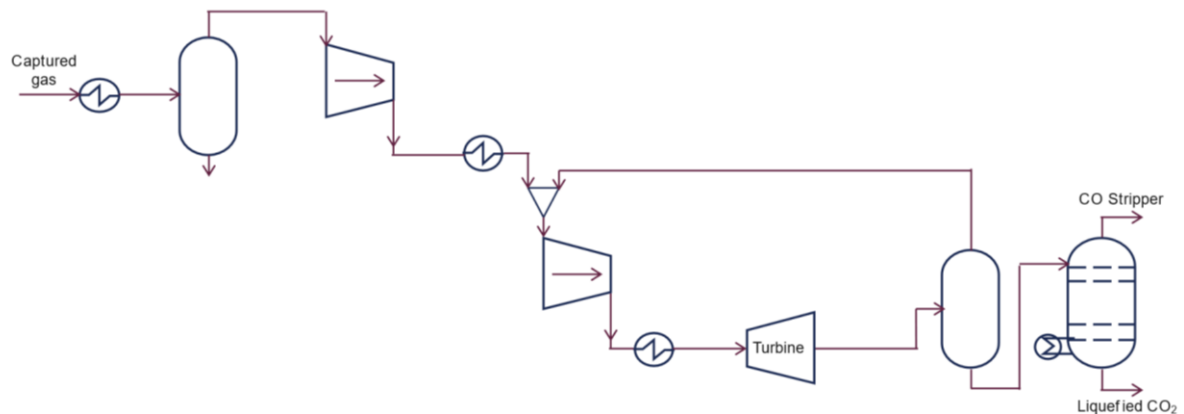

Figure 57. Schematic diagram of an open cycle liquefaction design with a turbine.

### Storage pressure

CO<sub>2</sub> may be liquefied at various temperature and pressure conditions (-56 to 31 °C and pressure of 5.2 to 74 bara). Typical conditions for transport, interim storage, and trading of industrial CO<sub>2</sub> are in the order of -28 °C and 15 bar. In a standard industrial CO<sub>2</sub> liquefaction solution, CO<sub>2</sub> is compressed to 15-20 bar and liquefied by chilling at -25 to -30 °C.

### Standards

A liquefaction plant should be designed after European norms (not limited to):

- Pressure Equipment Directive PED 2014/68/EU
- Machinery Directive 2006/42/EC
- Low Voltage Directive 2014/35/EU
- Cooling Directive 378

### Input

The inputs to a CO<sub>2</sub> liquefaction system include the following [2]:

- **CO<sub>2</sub> Stream:** This is the gaseous CO<sub>2</sub> captured from a power plant, biogas plant or industrial facility. The purity of this stream can vary depending on the capture method and the source of the CO<sub>2</sub>. For example, CO<sub>2</sub> captured from a cement plant or a coal power plant may contain different levels and types of impurities, or CO<sub>2</sub> from biogas plants might contain traces of methane, water vapor, nitrogen, oxygen, hydrogen sulfide or siloxanes, depending on how effectively these have been removed during the biogas upgrading process or CO<sub>2</sub> cleaning system downstream the biogas upgrading unit.

- **Energy:** Energy is required to run the compression and refrigeration cycles that convert the gaseous CO<sub>2</sub> into a liquid. The amount of energy required can depend on factors like the pressure and temperature at which the CO<sub>2</sub> is to be liquefied, and the purity of the CO<sub>2</sub> stream. The energy requirement for a sample plant is outlined in “Energy balance” section of this chapter. The energy consumption per ton of CO<sub>2</sub> is detailed in the “Prediction of performance and costs” section of this chapter.
- **Cooling Medium:** The cooling medium is used in the refrigeration cycle to cool down the CO<sub>2</sub> gas and convert it into a liquid. This could be a refrigerant like ammonia.
- **Water:** Water may be used to cool the equipment in the liquefaction process.
- **Auxiliary Materials and Consumables:** These could include lubricants for the compressors, replacement parts for the equipment, and other consumables required for the operation and maintenance of the liquefaction system.

### Output

The outputs from a CO<sub>2</sub> liquefaction system are as follows:

- **Liquefied CO<sub>2</sub>:** The main product of a CO<sub>2</sub> liquefaction system is liquid CO<sub>2</sub>. The pressure, temperature, and purity of the liquid CO<sub>2</sub> can vary depending on the specific requirements of the transportation or storage system.
- **Purge Gas:** If the CO<sub>2</sub> stream contains impurities that are not soluble in liquid CO<sub>2</sub>, these impurities may be removed as part of a purge gas. The composition of this purge gas can vary depending on the impurities in the original CO<sub>2</sub> stream.
- **Waste Heat:** The process of compressing and liquefying CO<sub>2</sub> generates heat, which is typically removed from the system using cooling water or air. This waste heat could potentially be recovered and used for other purposes, depending on the specific design of the liquefaction system. Values are provided in “Energy balance” and “Prediction of performance and costs” sections of this chapter.
- **Water:** The CO<sub>2</sub> stream contains water, which is typically removed using a knock-out drum after each compressor pre-cooler. A drier is used prior to liquefaction to eliminate any remaining water content and prevent the formation of gas hydrates.
- **Impurities:** Depending on the source of the CO<sub>2</sub> and the specific capture technology used, the CO<sub>2</sub> stream may contain impurities like sulfur compounds, nitrogen, oxygen, argon, hydrocarbons, or trace metals. A significant portion of these impurities is removed in the absorber of the biogas upgrading plant. The remaining impurities, to meet the ISBT specifications which is an international standard specifying quality of CO<sub>2</sub> for usage in the beverage industry, are typically removed during the liquefaction process in active coal filter, scrubbers, and a catalytic oxidiser.

### Energy balance

An energy balance for a CO<sub>2</sub> liquefaction facility, which includes CO<sub>2</sub> compression, pre-cooling, and refrigeration, is illustrated in Figure 58. This facility processes a CO<sub>2</sub> stream from a biogas plant with a production capacity of 4200 Nm<sup>3</sup>/h, which corresponds to 3.3 t/h of CO<sub>2</sub> production. It is assumed that the CO<sub>2</sub> is cleaned and delivered at atmospheric pressure. The energy balance considers the work required for compression, the necessary pre-cooling of CO<sub>2</sub>, and the removal of heat by the refrigerator.

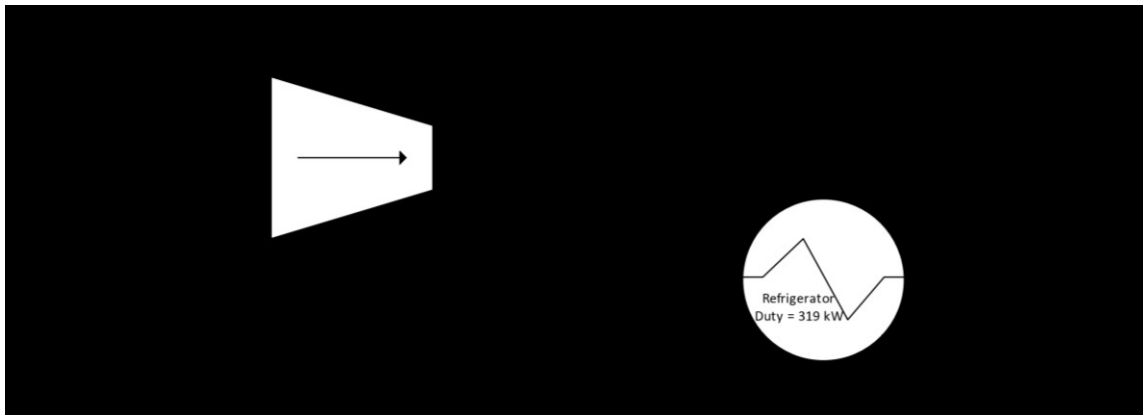

Figure 58: Example of the energy balance for a CO<sub>2</sub> compression and liquefaction plant.

### Application potential

- **Biogas Plants:** Biogas production generates CO<sub>2</sub> as a byproduct. Liquefied CO<sub>2</sub> from biogas plants is a commodity.
- **Fossil Fuel Power Plants:** Coal or natural gas power plants produce large amounts of CO<sub>2</sub> as part of their combustion processes. Liquefying this CO<sub>2</sub> allows for its transportation and storage, contributing to CCS efforts.
- **Industrial Processes:** Various industrial processes such as cement production, steelmaking, and chemical production can generate significant amounts of CO<sub>2</sub>. Implementing CC units and then CO<sub>2</sub> liquefaction in these industries can help reduce their carbon emissions.
- **Oil and Gas Industry:** In addition to the CO<sub>2</sub> produced during combustion in this industry, substantial amounts of CO<sub>2</sub> can be found in natural gas reserves. This CO<sub>2</sub> needs to be separated and can be liquefied for transportation and storage.
- **Ethanol Production:** Ethanol production produces CO<sub>2</sub> as a byproduct. This CO<sub>2</sub> can be captured and liquefied for various uses or for sequestration.
- **Waste Treatment Facilities:** Waste treatment processes, such as waste incineration or wastewater treatment, can produce CO<sub>2</sub> emissions. These can be captured and liquefied for various uses. [3]
- **Hydrogen Production Facilities:** When hydrogen is produced from hydrocarbons, CO<sub>2</sub> is a byproduct. This CO<sub>2</sub> can be captured and liquefied for storage or other uses.

### Typical capacities

The capacities of CO<sub>2</sub> liquefaction plants vary depending on the design and requirements. For a biogas plant in Denmark production of biogas is between 200-6000 Nm<sup>3</sup>/h biogas corresponding to 0.16-4 t/CO<sub>2</sub> h. According to vendor information, the flow of CO<sub>2</sub> should be at least 1 t/h otherwise the liquefaction becomes very expensive compared to output of CO<sub>2</sub>.

For example, Linde Engineering offers modularized units with a single train that can support capacities ranging from 30 (1.25 t/h) to 360 (15 t/h) metric tons per day. Customized solutions or several modular trains can support capacities above this. [4]

### Space requirement

According to vendor information the footprint is 210m<sup>2</sup> and 250 m<sup>2</sup> for respectively 1 t/h and 2 t/h.

### Regulation ability

Some technology providers design their CO<sub>2</sub> plants to start up and shut down within a matter of few hours. Depending on the type of compressors used, the turn down ratio can vary, some vendors claim that it is possible to go as low as 30-40 %. [5]

### Advantages/disadvantages

Below are the advantages and disadvantages of CO<sub>2</sub> liquefaction plants:

#### Advantages:

- **Easier Transportation:** Liquefaction considerably reduces the volume of CO<sub>2</sub>, thus facilitating its transportation via trucks and ships more efficiently.
- **Enhanced Storage:** The density of liquid CO<sub>2</sub> is higher than that of gaseous CO<sub>2</sub>, which allows for more efficient storage in geological formations or other storage sites. [6]
- **Industrial Applications:** Liquid CO<sub>2</sub> is used in various industrial applications, including the food and beverage industry for carbonation, green methanol, and urea production and in enhanced oil recovery techniques to extract more oil from reservoirs.
- **Safety:** In some cases, transporting CO<sub>2</sub> in a liquid form can be safer than transporting it as a pressurized gas, as the pressures required for liquefaction can be lower.

#### Disadvantages:

- **High Energy Consumption:** The process of liquefying CO<sub>2</sub> is energy-intensive, particularly the compression stage. This can result in high operating costs.
- **Capital Costs:** Establishing a CO<sub>2</sub> liquefaction plant requires significant capital investment in equipment such as compressors, cooling systems, and storage tanks.
- **Purity Requirements:** The presence of impurities in the CO<sub>2</sub> stream can complicate the liquefaction process and increase costs. High purity requirements might necessitate additional treatment processes before liquefaction.
- **Environmental Risks:** Although unlikely, there is always a risk of leaks or spills of liquid CO<sub>2</sub> and NH<sub>3</sub>, which could have environmental consequences. For safety reasons NH<sub>3</sub> and CO<sub>2</sub> detectors should be installed at appropriate locations. Simultaneously, the necessary pressure and flow measurement equipment must be installed to promptly detect any potential leakage.

### Environment

The environmental impacts of a CO<sub>2</sub> liquefaction plant can be both positive and negative.

- **CCS:** By liquefying CO<sub>2</sub>, these plants enable the efficient capture and storage of carbon dioxide, which would otherwise be released into the atmosphere. This can be beneficial in reducing greenhouse gas emissions and combating climate change.
- **Energy Consumption:** The CO<sub>2</sub> liquefaction process requires a significant amount of energy, particularly for compression and cooling. If the energy used is derived from fossil fuels, this can offset some of the environmental benefits by contributing to air pollution and greenhouse gas emissions.
- **Chemical Use:** The use of chemicals for cleaning and purifying CO<sub>2</sub> may be required in some cases. The improper handling or disposal of these chemicals can lead to environmental contamination.
- **Potential for Leaks:** Although rare, there is a potential for CO<sub>2</sub> leaks in the storage or transportation process. This could have local environmental impacts, though the larger concern is often for human safety in the event of a significant leak.

- **Economic Diversification:** By providing a source of liquefied CO<sub>2</sub>, these plants can support a range of industries (e.g., food and beverage, medical, manufacturing) that utilize CO<sub>2</sub>. This can lead to economic diversification and potentially more sustainable industrial practices.
- **Support for Renewable Energy:** When integrated with biogas plants, CO<sub>2</sub> liquefaction can enhance the production of renewable natural gas (biomethane), by making it possible to extract value from the CO<sub>2</sub> byproduct stream.

### Research and development perspectives

The CO<sub>2</sub> liquefaction technology has reached a mature stage of development therefore the technology readiness level (TRL) is 9, and it is unlikely that substantial further advancements will be made. This technology has been extensively studied, refined, and implemented in various industries and applications. The fundamental principles and processes involved in CO<sub>2</sub> liquefaction are well understood and have been successfully applied in numerous industrial settings.

Given the maturity of CO<sub>2</sub> liquefaction technology, the focus has shifted towards optimizing existing processes rather than developing entirely new approaches. Efforts are being directed towards improving energy efficiency, reducing operational costs, and enhancing the overall sustainability of CO<sub>2</sub> liquefaction systems. This involves advancements in equipment design, process control strategies, and the integration of renewable energy sources to power the liquefaction process.

### Examples of market standard technology

Some companies, such as Linde Engineering, offer both customized and standardized CO<sub>2</sub> plants designed to maximize cost efficiencies through standardization and modularization while giving flexibility to adapt to variations in feed gas sources, as mentioned in "Typical capacities".

Pentair Union Engineering built the first plant in Denmark to recover CO<sub>2</sub> from anaerobic digestion of mature and organic industrial waste for Strandmøllen in Korskro, the biogas plant is owned by Nature Energy. Furthermore, multiple cleaning steps are used before the liquefaction of the CO<sub>2</sub> so that Strandmølle can fulfil the ISBT and EIGA-standards for CO<sub>2</sub>. Strandmøllen supplies CO<sub>2</sub> for the food industry, health sector, pharmaceutical industry, iron- and mechanical industry. [7]

Outside Denmark, HZI is to supply CO<sub>2</sub> liquefaction plant for CO<sub>2</sub> Energie CCU project in Switzerland. Nesselbach's visionary project upgrades the existing biogas plant to produce liquefied CO<sub>2</sub> for industrial applications. The compact container-based HZI liquefaction plant processes 4,000 ton/a CO<sub>2</sub>.

### Prediction of performance and costs

#### CAPEX

Liquefaction in the chapter's scope involves compression, cooling, drying, and liquefaction of the CO<sub>2</sub> as well as installation costs. There is very little public information available on the capital expenditure (CAPEX) of liquefaction. The provided table includes public data and data obtained through supplier interactions specifically for small-sized plants suitable for biogas applications. A capacity of 2 ton CO<sub>2</sub> per hour is chosen as the most relevant for biogas plants in the Danish context. For smaller plants with 1 ton CO<sub>2</sub> per hour, CAPEX is comparatively high, as there are significant economies of scale effects. Larger biogas plants with capacities of 4 ton CO<sub>2</sub> per hour will also be relevant in the Danish context, and data from suppliers of liquefaction units hints at further savings from economies of scale.

Table 34: Liquefaction CAPEX (2020 level).

Flow ([t LCO <sub>2</sub> ] /h)	CAPEX (MEUR/ [t L /h])	Source
1.8	0.74	[8]
2.0	1.51	[9]
2.0	1.25	[9]
2.0	1 - 2	Dialog with suppliers

### OPEX

Limited information regarding the energy demand for these processes is available in the literature. The following table presents the electricity consumption of the primary consumers, namely compression and liquefaction, along with the relatively smaller consumer, drying. Energy efficiency is assumed to reduce the energy usage slightly until 2050.

Table 35: Electricity consumption of the liquefaction main components.

Parameter	Electricity consumption (kWh/t CO <sub>2</sub> )	Source
Compression	69	[9]
Drying	2	[8]
Liquefaction	64	[8]
Whole liquefaction process	200 - 225	Dialogue with suppliers

Note: Electricity consumption by suppliers includes pumping of liquefied CO<sub>2</sub> into storage tanks and on to trucks.

### Learning curves and technological maturity

The CO<sub>2</sub> liquefaction process has reached a mature stage, indicating a high level of technological maturity. While the CO<sub>2</sub> liquefaction process can still benefit from incremental improvements and cost optimization through learning, the potential for significant breakthroughs or drastic cost reductions is limited at this mature stage. The focus shifts towards refining existing processes, enhancing efficiency, and integrating sustainable practices to further improve the environmental performance and overall efficiency of CO<sub>2</sub> liquefaction.

### Uncertainty

Since the technology is well matured, it has a very limited uncertainty. Suppliers indicate an accuracy of the financial data of +/- 20%. The uncertainty in this catalogue is to a lesser extent attributed to the technological maturity but rather the low number of data points.

### References

- [1] [version 10 - technology data for renewable fuels.pdf \(ens.dk\)](#)
- [2] <https://doi.org/10.1016/j.ijrefrig.2019.04.011>
- [3] Bai, R.L., Jin, L., Sun, S.R., Cheng, Y. and Wei, Y. (2022), Quantification of greenhouse gas emission from wastewater treatment plants. *Greenhouse. Gas. Sci. Technol.*, 12: 587-601.
- [4] [CO<sub>2</sub> purification and liquefaction | Linde Engineering \(linde-engineering.com\)](#)
- [5] Internal COWI Knowledge.
- [6] <https://www.usgs.gov/faqs/whats-difference-between-geologic-and-biologic-carbon-sequestration#:~:text=Geologic%20carbon%20sequestration%20is%20the,rock%20formations%20in%20geologic%20basins>.
- [7] BBA. (2018, May). Utilization of biogas CO<sub>2</sub> adds another level to the circular economy. Pentair. <https://union.dk/media/85800/biogas-and-circular-economy.pdf>

---

[8] Techno economic assessment of CCUS for a biogas facility in Sweden, Evaluating the economic feasibility for three CCUS concepts, TOBIAS JOHANSSON & MARKUS KNUTSSON, 2022

[9] Andersson, J., Tamm, D., & Berg, K. (2021). Bio-CCS från biogasanläggningar. diva2:1602919



### 412 Intermediate storage of CO<sub>2</sub>

#### Contact information

- Danish Energy Agency: Danish Energy Agency: Emil Esketveit Rasmussen emrm@ens.dk; Christoph Wolter chwo@ens.dk.
- Author: Zahir A. Rafiq and Ditte F. Jensen from COWI

#### Brief technology description

Once the captured CO<sub>2</sub> from the biogas upgrading plant has been liquefied and purified, to meet the desired specifications, typically 99.99% pure CO<sub>2</sub>, it is stored in intermediate storage tanks prior to being utilized. The intermediately stored CO<sub>2</sub> can be used in various applications, such as production of e-Methanol or be used in greenhouses for plants.

Storage tanks for intermediate storage of CO<sub>2</sub> can be cylindrical or spherical in shape, both of which are practical options. The cylindrical tanks can be both vertical and horizontal, where the vertical tanks take up less foot-print area. The maximum capacity of cylindrical storage tanks fluctuates based on the pressure selected. Although spherical tanks can contain twice the pressure with the same wall thickness, their construction is more complex and thus seldomly used as they are more costly in smaller capacities than cylindrical tanks. The decision regarding the shape of the tanks should be guided by cost-effectiveness and foot-print area available.

To reduce the amount of boil off gas from the liquefied CO<sub>2</sub> the tanks are typically insulated. The tanks are either insulated with for instance polyurethane or can be vacuum insulated. For tanks isolated with polyurethane additionally a fridge unit is required to keep the CO<sub>2</sub> pressure stable inside the tank. In connection with biogas plants, typically horizontal or vertical polyurethane insulated CO<sub>2</sub> storage tanks are used.

The pressure in each tank is managed by allowing a small portion of the CO<sub>2</sub> to boil-off, the rate of which depends on the surrounding temperature. The boiled-off CO<sub>2</sub> can be sent back for re-liquefaction either locally or send back to the liquefaction part of the plant. Locally at the storage tank the boil off gas can be liquified by an installed refrigeration compressor or the purge gas can be utilized in the process again, see Figure 59.

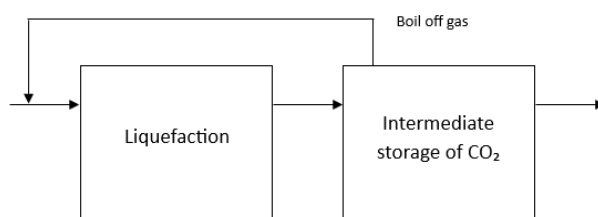

Figure 59. Re-liquefaction of boil off gas.

On the other hand, while transferring the liquid CO<sub>2</sub> to the truck, the pressure within the truck's container must be regulated by releasing evaporated CO<sub>2</sub>, which will subsequently be returned to the storage tanks.



Figure 60. Concept of horizontal storage tanks. Source: Pentair.com

### Tank materials

The material used for the tank varies depending on the pressure and temperature of the stored CO<sub>2</sub>. [1] Forged carbon steel is used for high pressure conditions (45 barg and 10 °C). For medium pressure conditions (15 barg and -29 °C) carbon steel is used with insulation either polyurethane or vacuum. And for low pressure (7 barg and -49 °C) carbon manganese steel, stainless steel and low temperature steel is proposed in literature. For storage of medical quality CO<sub>2</sub> there can be a requirement that the storage tank material shall be stainless steel.

### Input

CO<sub>2</sub> from the liquefaction system is pumped to the intermediate storage tanks, where it is stored prior to being pumped to either a road tanker or to a ship. If the distance from the liquefaction system to the storage tanks is too large, the CO<sub>2</sub> shall be sub-cooled to avoid too much boil off.

The electricity input for pumping the liquefied CO<sub>2</sub> into the storage tanks and onto tanker trucks is negligible and has by some suppliers been added onto the electricity input for liquefaction.

### Output

From the intermediate storage tanks, the CO<sub>2</sub> is transferred to a truck, a rail tanker, a ship tanker/carrier or to bottles by a CO<sub>2</sub> pump filling unit, see Figure 61 consisting of a rack mounted pump, with the necessary equipment and a connection to the intermediate storage tanks.

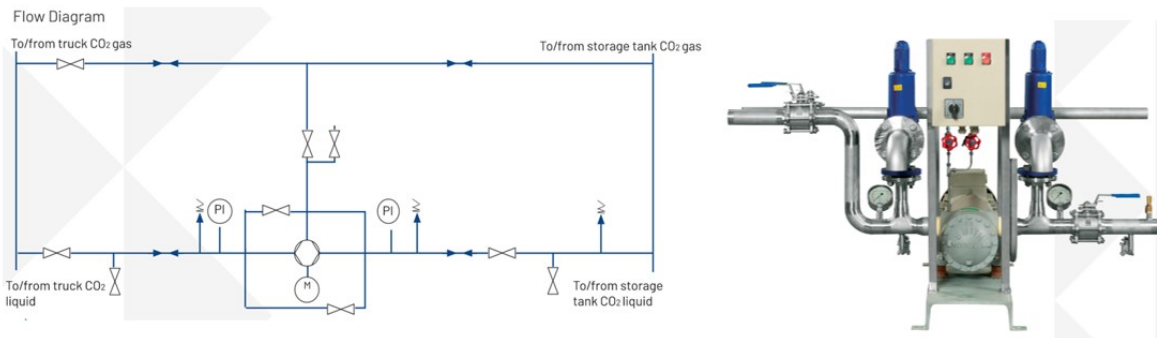

Figure 61. Truck filling unit. Source: [Pentair - CO<sub>2</sub> Truck Filling Unit - TFU - Pentair | Pentair Food & Beverage \[2\]](#)

Typically, the filling unit is combined with a flow meter, and a CO<sub>2</sub> analyzer rack, so the quality and amount of CO<sub>2</sub> is measured to document the final CO<sub>2</sub> quality specifications going to the tankers. The capacity of the CO<sub>2</sub> pump filling unit is defined by the carrier method. Some companies have a standard truck filling unit with a capacity of 20 ton/h. A truck filling unit with a capacity of 20 ton/h, has an installed power of app. 7.5 kW, depending on the manufacture of the units.

**Energy balance**

Boil off gas, due to surrounding heat is led back to the liquefaction system or is purged out to the atmosphere. In some cases, it can be economically feasible to install local refrigeration compressors to re-liquefy the boil off gas and transfer it back to the intermediate storage tanks.

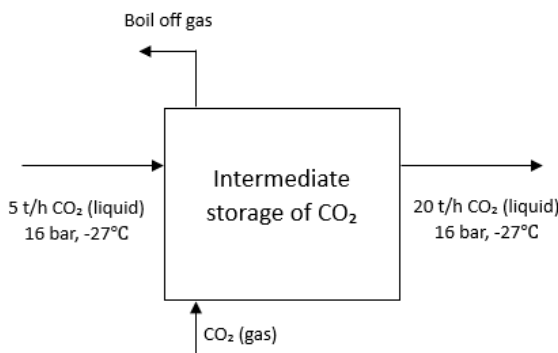

Figure 62. Overview of input and output for intermediate storage of CO<sub>2</sub>.

A stream of evaporated CO<sub>2</sub> is generated when a truck tank is loaded with liquid CO<sub>2</sub>, effectively replacing the evaporated CO<sub>2</sub> in the truck’s tank. This gaseous CO<sub>2</sub> must be re-condensed by directing it back to the liquefaction plant. The volume of this particular CO<sub>2</sub> stream is anticipated to be considerably greater than the amount produced from the temperature-induced evaporation from the tanks.

The proportion of CO<sub>2</sub> that has evaporated in a storage tank can be calculated by comparing the densities of CO<sub>2</sub> in its gaseous and liquid states, under the assumption that the pressure within the tank remains constant.

Table 36. Ratio of tank content filled with gaseous CO<sub>2</sub> vs liquid CO<sub>2</sub>. [1]

	High	Medium	Low	
Pressure	barg	45	15	7

Temperature	°C	10	-29	-49
Density gas	kg/m <sup>3</sup>	135	39	18
Density liquid	kg/m <sup>3</sup>	861	1069	1152
Ratio	%	16	4	2

According to Table 36 the high-pressure scenario, 16% of the CO<sub>2</sub> is projected to return from the truck as evaporated gas, which must be re-liquefied. This re-liquefaction at 45 barg would require approximately 144 kWh per ton on CO<sub>2</sub>, resulting in an increase in power consumption by about 23 kWh per ton of CO<sub>2</sub> transported (16% of 144 kWh/ton CO<sub>2</sub>).

Whereas for the medium-pressure case, 4% of the CO<sub>2</sub> will be expected to need to be re-liquefied, assuming the same power consumption for the liquefaction, it will then be 6 kWh/ton CO<sub>2</sub>. For low-pressure case it will be 2 %, corresponding to 3 kWh/ton CO<sub>2</sub>.

The intermediate storage phase does not generate a substantial demand for power or heat, with the notable exception of the re-liquefaction process, which is significant.

#### Application potential

Intermediate storage is used when CO<sub>2</sub> has been captured and must be stored before being transported by ship or truck or at the receiving end after transportation. The CO<sub>2</sub> is transported in liquid form, and therefore CO<sub>2</sub> is liquefied before it is stored.

Intermediate storage in connection with biogas plants are currently for export of CO<sub>2</sub> for utilization in the food and beverage industry or for industrial use, but subsidies might make CO<sub>2</sub> for storage viable.

#### Typical capacities

Onshore transportation of CO<sub>2</sub> is primarily carried out in trucks. The CO<sub>2</sub> trucks are commonly available and are already in the market by large companies like, Nippon Gasses, Linde, Yara etc. However, it shall be mentioned that the existing CO<sub>2</sub> truck fleet is designed for carrying food grade quality CO<sub>2</sub>.

To transfer the captured CO<sub>2</sub> from the intermediate storage tanks to a truck a CO<sub>2</sub> truck loading station is needed. Companies like Pentair, Airco Process Technologies and other companies within the CC and liquefaction technology can deliver truck filling units at various flow rates. A typical filling capacity is 20 ton/h, but the capacity of the filling unit can easily be increased to a higher rate, in case a rail tanker or a large ship shall be filled with CO<sub>2</sub>.

The capacity of CO<sub>2</sub> transport trucks can either be 20 ton or 30 ton depending on type of truck and if the truck also includes a trailer.

#### Space requirement

The size of the buffer tanks is dependent on the flow of CO<sub>2</sub> from the liquefaction plant as well as the shipping of the CO<sub>2</sub>. [3] As a minimum two storage tanks are recommended if one is out of operation. In normal operation both storage tanks shall be in operation. A minimum storage capacity of 5 days is recommended to make sure that operation is not disturbed due to public holidays, weekends, seasonal variations etc.

Using public data for biogas facilities the flow of CO<sub>2</sub> will be 0.5-5 ton CO<sub>2</sub>/h assuming that all CO<sub>2</sub> from the upgrading of the methane is captured, thus an intermediate storage capacity of 2 x 60 m<sup>3</sup> tanks to 5 x 120 m<sup>3</sup> intermediate storage capacity is needed.

**Regulation ability**

In the storage tank both liquid and gaseous CO<sub>2</sub> will be present. The tank will not be filled 100%, the maximum load of the storage tank varies from 98% for low pressure storage to 72% for high pressure storage, to avoid hydraulic lock. The pressure in the gaseous phase will increase during loading of the tank, the CO<sub>2</sub> vapor is removed as boil of gas. As the tank is unloaded the pressure will drop which can lead to solidification of CO<sub>2</sub>, to avoid this additional CO<sub>2</sub> vapor is added. [1]

The start-up time and shut down time is within half a minute and partial load is also possible if the CO<sub>2</sub> loading pump is frequency controlled, so the speed of the pump can be regulated. However, care must be taken, that the gas return pipeline is seized correctly.

**Environment and safety**

Even though CO<sub>2</sub> is a non-flammable and non-toxic gas, it can cause asphyxiation (by displacing oxygen) when present in high concentrations. Therefore, a significant break in a tank or pipeline could pose a safety risk. As such, safety considerations regarding CO<sub>2</sub> storage and especially when loading a truck must be incorporated into the fundamental design and proper training must be carried of the personal / drivers filling CO<sub>2</sub> to the trucks. A detailed procedure must also be developed to secure safe filling of CO<sub>2</sub> to the CO<sub>2</sub> tankers. Special care must be taken to make sure the pipeline is emptied for liquid CO<sub>2</sub>, before disconnecting the pipelines.

**Research and development perspectives**

As CO<sub>2</sub> intermediate storage in tanks and truck filling units is a matured technology, there are now not much research and development going on in this area. The main development is taking place in the field of underground storage.

**Examples of market standard technology**

Below is an example of intermediate CO<sub>2</sub> storage tank vendors.

**Table 37. Overview of suppliers of intermediate storage tanks for CO<sub>2</sub>.**

Supplier	Gross volume	Norm	Insulation	Design pressure
<b>Pentair</b> [4]	20-110 m <sup>3</sup>	PED 97/23/EC	- Vacuum insulated  - Insulated polyurethane, aluminium cladding  - Polystyrene, vapour barrier, mineral wool, aluminium cladding	20 barg
<b>Chart Ferox</b> [5]	4-67 m <sup>3</sup>	PED2014/68/EU EN 13458	Perlite insulation	25 barg
<b>Airco Process</b> [6]	80 m <sup>3</sup>		Foam insulated	25 barg
<b>ASCO CO<sub>2</sub></b> [7] [8]	6-100 m <sup>3</sup>	PED 2014/68/EU	- High quality vacuum perlite  - Polyurethane insulation covered by aluminium sheet	22 barg

### Prediction of performance and costs

There are limited instances of CO<sub>2</sub> storage at high pressure and ambient temperature conditions. A study conducted by ElementEnergy in the UK has produced a chart that depicts the specific cost of CO<sub>2</sub> storage.

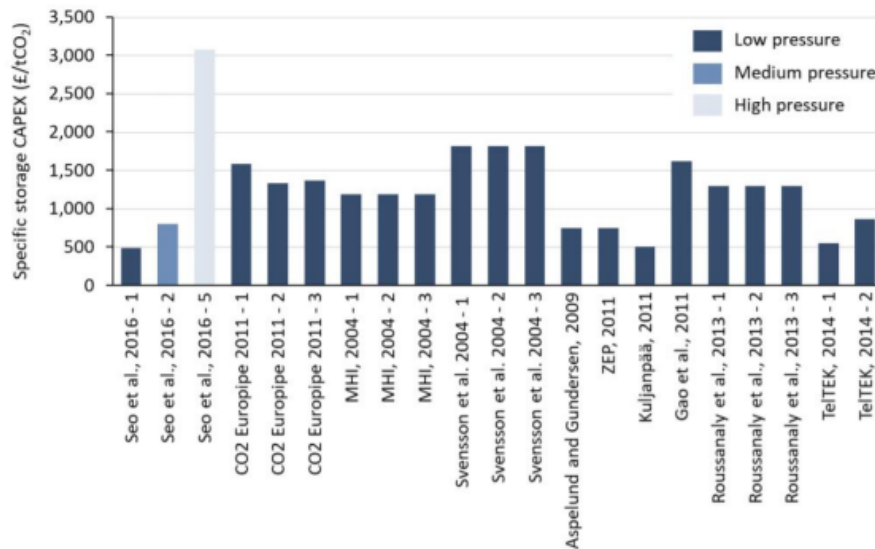

**Figure 63: Literature study on CAPEX prices of CO<sub>2</sub> on-land storage. Source: Element Energy Limited. (2018, November). Shipping CO<sub>2</sub> – UK Cost Estimation Study) [1]**

Only one source is referenced for the high-pressure conditions, and the capital expenditure (CAPEX) cost is notably greater than that of the lower pressure conditions [9]. It should also be mentioned that the typical CO<sub>2</sub> road truck and the CO<sub>2</sub> ship tankers typically has a design pressure of 20-22 barg, corresponding to the medium pressure scenario.

Costs for storage tanks including installation in a Swedish study [9] are around 3,000 EUR per ton storage capacity for large storage tanks of 1,000 to 2,700 ton capacity. Suppliers provide similar figures. Due to economies of scale, costs including installation are around 3,800 EUR per ton storage capacity for storage tanks with a capacity between 20 and 100 ton. Vacuum storage tanks are cheaper than tanks with a PE insulation. Only vertical tanks are considered here, as horizontal tanks tend to be more costly due to the need for more foundation points. As the technology is mature, no cost reductions are assumed in the future.

In addition to the storage tanks there are CAPEX for a truck filling unit. There are no reliable cost estimations in the literature, however, supplier information indicates a cost (installed cost not included) for one truck filling unit of 40 ton CO<sub>2</sub> / h corresponding to around 60,000 to 70,000 EUR in 2020-prices. Installation costs can vary, in the data sheets 20 % of CAPEX is added.

### Learning curves and technology maturity

The technology for CO<sub>2</sub> storage is well-established. The design methods for CO<sub>2</sub> tanks, including risk mitigation measures borrowed from other gases, are also well-understood. Therefore, the overall Technology Readiness Level (TRL) for the CO<sub>2</sub> storage is 9, indicating full maturity.

### Uncertainty

As the technology is mature and data from different suppliers is consistent the uncertainty for CAPEX is +/-20%.

### Reference

- 
- [1] Element Energy Limited. (2018, November). Shipping CO<sub>2</sub> – UK Cost Estimation Study. Elementenergy. [https://assets.publishing.service.gov.uk/government/uploads/system/uploads/attachment\\_data/file/761762/BEIS\\_Shipping\\_CO2.pdf](https://assets.publishing.service.gov.uk/government/uploads/system/uploads/attachment_data/file/761762/BEIS_Shipping_CO2.pdf)
  - [2] Pentair Union Engineering. (s.d.). CO<sub>2</sub> truck filling unit. Pentair. <https://carboncapture.pentair.com/en/solutions/cc-product-CO2-truck-filling-unit-tfu>
  - [3] Vermeulen, T.N.. (2011, 21. juni). CO<sub>2</sub> Liquid Logistics Shipping Concept (LLSC) Overall Supply Chain Optimization: Knowledge Sharing Report 4: . Tebodin Netherlands B.V.. <https://www.globalccsinstitute.com/archive/hub/publications/19011/CO2-liquid-logistics-shipping-concept-llsc-overall-supply-chain-optimization.pdf>
  - [4] [Pentair - Liquid CO<sub>2</sub> Storage Tanks - Pentair - Products | Pentair Food & Beverage](#)
  - [5] [Bulk Storage Tanks | Chart Industries](#)
  - [6] Internal COWI information
  - [7] [Gesamtkatalog\\_04..23.indd \(ascoCO<sub>2</sub>.com\)](#)
  - [8] [Gesamtkatalog\\_4.5\\_1.indd \(ascoCO<sub>2</sub>.com\)](#)
  - [9] Seo, Youngkyun & Huh, Cheol & Lee, Sangick & Chang, Daejun. (2016). Comparison of CO<sub>2</sub> liquefaction pressures for ship-based carbon capture and storage (CCS) chain. International Journal of Greenhouse Gas Control. 52. 1-12. 10.1016/j.ijggc.2016.06.011.

## 421 CO<sub>2</sub> transport in pipelines

### Contact information:

Danish Energy Agency: Emil Esketveit Rasmussen emrm@ens.dk; Christoph Wolter chwo@ens.dk.

Energinet.dk: Rune Duban Grandal

Author: Mogens Zoll Hundahl

### Publication date

2023

### Amendments after publication date

Date	Ref.	Description
-	-	-

### Brief technology description

CO<sub>2</sub> pipelines are relevant for transport of large volumes of CO<sub>2</sub> such as from large point source emitters to storage sites, export terminals or CO<sub>2</sub> utilization facilities.

As described in the introduction to transport, the standard concept for long distance (i.e. >400 km) CO<sub>2</sub> pipeline transport, is dense phase CO<sub>2</sub> transport at the conditions shown in Figure 45.

Dense phase operation is regarded as operating pressures above the critical pressure of CO<sub>2</sub> (73.8 bar). With operational and safety margins, the minimum operating pressure is selected as 80 bar. The maximum operating pressure of CO<sub>2</sub> pipelines is selected as 150 bar. This is a compromise between securing adequate operating range (allowance for pressure drop) and keeping the pipe wall thickness (piping cost) at reasonable level. The density of dense phase CO<sub>2</sub> will only increase weakly with pressure above 150 bar at relevant temperatures (5-20°C) as shown Figure 46, hence there are limited process benefits of operating with higher pressures except from potential longer distances between compression/pumping stations. In addition, it is expected that the permitting process may become increasingly complicated at higher pressures (increased consequence if ruptured), which is also a factor that must be considered.

Very few guidelines and standards exist for CO<sub>2</sub> pipelines. In Europe DNV-RP-J202 and ISO 27913:2016 are relevant.

The initial compression of CO<sub>2</sub> up to 150 bar (depending on choice of transport form) and drying to pipeline specifications are included in the scope of the CO<sub>2</sub> capture plant and explained in the Carbon Capture Catalogue. To achieve pipeline transport, the pressure of the CO<sub>2</sub> must be increased by pump or compressor and the compressor will hence control the pressure at the inlet side of the pipeline. During outages of the compressor isolation valves will isolate the pipeline hence it is maintained as a pressurized line. Isolation valves are also expected along the pipeline (onshore) to enable seal off segments in case of leakages. The allowable distance between isolation valves will depend on a risk assessment of each segment. In populated areas isolation valves are expected to be required more frequently than in rural areas. Typical distances between isolation valves onshore are 10-20 km [16]. Offshore pipelines will typically not have isolation valves between the beach and the wellhead.

For CO<sub>2</sub> pipelines it is not expected that metering stations (for Fiscal metering) will be relevant along the route but will be located together with the compression plant at the inlet or at the end of the pipe. This is of course dependent on the pipeline configuration, i.e. whether it is a pipeline network or point-to-point pipeline.



Pumping/compression stations may be relevant along the route to overcome frictional loss. When transporting in dense phase pressure can be increased by centrifugal or reciprocating pumps which are significantly cheaper than compressors and consume much less energy. A pumping station will be required if the pressure drops below the minimum pipeline operating pressure (80 barg). Typically, this may be every 70-140 km. It is expected that the pumps will be operated in dedicated stations/houses along the route.

For offshore pipelines, compression/pumping stations are not applicable. Therefore, the dimension of the pipeline will have to be selected hence the pressure drop is acceptable without pressure boosting. In general, this implies that the pipeline diameter increases with length of the pipeline for the same transportation capacity [2].

### Comparison of CO<sub>2</sub> conditions for pipeline transport

**Table 38. Comparison of CO<sub>2</sub> conditions for transport by pipeline.**

	Temperature [°C]	Pressure [barg]	Density [kg/m <sup>3</sup> ]	Remark to transport by pipeline
<b>Liquid</b>	-28 to 5	15 to 30	1100	CO <sub>2</sub> needs to be reheated to the temperature of the surrounding soil (minimum 5°C) to prevent freezing of the soil around the pipeline.
<b>Dense</b>	5 to 25	80 to 110	800-1000	Parts of the existing Danish gas transmission pipelines may be used for dense phase CO <sub>2</sub> transport typically in the pressure region of 80 bar, but the future of this option is unknown at present time.
<b>Gas</b>	5 to 25	25 to 35	<1000	Due to the relatively low pressure, gas phase transport can be achieved in the existing Danish gas distribution or transmission pipelines, but this shall be carefully evaluated case by case.
<b>Super critical</b>	>31	>75	<600	Can be used for transport of large amounts of CO <sub>2</sub> , but the behavior of the CO <sub>2</sub> is difficult to predict in the different stages of a pipeline, and hence several safety concerns shall be solved.

#### Liquid phase

As the liquid CO<sub>2</sub> (LCO<sub>2</sub>) is handled at its boiling point, it will easily evaporate due to heating or pressure loss. This condition shall be considered in the design of the pipeline and associated facilities, and facilities shall be protected against overpressure.

Above ground equipment shall be protected against overpressure as heat flux from sun exposure will cause a pressure increase. Blocked-in volumes shall be protected with overpressure protection to prevent ruptures.

The operational window for liquid phase transport is very narrow and needs careful design of the facilities to prevent evaporation due to pressure drop and heating.

Attention shall be paid to pipeline shut down scenarios both scheduled and unscheduled (short and prolonged), and how pressure and temperature settle-out develops. Settle out pressure is best maintained above triple point (i.e. above 5 barg) to avoid generation of dry ice.

The liquid CO<sub>2</sub> phase is not compressible and line packing is not an option. Hence quick shut down reactions are required to prevent rupture and release.

Pipeline transport of liquid phase operation can be achieved with relatively low CAPEX and OPEX reciprocating pumps.

### Dense phase

Small changes in temperature and pressure are less critical for dense phase CO<sub>2</sub> compared to liquid phase CO<sub>2</sub> transport, but requires pressure above the critical pressure (i.e. 73.8 barg), and the temperature shall be kept below critical temperature (i.e. 31 °C). The pressure can be increased above 150 °C depending on the end user specifications and pressure drop in the pipeline, but for practical reasons the pipeline inlet pressure is often chosen to be between 80 - 100 barg, depending on pressure drop and pipeline length. The operation temperature is chosen to be in the 10 – 25 °C range.

Transport of dense phase operation can be achieved with relatively low CAPEX but equally high OPEX reciprocating pumps.

### Gas phase

The gas phase CO<sub>2</sub> is stable if pressure is kept below the critical pressure with operational safety margin. Often maximum operational pressure is set to 30 - 50 barg, depending on the length of pipeline and end of pipeline conditions needed.

Due to the low density, this transport form requires relatively larger pipeline dimensions to transport the same amounts of CO<sub>2</sub> as dense phase, and hence relatively high CAPEX in the pipeline construction and installation is expected. For that reason, this transport form is often used for short distances and relatively low throughput.

Pipeline transport of gas CO<sub>2</sub> can be achieved with both reciprocating and centrifugal compressors. CAPEX and OPEX is higher for compressors than for pumps.

### Super Critical phase

The Super Critical CO<sub>2</sub> (scCO<sub>2</sub>) is a fluid with both liquid and gas phase properties.

Density of scCO<sub>2</sub> varies widely depending on pressure and temperature (see Figure 64).

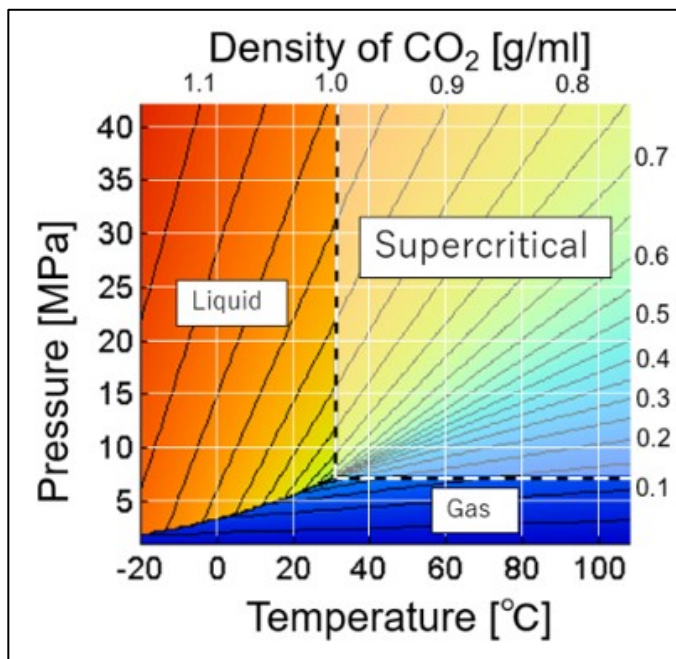

Figure 64. CO<sub>2</sub> density at varying pressure and temperature Image source: ITEC Co., Ltd. Osaka, Japan.

Due to the physical properties, different operational scenarios for pipelines are difficult to predict, and thorough and vigilant design is needed.

Long reach pipelines are not recommended, but short distance pipeline transport can be achieved i.e. from injection compressor/pump to the well head at an injection site. The facilities for handling of sCO<sub>2</sub> shall be carefully designed to accommodate changes to the physical properties during operation.

Transport of sCO<sub>2</sub> can be achieved with both reciprocating and centrifugal pumps/compressors. CAPEX and OPEX is higher for compressors than for pumps.

For comparison, a few scenarios for pipeline transport are listed in Table 39. From the table it is seen that it is only possible to achieve 1/3 of the flowrate in gas phase for the same pipeline size as dense CO<sub>2</sub>.

Table 39. Comparison of scenarios for pipeline transport.

Phase	Flow rate – t/h	Dimension – Inch
Gas	10	6"
Dense	30	6"
Dense	80	8"
Dense	120	10"

### Efficiency and losses

Energy loss from CO<sub>2</sub> pipeline transportation occurs as a result of fluid frictional loss (pressure drop) in the pipelines. The energy loss for CO<sub>2</sub> pipeline transport is a strong function of fluid velocity (approximately third

power), therefore the extent of energy loss will be determined by the design velocity of the pipeline. This is ultimately a trade-off between capital cost (pipeline diameter) and operating cost (pumping energy).

For the technology catalogue CO<sub>2</sub> fluid velocities of 1-2 m/s have been applied for the pipelines resulting in a pressure drop of approx. 0.5-1.5 bar/km. The highest pressure drop (1.5 bar/km) is tolerated for the smaller pipeline diameters (10-30 t CO<sub>2</sub>/h) because it is anticipated that the small bore (< 6") pipeline is used for relative short distances transport of liquid CO<sub>2</sub>.

For gas pipelines CO<sub>2</sub> fluid velocities up to 6 m/s can be accepted.

### Application potential

Pipelines will be applicable for point-to-point transport of CO<sub>2</sub> e.g. from a capture site to an offtake-, storage- or utilization site, or as part of a larger pipeline network or CO<sub>2</sub> hub.

### Typical capacities

The existing CO<sub>2</sub> international pipelines in operation cover a large capacity range; 0.06–27 MTPA. Pipeline diameters from 4" to 30" have been deployed in the USA and Canada.

In a Danish context, CO<sub>2</sub> pipeline transport is not likely to exceed around 0.5-10 MTPA as this will cover many of the largest point sources of CO<sub>2</sub>. The smallest capacity that will be relevant for pipeline transport will of course depend on a lot of factors, such as the distance and location. Since the engineering and installation costs do not scale down proportionally for small bore pipelines, however, it is expected that truck transport will be favored over pipeline transport at low capacities (e.g. below about 50-100 kton CO<sub>2</sub> per year). For very short distances, e.g. a few km's, above ground (rural) terrain pipeline transport could still be an attractive solution, even for small volumes.

### Advantages/disadvantages

The main advantages with pipelines are that large volumes can be transported at low operating costs, with low energy consumption (and CO<sub>2</sub> emission), no occupation of existing infrastructure (roads, harbors, etc.) as well as continuous operation independent on weather conditions and other external disruptions.

Disadvantages with pipeline transport are high investment cost, long planning and construction time, extensive approval procedures i.e. construction within city limits is difficult, land purchase issues, public perception and low flexibility (end-use value) if CO<sub>2</sub> source disappears or is relocated.

### Environmental and safety

#### Environment

The construction phase of a pipeline may have substantial environmental impact depending on the chosen route. An environmental impact assessment (EIA) will be required. It is likely that future CO<sub>2</sub> pipelines will be constructed as part of an integrated CCS or CCU project, hence the environmental impact assessment will cover the entire project.

Once the pipeline is constructed it will only have marginal environmental impact. CO<sub>2</sub> losses from pipeline will not occur during ordinary operation. Blow down of pipeline sections for maintenance or repair work is likely in the operational phase. As long as the blow down rate is slow and controlled it will not have significant environmental impact.

### Safety

CO<sub>2</sub> is a non-flammable, asphyxiant gas which becomes harmful at high concentrations. Safety must be an integral part of a pipeline project from design to operational phase. Risk assessment of exposure of people to CO<sub>2</sub> from accidental leakages must be performed and suitable risk mitigating measures need to be implemented. This may include proper leak detection systems (monitoring for sudden pressure drop), CO<sub>2</sub> sensors at relevant locations and low points, sectionalization (isolation valves) or ESD valves to limit accidental releases, automatic monitoring and shutdown functions.

If a high-pressure CO<sub>2</sub> pipeline rapidly depressurizes to atmospheric pressure, CO<sub>2</sub> will form a mixture of solid and gaseous CO<sub>2</sub> at -78°C. This may create a cloud of heavy CO<sub>2</sub> gas (pancake) which will flow to low points in the terrain. Depending on weather conditions and local obstacles generating turbulence a CO<sub>2</sub> cloud may disperse quickly or be present for several minutes. A risk assessment concerning exposure of third party in the event of rupture will have to be performed as part of the engineering phase. For a CO<sub>2</sub> pipeline there will be operational risks related to the CO<sub>2</sub> phase behavior and load fluctuations, e.g., liquid phase or dry ice formation during sudden drops in pressure (below 5 bara), freezing of safety valves, etc. Maintenance stops with full depressurization will have to be conducted at a slow pace to prevent freezing.

The safety of natural gas pipelines and related installations will be evaluated by the Working Environment Authority in Denmark. It is not precisely known which authority that will evaluate future CO<sub>2</sub> pipelines and what the safety requirements will be.

### Monitoring

In daily operation flow, pressure and temperature of CO<sub>2</sub> pipelines must be continuously monitored. The readings from field instruments shall be transferred to a manned control room.

Buried pipelines are also normally equipped with a cathodic protection system for monitoring of external corrosion. The pipeline will also be equipped with provisions for pig launchers and receivers (a cleaning and inspection device) hence intelligent pigging can be performed for inspection and assessment of internal corrosion and fouling. Since only clean, dry CO<sub>2</sub> gas will be transported in the pipelines, fouling and internal cleaning will probably be less significant compared to the natural gas pipelines.

CO<sub>2</sub> compression/pumping houses, metering house, valve pits or other places where leaking CO<sub>2</sub> can accumulate to dangerous concentrations shall be equipped with CO<sub>2</sub> detectors and alarms.

Flow in and out of the pipelines are to be determined by fiscal metering hence adequate control exist on volumes transferred between different parties (e.g. emission source owner and transport/storage provider). Monitoring of the CO<sub>2</sub> quality, e.g., moisture content, O<sub>2</sub> content and other trace impurities will probably be a requirement at the inlet, hence it is ensured that the CO<sub>2</sub> quality is compatible with pipeline design materials and downstream specifications.

### Research and development perspectives

Pipeline transport of CO<sub>2</sub> and other pressurized fluids is a mature and commercially available technology (TRL 9). Little technical development potential for pipeline transport is expected.

### Prediction of performance and costs

#### CAPEX

For onshore pipelines, COWI has made its own estimate of the investment cost based on inhouse experience obtained from engineering, procurement and installation of natural gas transmission lines in Denmark, taking into account expected cost differences related to CO<sub>2</sub> specific design conditions, e.g., higher pressure, safety factor, etc., where the estimate is benchmarked against references from the literature.

The following assumptions are applied for estimate of CO<sub>2</sub> pipeline investment cost:

- Point-to-point pipeline (no pumps/compressors, valve stations or conditioning equipment included)
- Pipe dimensioned for 120 bar using a safety factor of 0.5 (conservative). Pipeline construction material is carbon steel (extra strong) with polymer coating. Cathodic protection is included.
- For the Danish context unit costs are based on pipeline distance of 50-100 km in rural area. For very short pipelines the unit cost will increase. This effect is not captured in the estimates.
- Liquid and dense phase pipelines are dimensioned for pressure drop of 0.5 to 1.5 bar/km where the highest pressure drop is accepted for the smallest diameter. The corresponding pipeline flow velocities are in the range of 1.2-2 m/s.
- Gas pipelines are dimensioned for 6 m/s flow velocity.
- 3 different pipeline dimensions namely 6, 8 and 10" are priced and used as cost basis for the 3 capacity intervals provided in the data sheet:
  - The 6" pipeline representing gas phase CO<sub>2</sub> flow capacity of 10 t CO<sub>2</sub>/h and the specified unit cost in the data sheet (15 EUR/[t CO<sub>2</sub>/h]/m) is related to a flow rate of 20 t CO<sub>2</sub>/h.
  - The 6", 8" and 10" pipeline representing dense phase CO<sub>2</sub> flow capacity of 30, 80 and 120 t CO<sub>2</sub>/h and the specified unit cost in the data sheet (15 EUR/[t CO<sub>2</sub>/h]/m) is related to a flow rate of 20 t CO<sub>2</sub>/h.
- Sectionalisation valves (ESD) with ancillaries every 15 km is assumed. This is uncertain as regulative requirements for CO<sub>2</sub> pipelines in DK is unclear.
- Installation cost includes trenching and 8 % for controlled drilling, permitting and environmental assessment.
- Cost factor for "Right Off Way", engineering and follow-up added (6 to 10% depending on pipeline size).

For offshore pipeline, the CAPEX is based on ZEP-s estimate [2] for 180 km 12" pipeline transporting 2.5 MTPA CO<sub>2</sub> (approx. 300 t CO<sub>2</sub>/h) but reduced from 4.7 to 4.0 EUR/[t CO<sub>2</sub>]/m to be more in line with expectations for Danish conditions and the estimate for onshore pipeline.

### OPEX

The O&M value is based on ZEP value of 6000 EUR/km for 12" onshore pipeline transporting 2.5 MTPA CO<sub>2</sub> [2]. This corresponds to approx. 20 EUR/km/[t CO<sub>2</sub>/h]. The estimate excludes maintenance and energy cost for the initial CO<sub>2</sub> compression as this is included with the capture plant. The cost is assumed to be fixed O&M cost independent on capacity factor. The variable O&M cost is assumed to be negligible.

### Levelized cost of CO<sub>2</sub> pipeline transport

In IPCC's carbon capture and storage report from 2005 [4] CO<sub>2</sub> transportation costs have been assessed for onshore and offshore pipelines (and ship) as shown in Figure 65.

From Figure 65 (left) the cost of transport of 2.5 MTPA for 250 km can be read to about 4 USD/t CO<sub>2</sub> (2005 cost level), which is close to 4 EUR/t CO<sub>2</sub> in 2020 level (20% escalation and 1.24 USD/EUR). The estimated value for Danish conditions used is 5.3 EUR/t CO<sub>2</sub>, which is higher but in the same order of magnitude as the ICCP value.

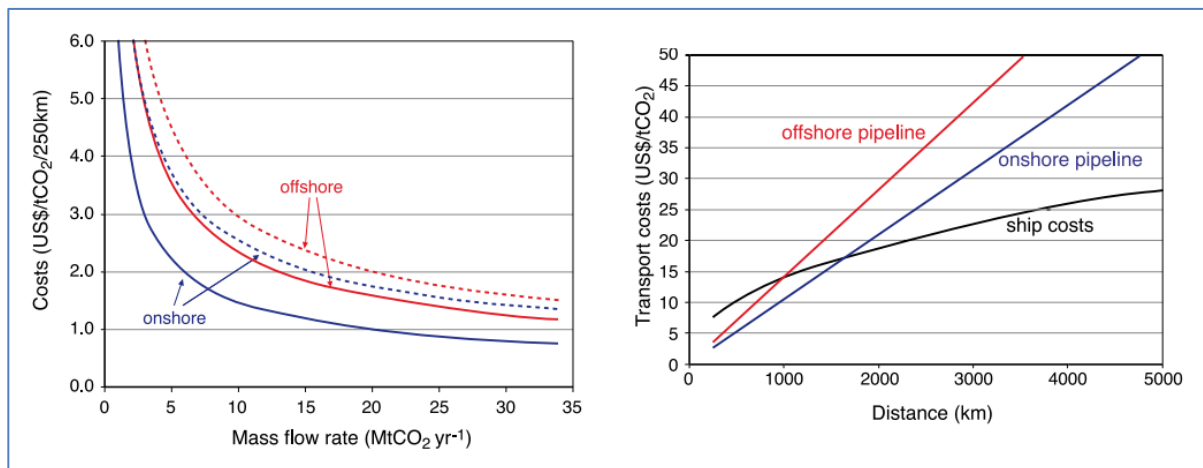

Figure 65 - Transport costs for pipelines (Figures 4.5 and 4.6 from the IPCC report)

In the ZEP report [2], the levelized cost of CO<sub>2</sub> transport for 180 km onshore pipeline is estimated to 5.38 EUR/t CO<sub>2</sub> using different CAPEX annualization parameters (8%, 40 years). With similar CAPEX parameters the estimated cost for Danish conditions will increase to 6.7 EUR/t CO<sub>2</sub>.

### Uncertainty

No CO<sub>2</sub> pipelines have been constructed in Denmark hence there will be uncertainty related to the permitting process and safety requirements. It is likely, however, that the procedures and rules will be relatively similar to what is known for NG pipelines. The uncertainty on specific safety requirements will add some uncertainty to the cost estimates.

### Quantitative description

See separate Excel file for Data sheet

### References

- 1 KNOWLEDGE SHARING REPORT – CO<sub>2</sub> Liquid Logistics Shipping Concept (LLSC) Overall Supply Chain Optimization, report 4. VOPOK, Anthony Veder, GCCSI, 21 June 2011.
- 2 The Cost of CO<sub>2</sub> Transport – Post-demonstration CCS in the EU. ZEP report 2010.
- 3 A Review of the CO<sub>2</sub> pipeline Infrastructure in the USA. Presentation by DOE/NETL April 21, 2015. DOE/NETL-2014/1681.

- 4 IPCC Special Report on Carbon Dioxide Capture and Storage. IPCC 2005. Cambridge University Press.
- 5 S. Peletiri, N. Rahmanian, I. M. Mujtaba. CO<sub>2</sub> Pipeline Design: A Review. Energies-11-02184.
- 6 CO<sub>2</sub> Pipeline Infrastructure. IEAGHG, GCCSI report: 2013/18. January 2014.
- 7 Knut Rutlin. Yara presentation. International CCS Conference, Langesund, May 20-21, 2015.
- 8 J. Kjærstad, R. Skagestad, N. H. Eldrup, F. Johnsson. Ship transport—A low cost and low risk CO<sub>2</sub> transport option in the Nordic countries. Int. J. of Greenhouse Gas Control 54 (2016) 168–184.
- 9 Shipping CO<sub>2</sub> - UK cost estimation study. Elementenergy. Final report for Business, Energy & Industrial Strategy Department, Nov 2018.
- 10 Northern Lights Project. Concept report. RE-PM673-00001. 2019-05-21.
- 11 Transportation and unloading of CO<sub>2</sub> by ship. CATO project, WP9 final publicreport. Dated 2016.04.09.
- 12 Fullskala CO<sub>2</sub> transport med skip. Gassco Concept study, Norwegian full-scale demonstration project. DG3 report dated 06.11.2017
- 13 Knutsen Shipping. The Pressurised CO<sub>2</sub> Transport Solution PCO<sub>2</sub>. Presentation Dansk Industri seminar. Fangst og lagring af CO<sub>2</sub> som klimavirkemidde. 22 September 2020.
- 14 CO<sub>2</sub> tanker Asco: <https://www.ascoCO2.com/>
- 15 CO<sub>2</sub> pipeline infrastructure. IEAGHG / Global CCS Institute. Report: 2013/18, January 2014.
- 16 I. Lawrence. GLOBAL COSTS OF CARBON CAPTURE AND STORAGE. Global CCS Institute. Cost update re-port, June 2017



### 422 CO<sub>2</sub> transport by ship

#### Contact information:

Danish Energy Agency: Laust Riemann, [lri@ens.dk](mailto:lri@ens.dk)

Energinet.dk: Rune Duban Grandal

Author: Jacob Knudsen

#### Publication date

November 2020

#### Amendments after publication date

Date	Ref.	Description
-	-	-

#### Brief technology description

Ship transport of CO<sub>2</sub> is most relevant for transport of medium to large volumes of CO<sub>2</sub> over medium to long distances e.g. from large point source emitters to offshore storage destination or land-based terminals. Ships do however also have the flexibility to operate in a route network picking up CO<sub>2</sub> from multiple locations. In this case ship may be relevant for relatively short transport distances.

As described in the introduction, only limited volumes of CO<sub>2</sub> is transported by ship today and in relatively small ships 1000 – 2000 m<sup>3</sup>.

For ship transport only liquid CO<sub>2</sub> is considered. Most studies in the literature considers modest pressure levels (<20 bar) as this will ensure high CO<sub>2</sub> density without requiring too heavy pressure tanks. However, examples of higher pressure alternatives have also been considered [12, 13]. Thus, the transportation conditions can be grouped in the following three alternatives:

- Low pressure conditions: Around a few bar above the triple point (5.2 bara, -56°C) say 6-8 bara and approx. -50°C. These conditions will result in the highest CO<sub>2</sub> density 1150 kg/m<sup>3</sup> and lowest thickness of pressure tanks. The low temperature will however require more comprehensive (expensive) insulation and use of low-temperature steel types.
- Medium pressure conditions: 15-18 bara and -25 to -30°C (The most common conditions for transport of liquid CO<sub>2</sub> today). This is a CO<sub>2</sub> density around 1070 kg/m<sup>3</sup>.
- High pressure conditions: 40-50 bara and +5 to +15°C. CO<sub>2</sub> density of 800-900 kg/m<sup>3</sup>. This alternative will require pressure vessels with higher design pressure (heavier per volume CO<sub>2</sub>) but less insulation is needed.

The ship design will be different for the different transport conditions. The selection of CO<sub>2</sub> transport conditions will also affect the export terminal design and the CO<sub>2</sub> liquefaction plant to some extent. Examples of design and pressure tank layout of CO<sub>2</sub> carrier ships are shown in Figure 66.

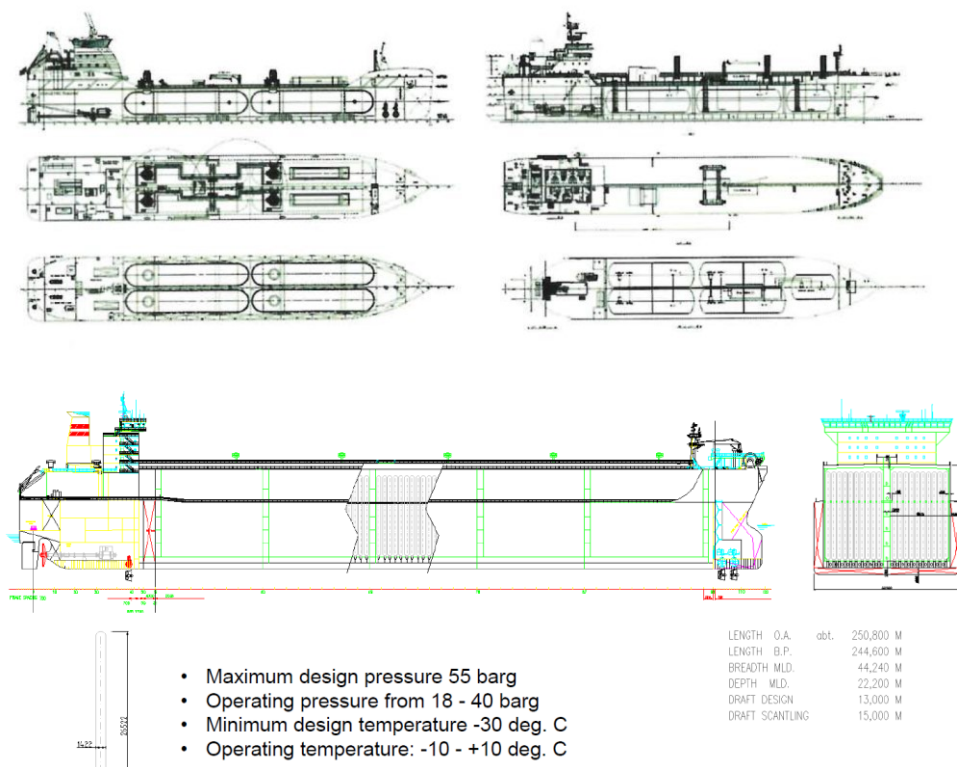

Figure 66. Top) Sketch of refrigerated CO<sub>2</sub> ship designs for Gassco Concept study [12]. Bottom) sketch of Knutsen Shipping's design of a pressurised CO<sub>2</sub> carrier (PCO<sub>2</sub>) [13].

For ship transport the logistics is important to consider as the cost of additional ships is significant. An optimisation exercise should be conducted where transport distance, ship size, unloading/loading time, cruising speed and number of ships are considered. An example of typical values applied to estimate cycle time is shown in Table 40.

Table 40. Example of estimating ship cycle time and number of cycles/year for 700 km (each way) CO<sub>2</sub> transport.

Activity	Duration	Comment
Time for ship loading and unloading	2 x 12 hours	If offshore direct injection to storage,
Time spent cruising:	2 x 700 km/(28 km/h) = 50 hours	28 km/h speed is used
Cycle time	74 hours	
Availability	90%	Impact of weather, repair, maintenance
Total cycles / year	106	

Table 41 provides an example on how much CO<sub>2</sub> that can be transported with one ship per year under the specified assumptions.

Table 41. Example on annually transported CO<sub>2</sub> amount by one ship. Assumptions Cycle time is 4 days (~700 km each way) and availability is 90%.

Ship capacity	2,000 tons	4,000 tons	10,000 tons
CO <sub>2</sub> transported annually	160.000 TPA	330.000 TPA	820.000 TPA

### CO<sub>2</sub> Liquefaction and terminal

To condition CO<sub>2</sub> for ship transport it will have to be liquefied. Liquefaction of CO<sub>2</sub> directly from a CO<sub>2</sub> capture plant (at low CO<sub>2</sub> feed pressure) is described in the Technology Catalogue on carbon capture.

Alternatively, if the CO<sub>2</sub> liquefaction plant is fed by dry high-pressure CO<sub>2</sub> from a pipeline the liquefaction process will be less complicated and consume significantly (approx. 1/3) less energy compared to directly from a capture plant. This can be relevant in the case CO<sub>2</sub> is transported in onshore pipeline to a CO<sub>2</sub> export terminal. In this case one can assume the liquefaction plant investment cost is only 0.2 M€/[ton CO<sub>2</sub>/h] and power use is 50 kWh/ton CO<sub>2</sub>.

The CO<sub>2</sub> terminal will consist of well-insulated storage tanks for liquid CO<sub>2</sub>. The capacity can as a first estimate be selected as 100% of the ship's capacity. The storage tanks will as a minimum need to hold a volume equivalent to the amount of CO<sub>2</sub> recovered between each ship arrival (cycle time). The requirement of buffer e.g. for delays in ship arrival frequency, will normally be desirable. The buffer requirement will have to be evaluated from project to project.

In addition, a terminal will be equipped with transfer lines (liquid CO<sub>2</sub> and vapor return) and pumps that can load/unload the ship in typically around 10 hours will be present. Also, marine loading arms or flexible hoses to connect to the ship and other utilities are required. Vapour equalisation between onshore tank and ship tanks is required during ship loading/unloading. Because of heat ingress into the refrigerated liquid CO<sub>2</sub> storage there will be continuous evaporation of CO<sub>2</sub>. This needs to be re-liquefied at the terminal. In case the terminal is located together with the capture plant, the CO<sub>2</sub> vapours can be routed back to the main liquefaction plant and re-liquefied. If it is a satellite terminal it will need to be equipped with own refrigeration plant unless the ship arrival frequency is high.

### Input

Input to CO<sub>2</sub> ship transport is except for the liquid CO<sub>2</sub> cargo, fuel for propulsion. The fuel consumption is provided in units of MWh/day referring to energy content in the applied fuel (LHV, lower heating value). The fuel consumption applies only when the ship is operating at cruising speed and is an average of loaded and unloaded cruising. The energy consumption during unloading/loading at pier is significantly lower (around 10%) and may in some cases be covered by electric power from land. The consumption during unloading/loading is neglected here.

The fuel consumption applied in the datasheet for the 4,000 and 10,000 ton CO<sub>2</sub> ship of 90 and 180 kWh/day is based on input from Knutsen Shipping.

### Output

Output is liquid CO<sub>2</sub> cargo.

When a CO<sub>2</sub> tanker ship is loaded with CO<sub>2</sub> from an onshore storage tank, the CO<sub>2</sub> vapours in the ship's tank will be returned to the onshore storage tank. This will reduce the effective transport volume (or mass) of the ship. Because of the difference in vapour and liquid density this will only result in 3-4% reduction.

### Efficiency and losses

Significant energy consumption is involved with ship transport. IEA has estimated that 2.5% of the transported CO<sub>2</sub> is emitted from transporting CO<sub>2</sub> by ship for 200 km. For 12,000 km 18% CO<sub>2</sub> of transported CO<sub>2</sub> is released [4]. In a more recent study emissions from ship inclusive liquefaction (indirect emission from power generation) was reported to be unlikely to result in more than 2% of transported CO<sub>2</sub> volume [9]. Using the energy data of this catalogue a CO<sub>2</sub> emission of 0.4% of the transported volume is obtained for 200 km as shown in Table 32.

The CO<sub>2</sub> emission from ship transport will in addition to the transport distance depend on factors such as ship cruising speed and the type of fuel burned (HFO, MDO, LNG, etc.).

### Application potential

Ships will be applicable for point to point transport of CO<sub>2</sub> from CO<sub>2</sub> terminal at a capture plant location to offshore storage site (e.g. to an injection vessel) or another ship terminal e.g. at CO<sub>2</sub> utilisation site. A CO<sub>2</sub> ship may also operate in a route network where it collects CO<sub>2</sub> from several capture plant sites and deliver the CO<sub>2</sub> at a common destination.

Ship transportation requires a certain minimum volume and distance to be economically favourable compared to the alternatives (pipeline and road transport).

### Typical capacities

The capacity range considered for ships in a CCS value chain are from 2,000 to 100,000 t CO<sub>2</sub> capacity. For a specific project the ship size is selected based on cost optimisation and redundancy requirements.

Only CO<sub>2</sub> carriers up to approx. 2000 t CO<sub>2</sub> is in operation today.

### Environmental and safety

The environmental impact of ship transport is mainly during the operation phase of the project. This is linked to the energy requirement and emissions from the ship.

#### Safety

Pressure tanks on ships are normally designed according to the international maritime organisation's (IMO) IGC code. The code specifies higher safety factors and margins compared to land-based pressure tanks. [12]

Because of the large volumes of CO<sub>2</sub> onboard ships or at land-based terminals, accidental release of large volumes of CO<sub>2</sub> (loss of containment scenario) is the main safety concern with ship transportation of CO<sub>2</sub>. If liquid CO<sub>2</sub> is depressurised to ambient pressure it will form a mixture of solid and gaseous CO<sub>2</sub> (approx. 50/50) at -78 °C. A large sustained release of liquid CO<sub>2</sub> will form a cold CO<sub>2</sub> gas cloud of high CO<sub>2</sub> concentration. The cloud will flow to low-points in terrain and gradually disperse in air depending on wind speed.

Sectionalisation of storage and transfer equipment, leak detection and ESD are means of risk mitigating. A risk assessment will have to be conducted for the CO<sub>2</sub> interim storage and loading operations to see if the location meets risk acceptance criteria.

### Research and development perspectives

If CO<sub>2</sub> transportation market will take off, there is a potential for development of new ship classes dedicated for CO<sub>2</sub> transport, which may reduce cost. In addition, development of new propulsion types and green shipping fuels may significantly decrease CO<sub>2</sub> emissions from ship transportation of CO<sub>2</sub>. If specialised CO<sub>2</sub> carriers are

developed it is plausible that the energy consumption can be somewhat reduced due to a more optimised design.

The fixed O&M cost is to a large extent made up of personnel costs. Development of more autonomous ships may also reduce operating cost of ship transportation.

### Examples of market standard technology

It is possible to use standard semi-refrigerated or fully pressurised gas carriers for transport of liquid CO<sub>2</sub>.

### Prediction of performance and costs

#### CAPEX

Several studies on the cost of ships for CO<sub>2</sub> transport have been reported in the literature. The energy consultancy company ElementEnergy have estimated CO<sub>2</sub> shipping cost for a UK scenario based on cost fitting to many of the available literature cost studies as shown in Figure 67. The figure distinguishes between low pressure CO<sub>2</sub> transport (6-8 bara), medium pressure (15-18 bara) and high pressure (40-50 bar). According to Figure 67, a ship equipped for the low-pressure CO<sub>2</sub> transport conditions is less than half of the cost of a ship for medium pressure. This is a remarkable cost gap which cannot be justified by cost differences between the pressure tanks alone. This may amongst others be related to poorer utilisation of ship's cargo volume as smaller pressure tanks will be used when design pressure is increased. As there is no data for the medium pressure alternative above about 12,000 t, the shown shape of the cost curve is uncertain for higher capacities. For the high-pressure conditions only a single data point is present, hence the CAPEX is highly uncertain for this alternative.

As the industrial standard today is based on CO<sub>2</sub> transport at medium pressure (15-18 bara) conditions the ship cost data for this alternative is selected for the data sheet.

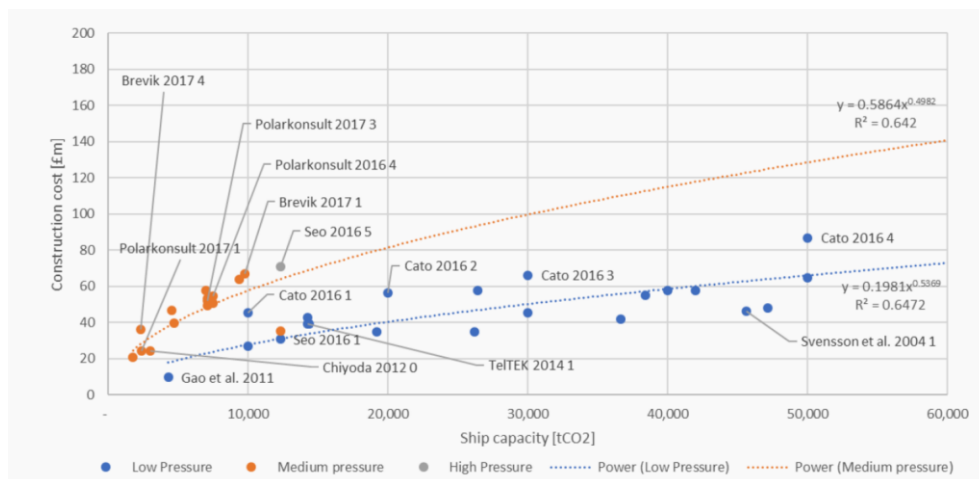

**Figure 67. Investment cost for CO<sub>2</sub> carriers as a function of capacity from [9]. Low pressure 5-8 bar, Medium pressure: 15-20 bar.**

Different opinions in the literature exist on the advantage of refurbishing old gas carriers for CO<sub>2</sub> transport compared to newbuilt. According to Gassco study [12] refurbishment of old carriers may result in cost reduction of 60% or more compared to newbuilt vessel. On the other hand, ElementEnergy [9] argues that the investment cost of the ship will only constitutes 14% of the total transport cost of CO<sub>2</sub> (when liquefaction is included) hence CAPEX saving by refurbishing old vessels has low impact on the overall cost of CO<sub>2</sub> transport.

To obtain the full CAPEX of a full CO<sub>2</sub> ship transport chain, also CO<sub>2</sub> terminals for exporting and receiving the CO<sub>2</sub> with intermediate storage facilities must be included.

CO<sub>2</sub> export terminals of two capacities (4,000 and 14,000 ton CO<sub>2</sub>) have been estimated. Facilities included in the terminals include insulated bullet tanks, CO<sub>2</sub> transfer piping, marine loading arm, loading pumps, CO<sub>2</sub> metering equipment and utilities. The terminals are estimated for CO<sub>2</sub> at 15 bara and -27°C.

### OPEX

Main OPEX elements of ship transport are ship fuel cost and O&M cost for the ship. Fixed O&M is typically estimated as 5% of CAPEX per year for ships [9]. An uncertainty on OPEX is the harbour fee e.g. for landing a tonne of cargo, which may potentially be a substantial OPEX element. Harbour fee is not estimated here. Cost of CO<sub>2</sub> liquefaction is also substantial, but this is included at the CO<sub>2</sub> capture plant.

### Levelized cost of CO<sub>2</sub> ship transport

An example of the levelized cost of CO<sub>2</sub> transport by ship is shown in Table 42. The cost is estimated to 11.2 EUR/t CO<sub>2</sub> for transport of 560,000 tpa at a distance of 500 km with a vessel size of 4000 t CO<sub>2</sub>. Also included an onshore export terminal of 5000 t CO<sub>2</sub> capacity (25% buffer capacity).

**Table 42. Example of levelized cost of CO<sub>2</sub> ship transport. Ship size is 4000 t CO<sub>2</sub>. Export terminal of 5000 t CO<sub>2</sub> is included. CO<sub>2</sub> conditions 16 bara and -26°C, transport distance 500 km each way, loading/unloading time per cycle is 24 hours.**

Parameter	Cost	Comment
<b>CAPEX 4000 t CO<sub>2</sub> ship</b>	40 mill EUR	Unit cost of 10,000 EUR/t CO <sub>2</sub> from data sheet
<b>CAPEX 5000 t CO<sub>2</sub> export terminal</b>	12.5 mill EUR	Unit cost of 2500 EUR/t CO <sub>2</sub> from data sheet.
<b>Annual. CAPEX (6%, 40 year)</b>	3.5 mill EUR/year	40 years lifetime ship (only 25 years of terminal)
<b>Fixed O&amp;M</b>	2.4 mill EUR /year	5% of CAPEX ship + 75 EUR/t CO <sub>2</sub> terminal capacity
<b>Fuel cost</b>	0.45 mil EUR/year	90 MWh/day from data sheet, 270 EUR/ton HFO,
<b>Total annual cost</b>	6.3 mil EUR/year	
<b>Annual CO<sub>2</sub> transport</b>	0.56 mill t CO <sub>2</sub> /year	8400 hrs and 140 cycles per year, 60 hour cycle time
<b>Specific transport cost</b>	<b>11.2 EUR/t CO<sub>2</sub></b>	Ex. harbour fee and taxes

The ZEP CO<sub>2</sub> transportation study [2] estimates cost of ship transport of CO<sub>2</sub> for 500 km distance at a yearly volume of 2.5 MTPA (smallest scenario) to 9.5 EUR/t CO<sub>2</sub>. This is relatively close to the estimate in Table 42. The ZEP estimate covers the low pressure transport conditions and larger vessels (30,000 t CO<sub>2</sub>) which leads to significantly lower CAPEX of the ship (Figure 67). On the other hand, the ZEP study applies higher value of capital (8%, 30 years).

### Uncertainty

As there is no commercial market for CO<sub>2</sub> transport by ship today the cost numbers are relatively uncertain. Most cost studies are based on LPG and other gas carriers, which are of relatively similar design and capacity.

## References

- 1 KNOWLEDGE SHARING REPORT – CO<sub>2</sub> Liquid Logistics Shipping Concept (LLSC) Overall Supply Chain Optimization, report 4. VOPOK, Anthony Veder, GCCSI, 21 June 2011.
- 2 The Cost of CO<sub>2</sub> Transport – Post-demonstration CCS in the EU. ZEP report 2010.
- 3 A Review of the CO<sub>2</sub> pipeline Infrastructure in the USA. Presentation by DOE/NETL April 21, 2015. DOE/NETL-2014/1681.
- 4 IPCC Special Report on Carbon Dioxide Capture and Storage. IPCC 2005. Cambridge University Press.
- 5 S. Peletiri, N. Rahmanian, I. M. Mujtaba. CO<sub>2</sub> Pipeline Design: A Review. Energies-11-02184.
- 6 CO<sub>2</sub> Pipeline Infrastructure. IEAGHG, GCCSI report: 2013/18. January 2014.
- 7 Knut Rutlin. Yara presentation. International CCS Conference, Langesund, May 20-21, 2015.
- 8 J. Kjärstad, R. Skagestad, N. H. Eldrup, F. Johnsson. Ship transport—A low cost and low risk CO<sub>2</sub> transport option in the Nordic countries. Int. J. of Greenhouse Gas Control 54 (2016) 168–184.
- 9 Shipping CO<sub>2</sub> - UK cost estimation study. Elementenergy. Final report for Business, Energy & Industrial Strategy Department, Nov 2018.
- 10 Northern Lights Project. Concept report. RE-PM673-00001. 2019-05-21.
- 11 Transportation and unloading of CO<sub>2</sub> by ship. CATO project, WP9 final public report. Dated 2016.04.09.
- 12 Fullskala CO<sub>2</sub> transport med skip. Gassco Concept study, Norwegian full-scale demonstration project. DG3 report dated 06.11.2017
- 13 Knutsen Shipping. The Pressurised CO<sub>2</sub> Transport Solution PCO<sub>2</sub>. Presentation Dansk Industri seminar. Fangst og lagring af CO<sub>2</sub> som klimavirkemiddel. 22 September 2020.
- 14 CO<sub>2</sub> tanker Asco: <https://www.ascoCO2.com/>
- 15 CO<sub>2</sub> pipeline infrastructure. IEAGHG / Global CCS Institute. Report: 2013/18, January 2014.

## Quantitative description

See separate Excel file for Data sheet

## 423 CO<sub>2</sub> transport by road

### Contact information:

Danish Energy Agency: Laust Riemann, [lri@ens.dk](mailto:lri@ens.dk)

Energinet.dk: Rune Duban Grandal

Author: Laust Riemann

### Publication date

November 2020

### Amendments after publication date

Date	Ref.	Description
-	-	-

### Brief technology description

Transport of CO<sub>2</sub> on road tankers is widely applied today. For transport of large amounts of CO<sub>2</sub> it is transported in liquid form similar to ship transport conditions. The conditions used for road transport of liquid CO<sub>2</sub> is 15-18 bara and -25 to -30°C. Road transport of CO<sub>2</sub> is relevant of small to medium volumes of CO<sub>2</sub> e.g. from small point source emitters to CO<sub>2</sub> utilisation facilities or export terminals.

CO<sub>2</sub> trucks may be loaded from interim storage tanks. Normally dedicated loading bays with transfer equipment and gas return lines are present. A truck of 30 t CO<sub>2</sub> capacity can be loaded with Liquid CO<sub>2</sub> in around 45 min. It can be assumed that 45min unloading time at the destination.

### Input

Except from the liquid CO<sub>2</sub> cargo, input is fuel for the truck. In the data sheet the fuel cost has been included in the estimated km price for road transport of CO<sub>2</sub>. The energy demand (fuel use) applied in the cost calculation is stated in the data sheet.

### Output

Output of liquid CO<sub>2</sub> is same as input.

### Efficiency and losses

Significant energy consumption is involved with road transport of CO<sub>2</sub>. However, for short distances the emission is not that significant compared to the amount of CO<sub>2</sub> transported. As an example, transporting 30 t CO<sub>2</sub> 25 km will result in emission of less than 1% of the CO<sub>2</sub> for a round trip.

### Application potential

Road truck transport of CO<sub>2</sub> will mainly be relevant for small to medium volumes of CO<sub>2</sub> over limited distances. This may for instances by from a CO<sub>2</sub> capture plant at a relatively small emission source and to a nearby export terminal or CO<sub>2</sub> utilisation facility. Max CO<sub>2</sub> tanker truck capacity is around 25-30 t CO<sub>2</sub> hence a large CO<sub>2</sub> point source e.g. 100 t CO<sub>2</sub>/h will imply many truckloads per hour around the clock which is often not desirable and more expensive than a pipeline.

### Typical capacities

The typical capacities of CO<sub>2</sub> road tankers are 25 to 30 ton. The annual transport capacity of a single truck will clearly decrease as the transport distance increases.



### Environmental and safety

The environmental impact of truck transport is mainly during the operation phase of the project. This is linked to high energy requirement and emissions from the truck.

#### Safety

CO<sub>2</sub> semi-trailers are accepted for road transport of CO<sub>2</sub> today. As the amount of CO<sub>2</sub> carried is relatively limited an accident involving leaking CO<sub>2</sub> will have relatively local effect. In congested areas such as in tunnels or in narrow streets dangerous levels of CO<sub>2</sub> is more likely to form in case of a large leakage.

### Examples of market standard technology

Semi-trailers with transport of liquid CO<sub>2</sub> at 15-18 bara and at -25 to -30°C is the standard technology for road transport.

### Prediction of performance and costs

Transport of CO<sub>2</sub> by truck is a standard service today, which is offered by several large transport companies. COWI has learned from commercial offers that road transport of CO<sub>2</sub> with diesel trucks with capacity of about 30 t CO<sub>2</sub> will cost around 6-8 EUR/t CO<sub>2</sub> for about 15 km and 13-18 EUR/ton CO<sub>2</sub> for 100 km distance. The cost includes loading and unloading to storage tanks and is based on transport of 400.000 tpa.

An estimate for CO<sub>2</sub> transportation cost by truck as function of capacity and distance has been derived where all cost elements (CAPEX and OPEX) have been lumped into a “fixed cost factor” (covering the time spent loading/unloading+ time share of CAPEX + O&M) as well as a variable cost factor (covering fuel consumption, time share of CAPEX + O&M, hours on road).

In the calculation of a cost factors for CO<sub>2</sub> road transport the following is assumed:

- CAPEX of semi-trailer truck with 30 t CO<sub>2</sub> load capacity (50 t gross weight) is estimated to 660,000 EUR.
- Annual maintenance is set to 4% of CAPEX and results in 1000 h unavailability per year
- Driver cost is 47 EUR/h (operation 24/7).
- Fuel consumption is 18 MJ/km (average of loaded and unloaded consumption) and fuel cost is 0.028 EUR/MJ.
- Loading and unloading time is set to 45 min each
- Average speed is 50 km/h.
- Truck CAPEX is annualized with 8% over 4 years.

With the above assumptions the cost of CO<sub>2</sub> transport is modelled at 3.8 EUR/t CO<sub>2</sub> + distance x 0.14 EUR/t CO<sub>2</sub>/km.

#### Example of cost of CO<sub>2</sub> transport

In the table below the cost of truck transport of CO<sub>2</sub> is calculated for 15 and 100 km with the cost numbers given above. This is in good agreement with experienced commercial rates.

	15 km transport	100 km transport
Fixed cost	3.8 EUR/t CO <sub>2</sub>	3.8 EUR/t CO <sub>2</sub>
Variable cost	15 x 0.14 EUR/t CO <sub>2</sub>	100 x 0.14 EUR/t CO <sub>2</sub>
<b>Total cost</b>	<b>5.9 EUR/t CO<sub>2</sub></b>	<b>17.8 EUR/t CO<sub>2</sub></b>
<b>CO<sub>2</sub> volume transported</b> (24/7 operation)	110,000 tpa	42,000 tpa

### Quantitative description

See separate Excel file for Data sheet.

### References

- 1 KNOWLEDGE SHARING REPORT – CO<sub>2</sub> Liquid Logistics Shipping Concept (LLSC) Overall Supply Chain Optimization, report 4. VOPOK, Anthony Veder, GCCSI, 21 June 2011.
- 2 The Cost of CO<sub>2</sub> Transport – Post-demonstration CCS in the EU. ZEP report 2010.
- 3 A Review of the CO<sub>2</sub> pipeline Infrastructure in the USA. Presentation by DOE/NETL April 21, 2015. DOE/NETL-2014/1681.
- 4 IPCC Special Report on Carbon Dioxide Capture and Storage. IPCC 2005. Cambridge University Press.
- 5 S. Peletiri, N. Rahmanian, I. M. Mujtaba. CO<sub>2</sub> Pipeline Design: A Review. Energies-11-02184.
- 6 CO<sub>2</sub> Pipeline Infrastructure. IEAGHG, GCCSI report: 2013/18. January 2014.
- 7 Knut Rutlin. Yara presentation. International CCS Conference, Langesund, May 20-21, 2015.
- 8 J. Kjärstad, R. Skagestad, N. H. Eldrup, F. Johnsson. Ship transport—A low cost and low risk CO<sub>2</sub> transport option in the Nordic countries. Int. J. of Greenhouse Gas Control 54 (2016) 168–184.
- 9 Shipping CO<sub>2</sub> - UK cost estimation study. Elementenergy. Final report for Business, Energy & Industrial Strategy Department, Nov 2018.
- 10 Northern Lights Project. Concept report. RE-PM673-00001. 2019-05-21.
- 11 Transportation and unloading of CO<sub>2</sub> by ship. CATO project, WP9 final public report. Dated 2016.04.09.
- 12 Fullskala CO<sub>2</sub> transport med skip. Gassco Concept study, Norwegian full-scale demonstration project. DG3 report dated 06.11.2017
- 13 Knutsen Shipping. The Pressurised CO<sub>2</sub> Transport Solution PCO<sub>2</sub>. Presentation Dansk Industri seminar. Fangst og lagring af CO<sub>2</sub> som klimavirkemiddel. 22 September 2020.

14 CO<sub>2</sub> tanker Asco: <https://www.ascoCO2.com/>

15 CO<sub>2</sub> pipeline infrastructure. IEAGHG / Global CCS Institute. Report: 2013/18, January 2014.

## Introduction to CO<sub>2</sub> storage

### Contact information:

Danish Energy Agency: Christoph Wolter, [chwo@ens.dk](mailto:chwo@ens.dk)

Author: Asmus Dalsgård Nielsen, Niels Peter Christensen, Per Jørgensen, Eva Lybæk Lundsteen (Rambøll)

### Publication date

November 2021

### Amendments after publication date

Date	Ref.	Description
-	-	-

## i.1 This report

This report with the below chapter addresses a number of generic geological CO<sub>2</sub> storage options relevant for Denmark. The purpose is to create input to different activities in the Danish Energy Agency under the Ministry of Climate, Energy and Utilities on the possibilities for CCUS (Carbon Capture, Utilisation and Storage) in Denmark. The main objective is to collect and establish basic knowledge about investment requirements and operational costs for CO<sub>2</sub> storage in Denmark.

The report describes three different generic scenarios with respect to suitable geological storage sites and based on these descriptions, assessments are made regarding the investment and operational costs for three different annual storage volumes. Furthermore, some general issues related to regulatory and other requirements for CO<sub>2</sub> storage are discussed.

The three storage types, which have been analysed, are:

- Onshore saline aquifers
- Nearshore saline aquifers
- Offshore depleted oil/gas fields

The cost estimates may, when combined with cost estimates for CO<sub>2</sub> capture and transportation, be used to establish an early shadow price for Carbon Capture and Storage (CCS).

As part of the preparation of the present report, contacts have been made with different stakeholders working on developing CO<sub>2</sub> storages in Denmark and abroad. Input from stakeholders has been used as verification of project estimates during the preparation of the present report and upon finishing the draft report.

The report was made under a contract with the Danish Energy Agency within a budget corresponding to 3000 man-hours, which has restricted the level of detailing. The final version has been incorporated into the Technology Catalogue for Carbon Capture, Transport and Storage.

## i.2 Delimitation of this report – CO<sub>2</sub> storage

The present report concerns CO<sub>2</sub> storage only, while capture and transportation of CO<sub>2</sub> are described in parallel studies. In some cases, however, local infrastructure has been defined, e.g. buffer storage facilities aimed to receive CO<sub>2</sub> from the transportation option. On land, this may also include local pipelines, while for the offshore cases offloading and injection vessels have been included.

All geologic storage scenarios analysed in this study are found to be feasible and realistic.

However, the present report should not be used for decision-making for development of concrete storage projects.

### i.3 Uncertainty of cost estimation

Cost estimation is uncertain as costs, capacity etc. can only be clearly defined after design and data collection. This is the case for geological parameters where the number, location and type of wells, including material selection, will depend on detailed knowledge about the CO<sub>2</sub> stream and the reservoirs.

For the process industry, it is normal to use different categories for cost estimation. The following table is copied from AACE International Recommended Practice No. 18R-97 [1].

ESTIMATE CLASS	Primary Characteristic	Secondary Characteristic			
	LEVEL OF PROJECT DEFINITION Expressed as % of complete definition	END USAGE Typical purpose of estimate	METHODOLOGY Typical estimating method	EXPECTED ACCURACY RANGE Typical variation in low and high ranges [a]	PREPARATION EFFORT Typical degree of effort relative to least cost index of 1 [b]
Class 5	0% to 2%	Concept Screening	Capacity Factored, Parametric Models, Judgment, or Analogy	L: -20% to -50% H: +30% to +100%	1
Class 4	1% to 15%	Study or Feasibility	Equipment Factored or Parametric Models	L: -15% to -30% H: +20% to +50%	2 to 4
Class 3	10% to 40%	Budget, Authorization, or Control	Semi-Detailed Unit Costs with Assembly Level Line Items	L: -10% to -20% H: +10% to +30%	3 to 10
Class 2	30% to 70%	Control or Bid/Tender	Detailed Unit Cost with Forced Detailed Take-Off	L: -5% to -15% H: +5% to +20%	4 to 20
Class 1	50% to 100%	Check Estimate or Bid/Tender	Detailed Unit Cost with Detailed Take-Off	L: -3% to -10% H: +3% to +15%	5 to 100

Table 0-1: Cost estimation categories from AACE International Recommended Practice No. 18R-97 [1]

The estimates of the present report are in class 5 and costs are to a large degree taken from analogies from the oil and gas industry. This may result in too high costs as CO<sub>2</sub> storage may be less risky, since CO<sub>2</sub> is not flammable, and because the requirements for robustness and a high degree of availability may be less important in a carbon abatement industry. However, a fully integrated CCS value chain as an industry is not yet fully developed, and only few examples exist, and issues such as the choice of materials for wells and pipelines may require more development. Also, regulatory requirements are more stringent and thus more costly for CO<sub>2</sub> storage.

### i.4 CO<sub>2</sub> Footprint

While the purpose of CCS is to reduce CO<sub>2</sub> emissions, the activities related to storage of CO<sub>2</sub> could potentially introduce additional emissions. However, the basis for all the described concepts is that all energy required for the operation is based on green energy, e.g. power from wind turbines or green e-fuels such as ammonia.

Consequently, it should be noted that there will be some emissions from the construction of the required facilities and the operation of the facility. These have not been quantified at part of this report.

## 451 CO<sub>2</sub> storage

### Contact information:

Danish Energy Agency: Christoph Wolter, [chwo@ens.dk](mailto:chwo@ens.dk)

Author: Asmus Dalsgård Nielsen, Niels Peter Christensen, Per Jørgensen, Eva Lybæk Lundsteen (Rambøll)

### Publication date

November 2021

### Amendments after publication date

Date	Ref.	Description
-	-	-

## 1.1 Brief technology description

The full carbon capture chain consists of several elements, which all need to be in place to ensure storage of CO<sub>2</sub>:

- Capture
- Compression/liquefaction
- Intermediate storages – option at capture site and/or at storage site
- Pipeline transportation – option
- Ship transportation – option
- Geological storage

The storage part is to a certain degree linked to either ship transport, combined with intermediate storage, or pipeline transport and compression. Other kinds of transportation by truck or rail will be related to smaller scale storage than what is presented in the following section.

The simplest system will be a system consisting of capture, compression, pipeline transport and storage. Depending on the reservoir pressure in the storage, there may in addition be a need for compression or pumping at the storage facility. Such systems would benefit from a cluster of CO<sub>2</sub> sources to ensure the robustness of the system and, in case a CO<sub>2</sub> supplier ceases to deliver, to safeguard the investment in the storage and transportation components.

In cases involving several different sources, which cannot be linked to a pipeline, the system will consist of an intermediate above-ground storage (i.e. a number of storage tanks) connected to the geological storage facility by either pipeline for onshore or nearshore solutions or ship transportation for offshore solutions. These are the scenarios used in the present analysis.

For larger volumes, it may also be possible to connect the offshore storage by a pipeline from shore. This can be a new pipeline or re-use of existing pipelines which are no longer needed and can be converted to CO<sub>2</sub> transportation.

## 1.2 Maturity of storage technology and potential storage sites

Storage of CO<sub>2</sub> is a mature technology, which has been used for decades. There are many CCS projects globally, both operational and in the making. For a more detailed review, reference is made to:

- Global CCS Institute Report 2020 [2]

- ISO TC/265 TR 27923:2020 Geological storage of carbon dioxide injection operations and infrastructure (in press) [3]

Some of the **currently operating projects, of relevance to the potential Danish cases**, are briefly reviewed below.

### Sleipner, North Sea Norway

Began injection in 1996, offshore storage of CO<sub>2</sub> captured from natural gas. The natural gas has an original CO<sub>2</sub> content of about 9%, which is to be reduced to less than 2% for sales to Germany. Initially, about 1 Mt pa (Million ton per annum) CO<sub>2</sub> stored, decreasing with time. Now also CO<sub>2</sub> from satellite fields. Storage in high permeability Utsira sand through one extended reach well drilled from the Sleipner platform. Storage takes place in thick, high-quality sand with little lateral closure. Sleipner has led the development of monitoring methodology on offshore storage.

### Snøhvit, Barents Sea Norway

5-7.5% CO<sub>2</sub> is captured from natural gas aimed for LNG (Liquefied Natural Gas) production, which will be transported by ship to the market. The field is developed with subsea installations and a multiphase pipeline to shore and a CO<sub>2</sub> return pipeline. Operations began in 2016 with storage in a saline aquifer below the gas reservoir. Due to pressure build-up, the injection zone was shifted to the flank of the gas reservoir. The combination of pressure monitoring and 3D seismic was instrumental in addressing the issues.

Both the Sleipner and Snøhvit CO<sub>2</sub> storage projects were originally permitted under petroleum regulations but are now regulated under the relevant EU/EEA directives.

### Gorgon, Western Australia

Began injection in 2018. Storage of CO<sub>2</sub> from gas processing. Gas fields are located offshore, while storage takes place from a small island. Expected to reach about 4 Mt pa. Storage takes place in a monoclinical saline aquifer using water production wells for CO<sub>2</sub> plume control.

### Weyburn, Saskatchewan Canada

Oil field using CO<sub>2</sub> for improved recovery of oil from carbonates. One of the first Canadian fields with extensive R&D into CO<sub>2</sub> EOR (Enhanced Oil Recovery) and CCS. Baseline survey data used in surface liability case.

### Boundary Dam, Saskatchewan Canada

Began operations in 2014 at a coal-fired power plant block. Aim to capture about 1 Mt pa, which is sold for CO<sub>2</sub> EOR at Weyburn and any excess stored in a nearby saline aquifer. Provides a documented overview of uptime for the capture system, generally running at less than 80%

### Sacroc, Texas USA

An old, giant oil field and one of the early CO<sub>2</sub> EOR fields, going back to the 1970s proving the effectiveness of CO<sub>2</sub> as a tertiary oil production method. The use of CO<sub>2</sub> in oil fields was linked to a tax credit in the US. CO<sub>2</sub> was

used to build pressure back up to the initial reservoir pressure level, after which additional oil production occurred some ten years later. Subsequently, another nearby giant oil field, the Yates field, was also subjected to CO<sub>2</sub> EOR flood.

### Relevant demonstration projects

#### Ketzin, Brandenburg Germany

Storage of CO<sub>2</sub> in a saline aquifer in a sandstone reservoir below a former DDR natural gas storage facility. More than 70,000 tons stored, mainly commercial, food-grade CO<sub>2</sub> as well as some CO<sub>2</sub> from a power plant capture pilot. Very well-documented onshore storage activity close to Potsdam and Berlin. Excellent relations with the local population. Site now abandoned.

#### Tomakomai, Hokkaido Japan

CO<sub>2</sub> captured from a hydrogen plant. Storage well drilled from land and under the sea to an offshore storage structure. About 300,000 tons stored in all, and the site is now being monitored.

### CCS projects in the making

#### Ministry of Environment Sustainable CCS project, Japan

Began capture on 50 MW biomass power plant in Mikawa, southern Japan, in June 2020. Capture of CO<sub>2</sub> from waste incineration in Saga City is under development. Work ongoing to develop ship transportation options for offshore mid-Japan storage site. Both shuttle tankers and stationary tankers are being considered.

#### ECO2S CarbonSAFE project, Alabama-Mississippi USA

Initially aiming at capture of CO<sub>2</sub> from the Southern Company's Kemper power plant in Alabama, this project is developing saline aquifer storage capacity for up to 35-50 Mt pa from regional industries. The project is currently in Phase III drilling observation and injector wells. While US legislation for CO<sub>2</sub> EOR, where CO<sub>2</sub> is considered an oil field additive, is very different from European legislation, US requirements for CO<sub>2</sub> storage-only are as demanding as national and EU requirements in Europe.

### Several European projects for CO<sub>2</sub> storage are being developed including

#### Project Greensand, North Sea Denmark

Located in the western part of the Danish North Sea, this project aims to mature storage of ½-1½ Mt pa from 2025 in the Nini Field and up to 8 Mt pa in all the Siri Area Fields by 2030. CO<sub>2</sub> will be transported by ship directly to the offshore installation and will avoid the construction and installation of pipelines and new drill centres. The storage cost will therefore be lower than for those requiring new-build facilities. The flexible operational setup allows for CO<sub>2</sub> emitters in the Baltic Sea Region and North Sea Region to use the Greensand storage site. Greensand has, as the only Danish storage site, a certified Statement of Feasibility.

#### Project Bifrost, North Sea Denmark

The project aims to evaluate and mature CO<sub>2</sub> transport and storage in the Harald Field located in the Danish part of the North Sea. The project has an expected start-up storage capacity of 3 million tons of CO<sub>2</sub> per year (m/t pa). The related studies intend to develop and select the transport and storage concept for Project Bifrost. The project aims to reuse existing North Sea infrastructure while demonstrating CO<sub>2</sub> storage in a depleted offshore gas field and utilising additional North Sea reservoirs as well as the possibility to use the existing pipeline



infrastructure connected to the Danish shore as a step to connect to a future European cost- and climate-efficient CO<sub>2</sub> transportation system.

### Northern Lights, North Sea Norway

This project aims to store CO<sub>2</sub> in an offshore saline aquifer some 100 km off the coast of Norway. An intermediate CO<sub>2</sub> storage hub and associated harbour facilities are being built on the coast. CO<sub>2</sub> will arrive on ships and be sent via a pipeline for injection at the storage site. Wells will be developed as subsea installations and injection will be controlled from shore. Initial storage from one capture source is expected to be about 0.6 Mt pa with an upside capacity of about 1.5 Mt pa. The pipeline is designed for 4-5 Mt pa allowing for later stepwise expansion with domestic and international CO<sub>2</sub> supplies. An appraisal well has been completed and additional CCS relevant information has also been obtained in a nearby oil exploration well. The operator is making much of this information available at request.

### Acorn and Sapling, Scotland

This project, which is strongly supported by the Scottish government, is the successor of the now moth-bagged Peterhead project. The storage is to take place in an offshore, depleted sandstone oil reservoir, re-using the pipeline from St. Fergus as well as the four-well platform. The wells will be recompleted. Once the project is initiated, it is the intention to stepwise link up CO<sub>2</sub> supplies along the east coast all the way down to Grangemouth and Edinburgh, re-using existing pipeline facilities.

### Zero Carbon Humber, UK

A project to transport CO<sub>2</sub> from several industrial plants in the industrial cluster of Humber, including a hydrogen production plant with CCS at Equinor's H<sub>2</sub>H Saltend project, a carbon negative power station at Drax, decarbonised gas power station at SSE's Keadby site, additional hydrogen production capability at Uniper's Killingholme site and Scunthorpe steelworks. The industrial clusters plants will be connected by a CO<sub>2</sub> and hydrogen pipeline, and CO<sub>2</sub> will be injected into the offshore saline aquifer in the UK Southern Gas Province.

### Porthos, The Netherlands

A project to transport CO<sub>2</sub> from industry in the Port of Rotterdam and store this in depleted gas fields beneath the North Sea. Porthos stands for Port of Rotterdam CO<sub>2</sub> Transport Hub and Offshore Storage. The project aims to re-use a depleted, low-pressure gas field for storage. These fault-bounded, depleted gas fields behave as 'pressure tanks', very differently from open aquifers elsewhere in the North Sea. An existing platform, and possibly also an existing pipeline, may be considered for re-use. An earlier CCS project, the ROAD project, used the same storage concept for storage of CO<sub>2</sub> from a coal-fired power plant. A number of studies have worked on solutions to take German CO<sub>2</sub> from the Ruhrgebiet out for storage on barges on the Rhine river through Rotterdam.

### **Storage potential of the Baltic region**

The main work on the geological storage potential of the Baltic region was carried out in the EU GeoCapacity project [4], covering all Baltic states except Sweden and Finland.

Only in the far southern part of Sweden, the subsurface is comprised of sedimentary rocks suitable for storage. Oil and gas exploration data from the 1970s indicated no or little storage potential. Minor offshore storage potential may be present. For further information see <https://data.geus.dk/nordiccs/map.xhtml>. With abundant hydropower and nuclear power, Sweden has very little CO<sub>2</sub> from fossil fuel use. A number of studies are

currently under way to hook up local fossil fuel power generation and industry in the Gothenburg area to the Norwegian storage project.

Finland has no deep sedimentary deposits of any size and thus no storage potential. Through partly state-owned FORTUM, Finland is engaged in CCS as the owners of the waste incineration plant in Oslo, the likely second supplier of CO<sub>2</sub> for the Northern Light storage facility.

The map below (Figure 0-1) shows the outlined sedimentary basins in Europe.

In Estonia, the crystalline bedrock is fairly shallow, with less than the 700-800 metres depth required for CO<sub>2</sub> to be in a dense phase; thus the geology is not suitable for storage.

Latvia has maybe one or two deep sandstone structures, one being used for natural gas storage.

Lithuania (and Kaliningrad) has a number of small geological structures suitable for storage, partly in active and depleted oil fields.

Poland has considerable potential storage capacity in the giga-tonne range.

Germany has very ample storage potential in the northern parts of the country as well as in the southern alpine forelands. Limited storage potential in the offshore Baltic Sea area and virtually no capacity in the North Sea. The geology is well-mapped and documented, but German legislation makes domestic storage difficult. Germany is the largest emitter of CO<sub>2</sub> in Europe and could become a future supplier of CO<sub>2</sub> for geological storage in the Northern Light project or one of the other North Sea storage project.

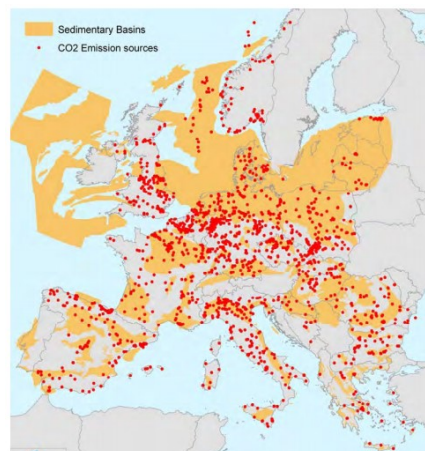

Figure 0-1: Map outlining sedimentary basins and CO<sub>2</sub> emission points in Europe [4]

Storage potential outside the Baltic region has not been described as CCS projects are already under implementation in UK, Norway and the Netherlands.

### 1.3 Maturing a CO<sub>2</sub> geological storage site

The maturity of potential CO<sub>2</sub> storage structures and reservoirs is a function of the integrated understanding of geological and other factors based on numerical models, seismic surveys, and dynamic and static well information. A methodology for assessing the maturity of potential storage sites has been developed by a working group within CSLF (Carbon Sequestration Leadership Forum). With some modification, this methodology was adapted by the Norwegian Petroleum Directorate when generating a very comprehensive atlas of the storage potential of the Norwegian continental shelf [5].

The atlas was later applied as part of the information used in screening potential storage sites in the early stages of the Northern Lights project.

Based on this methodology, an informal ranking would place the existing Danish oil and gas fields and the Stenlille gas storage structure in the upper part of the pyramid as detailed knowledge is available. The saline aquifer structures mapped from seismic coverage and the use of analogue wells (i.e. structure not drilled) by GEUS such as the Hanstholm, Havnsø, Røsnæs and Voldum structures would place in the lower part of the “realistic capacity”. The Gassum and Voldum structures would rank somewhat below Vedsted, having been mapped on older seismic data and with the structure explored by wells.

While known oil and gas structures would classify towards the top of the pyramid, a number of issues must be considered:

Legacy wells within the storage complex (location, abandonment, risk of leakage)

Storage reservoir quality (seal, porosity and permeability, geochemical issues)

- Presence of suitable cap rocks above the storage reservoir
- Porosity is very high in many chalks and high in many sandstones
- Permeability is low in chalks, reducing injectivity
- Geochemical reactions will tend to neutralise CO<sub>2</sub> in chalk, while it may produce adverse effects in some sandstones

Potential for re-use of wells, particularly long horizontal wells for chalk

Potential for re-use of infrastructure, particularly wellhead platforms

In order to further mature and move saline aquifer storage structures upwards in the pyramid, more data and more recent data is usually required, including:

- Modern seismic surveys, 2D or 3D as appropriate
- Well data, including flow testing, if feasible
- Mathematical models and predictions

With additional and more detailed information of the subsurface geology, experience shows that the geology becomes more complex and heterogeneous and simple structures often become faulted.

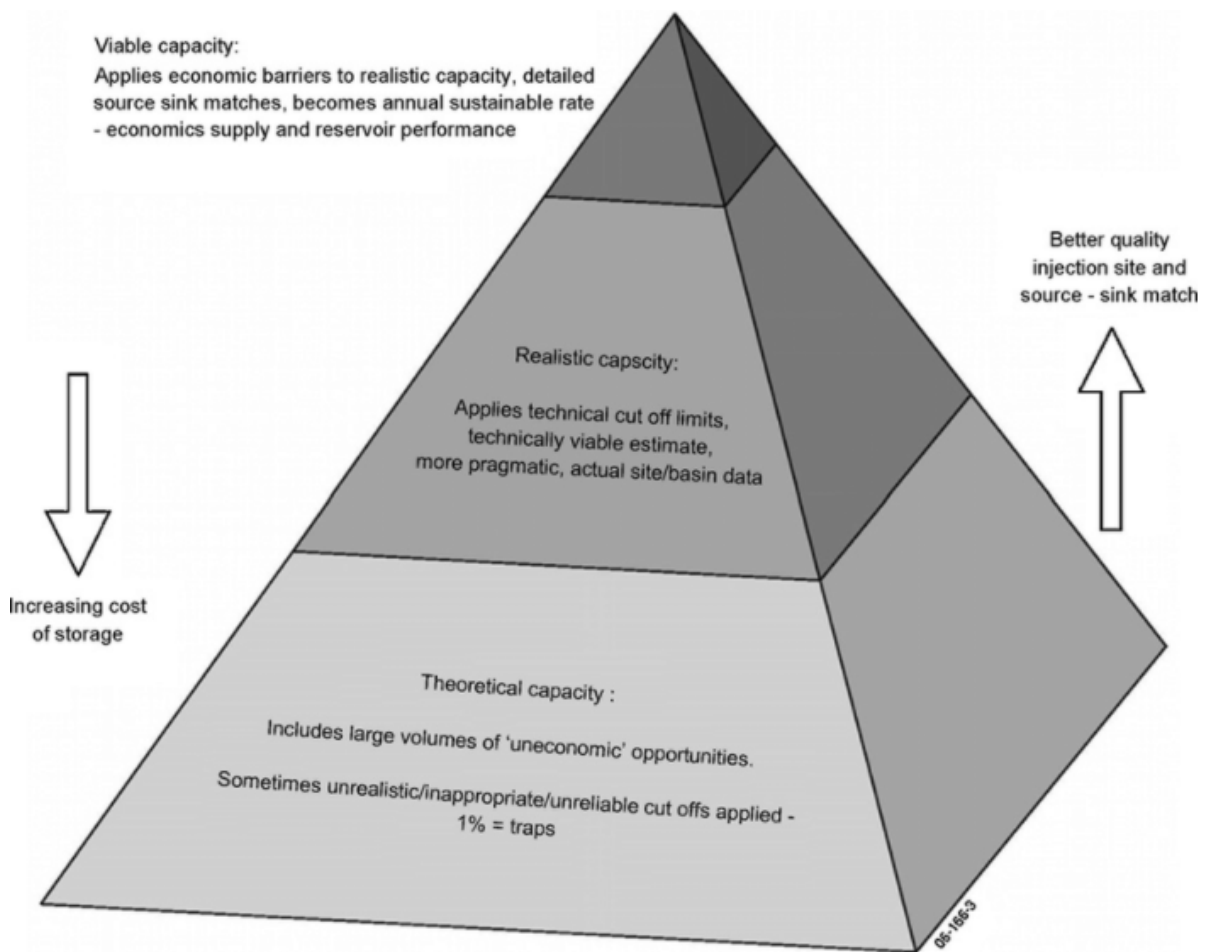

Techno-economic resource pyramid for capacity for CO<sub>2</sub> geological storage, showing the three levels of theoretical, realistic and viable estimates. Theoretical includes the entire pyramid, realistic the top two portions and viable only the top portion.

From: Bradshaw, [Bachu](#), [Binjoly](#), [Burruss](#), [Holloway](#), Christensen & Mathiassen, Int. Journal of Greenhouse Gas Control, 2007

Figure 0-2: Techno-economic resource pyramid [6]

A more recent approach to CO<sub>2</sub> geological storage maturation and classification has been presented by OGCI (Oil and Gas Climate Initiative) and Pale Blue Dot, and this methodology is more in line with the approach used for oil and gas resources. This methodology has not been applied to the Danish CO<sub>2</sub> storage potential.

Classification of CO<sub>2</sub> storage capacity has until recently been dominated by work carried out predominantly by academia. With the current focus on turning CCS operational, the industry is now increasingly engaged in turning the R&D-based work into practical use. This includes work within the Society of Petroleum Engineers (SPE).

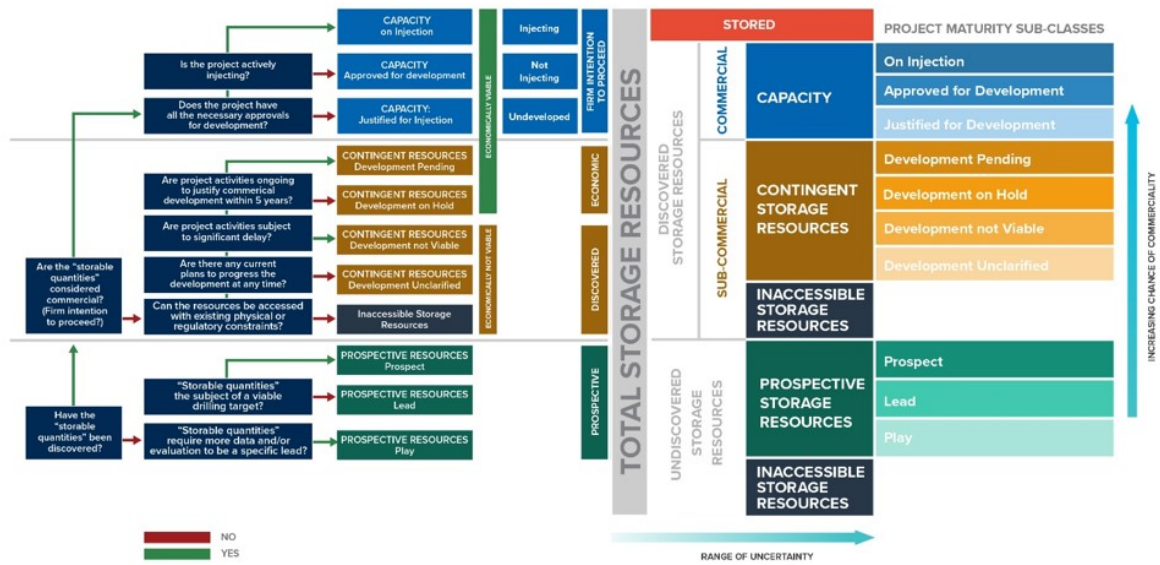

Figure 0-3: CO<sub>2</sub> geological storage maturation and classification [7]

In order to lift new storage fields to a higher level of readiness, it is necessary to carry out seismic surveys as well as appraisal drilling. This aspect is taken into account in our description of the timeline for establishing new CO<sub>2</sub> storages for saline aquifers.

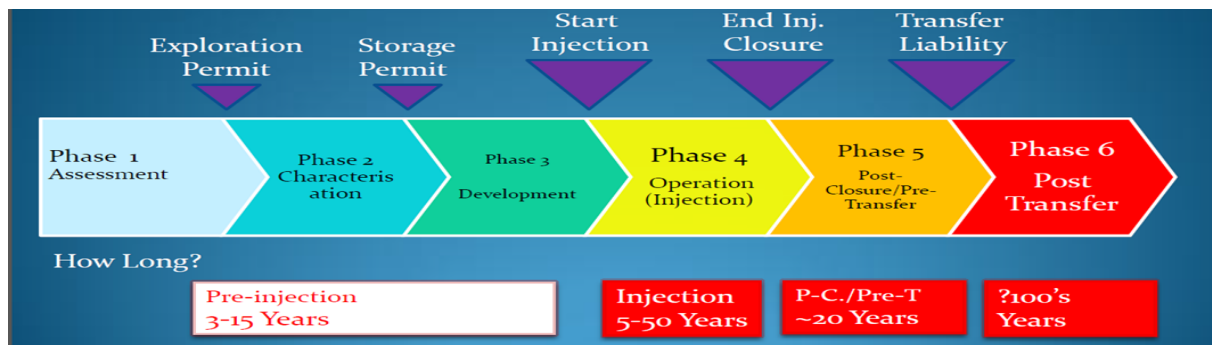

Figure 0-4: Typical phases in the development of a geological storage site [8]

### 1.4 Prediction of performance and costs

As only a few carbon storage projects have been implemented in Europe – and mostly in association with oil and gas production – there is still a lot of uncertainty about performance and cost. Implementation of projects according to the EU Directive creates some uncertainty with respect to delimitation of the operator’s responsibility after closing of the storage.

With respect to the technical development, there is uncertainty in terms of injection rates in different types of reservoirs as well as the choice of steel material for wells and pipes. Initially, we assume that a conservative approach will be used, which may tend to increase cost for the first large-scale projects. In line with operational experience, there may be a decline in cost due to more optimised design but also because the actual capacity may prove to be larger than the nameplate capacity. In addition, the cost-level seen in petroleum projects may in the longer term prove to be on the high side when dealing with non-flammable CO<sub>2</sub>.

Initially, it is assumed that the physical gap between the CO<sub>2</sub> capture location and the storage location will be bridged via ship transportation, which, in some cases, is an expensive solution compared to pipeline transportation. In high-volume cases, there may be a decline in unit cost due to economics of scale and use of pipelines, whereby the use of intermediate storage could become unnecessary. The use of pipeline for offshore solution is included as a sensitivity.

The cost of post-injection monitoring and the regulatory requirements of operator’s financial guarantee are parameters that are not well-defined at present. In line with development of more carbon storage according to the EU Directive, it is expected that such costs will be better known.

The general investment costs for CO<sub>2</sub> storage are, for the early projects, expected to follow the upstream cost for the oil and gas industry as drilling, wells, materials etc. are very much the same. The upstream capital cost index (IHS and used by IEA) in general follows oil prices, as some of the surplus income to oil and gas companies is allocated to service providers such as drilling rig operators. The upstream capital cost index is based on costs for material and personnel costs.

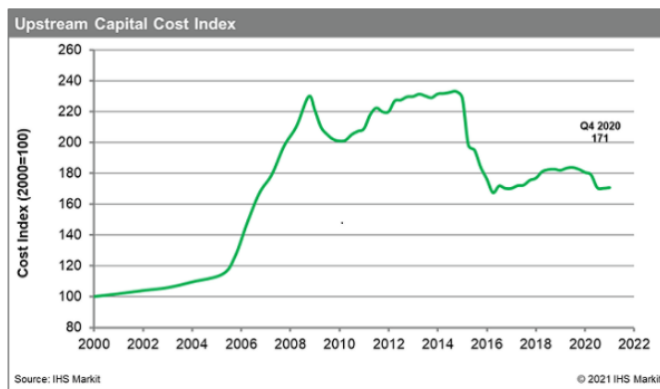

Figure 0-5: Upstream capital cost index

Apart from the general cost index, there is a general development in technology of more advanced solutions. Here the IHS upstream innovation index (UII) is a relevant measure. During the last decade there has been a gradual decline in total costs due to innovations.

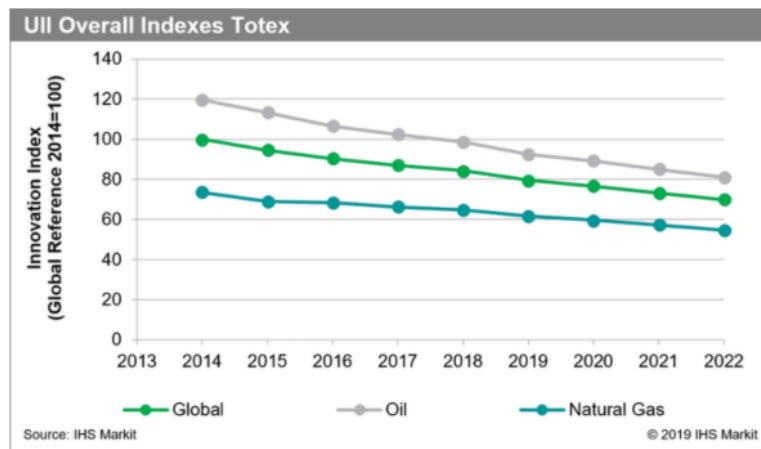

Figure 0-6: UII overall indexes Totex

For IEA stated policies scenario, it is forecasted by IEA that oil and gas production will experience a small increase and that there will be a small increase in oil and gas prices. In the sustainable development scenario, there will be a sharp decline in oil and gas production and a decline in oil and gas prices. Consequently, there is nothing in the two scenarios which indicates an increase in the investment cost index as seen before. Instead, we foresee a decline in capital cost as follows:

- Medium development:      annual decrease in fixed price of 1% per year
- High:                              constant fixed prices
- Low:                                annual decrease in fixed price of 2 % per year

The medium development is assumed to reflect the stated policy scenario and the low development reflects the sustainable development scenario.

There is some uncertainty connected to the medium development, as other sources expect offshore solutions to be more expensive than what is presented here. As some of the estimations are based on industry practice from oil and gas, there might be a bias to exclude the practice of other (established or not established) sectors from the estimation for CCS projects. Finally, the project-specific split of cost before and after Final Investment Decision, with different commercial companies having different decision gates (due to different risk willingness among others), can have an effect on the costs represented here.

### 1.5 Geological structures suitable for CO<sub>2</sub> storage

The Geological Survey of Denmark and Greenland (GEUS) has mapped a number of potential storage structures as shown on the map below, and some offshore oil and gas operators have assessed the possibility of using depleted oil and gas fields or offshore aquifers for CO<sub>2</sub> storage. The geology of Denmark is found to be well-suited for CO<sub>2</sub> storage. For further information, please refer to the excellent GEUS publication GeoViden, March 2020 ([https://issuu.com/geoviden/docs/geoviden\\_1\\_2020\\_book?fr=sYTM3YjlzODE00TA](https://issuu.com/geoviden/docs/geoviden_1_2020_book?fr=sYTM3YjlzODE00TA)).



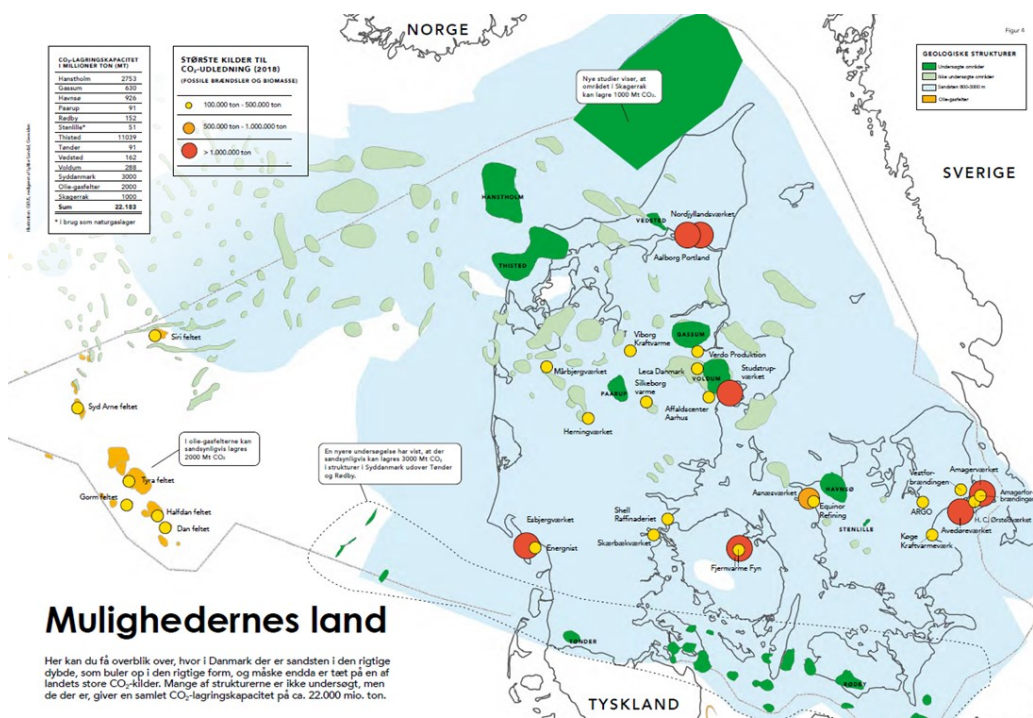

Figure 0-7: Potential CO<sub>2</sub> storage structures published by GEUS (GeoViden, March 2020)

The most suitable reservoirs for CO<sub>2</sub> storage are deep saline aquifers in sandstone or oil and gas fields in sandstone. Other reservoirs like the chalk fields, which constitute most of the Danish oil and gas fields, may also be used for CO<sub>2</sub> storage but with lower specific injection rates than for sandstone reservoirs. Both kinds of reservoirs are being assessed by commercial players.

### 1.6 Capacity calculations and variation in storage

The storage capacity is a function of, among others, the area and thickness of the reservoir, pressure and porosity. Therefore, there is a need to have good seismic surveys and proper well data from the potential reservoirs.

A regional or unconfined aquifer usually has a large area of hundreds or thousands of square kilometres. The storage capacity is a function of the hydraulic ability of the injected CO<sub>2</sub> to saturate the porosity of the reservoir. This is expressed by the storage efficiency.

Storage capacity in a regional aquifer:

$$Q = A \cdot D \cdot \varphi \cdot \rho_{CO_2} \cdot h$$

where  $Q$  is the storage capacity in kg,  $A$  is the areal distribution of the aquifer ( $m^2$ ),  $D$  is the cumulative thickness of good reservoir rocks ( $m$ ),  $\varphi$  is the effective porosity ( $<1$ ),  $h$  is the storage efficiency ( $<1$ ), and  $\rho_{CO_2}$  is the density ( $kgm^{-3}$ ) of CO<sub>2</sub> at reservoir conditions.

A confined reservoir is of more limited extent, for instance bounded by faults. When enclosed totally by barriers such as fault (or non-porous rocks), the storage will behave like a pressure tank and the storage capacity is a



function of how much pressure the system can, or is allowed, to take. This approach is particularly useful in depleted oil and gas fields.

*In a confined reservoir the storage capacity principally depends on constraining the pressure increase with respect to caprock stability, and can be written:*

$$Q = A \cdot D \cdot \phi \cdot (C_R + C_W) \cdot \Delta p \cdot \rho_{CO_2}$$

*Where:*

$C_R$  = Compressibility of the rock (grain)

$C_W$  = Compressibility of water

$\Delta p$  = Permissible pressure increase

*Source: Best Practice for the storage of CO<sub>2</sub> in saline aquifers, BGS 2008*

The injection capacity per well is one of the most important parameters for assessing costs of CO<sub>2</sub> storage as the number of wells is the main cost driver. The injection capacity will depend on cap rock strength, reservoir characteristics, as well as geometry of the storage structure and the well design. Applying highly deviated or horizontal well sections in the storage reservoir increases injectivity and CO<sub>2</sub> dispersion within the reservoir, which is favourable in particular for offshore developments where well costs are higher.

In the present study, it is estimated that injectivity per well will be in the range of about 0.5 million tonnes of CO<sub>2</sub> per year in the Gassum Formation sandstone reservoirs, which comprise the majority of the potential storage sites mapped by GEUS. This assumption is assumed also to be valid for the depleted offshore sandstone oil and gas fields in question. The use of a well injection capacity is based on a general comparison with other, high-quality reservoirs. The Sleipner Utsira Formation comprises very permeable, shallow and unconsolidated sands with an average permeability of 2 Darcy, and the injector well could presumably take several million tonnes per year with ease. The Northern Light Johanssen Formation would fall in the range of 0.5-0.6 Darcy to locally beyond 1 Darcy, and the facility is designed to take 0.6 to 1.5 Mt pa presumably from one well. The most prevalent Danish sandstone formation in question, the Gassum Formation, is of good quality with permeabilities of up to about ½ a Darcy; thus we assume an injectivity rate of about 0.5 Mt pa, occasionally – in the case of the offshore oil field storage – up to 1 Mt pa during periods when CO<sub>2</sub> is shipped in on a weekly basis. It should be noticed that the estimated 0.5 Mt pa per well is for the entire duration of the storage facility lifetime, i.e. 30 years. Experience from Canada where thousands of wells have been used for (acid) gas injection shows that the most common cause of well failure is loss of injectivity.

Use of CO<sub>2</sub> for EOR, and incidental storage, is documented to be very efficient not only in sandstone reservoirs but also in carbonate reservoirs such as in the Sacroc and Weyburn oil fields. North Sea chalk reservoirs are generally of low permeability and high porosity, thus possessing a high theoretical storage capacity but with a low injectivity rate, requiring a high transmissivity in order to be suitable for CO<sub>2</sub> injection. The transmissivity is the permeability multiplied by the length of the well in contact with the reservoir. Consequently, storage in chalk reservoirs would be of potential interest where existing long horizontal wells and other infrastructure such as wellhead platforms could be re-used. Studies on the potential for use of CO<sub>2</sub> for EOR in chalk fields in

the Norwegian and Danish sectors have indicated considerable potential, which could also be interpreted to indicate suitability for geological storage of CO<sub>2</sub>.

As there will be a need for continuous maintenance and intervention into the injector wells, it is assumed that it would be prudent to have an extra well per storage site or storage complex. Additionally, in order to avoid excessive, local pressure build-up there is a need to distribute the CO<sub>2</sub> within the storage structure, otherwise it may not be possible to utilise the entire storage volume. Exceeding the allowed reservoir pressure could lead to problems with the Competent Authority and thus with the storage permit. Typically, an offshore development for 1 Mt/year would hence require 3 wells while a development for 3 Mt/year would require 7 wells. However, these estimates are very site-specific, and after some years of operation of a storage facility it will be possible to reduce this uncertainty.

For onshore aquifers, there may be a further requirement for observation wells to ensure the integrity and compliance of the storage complex. The number of observation wells will depend on the size of the storage. There may be a need for 2 to 6 observation wells at the spill points of the storage structure depending on the results of the seismic survey and the regulatory requirements. In the quantitative assessment, 2 wells have been assumed for a 1 Mt/y development, 4 wells for a 3 Mt/y development and 6 wells for a 5 Mt/y development.

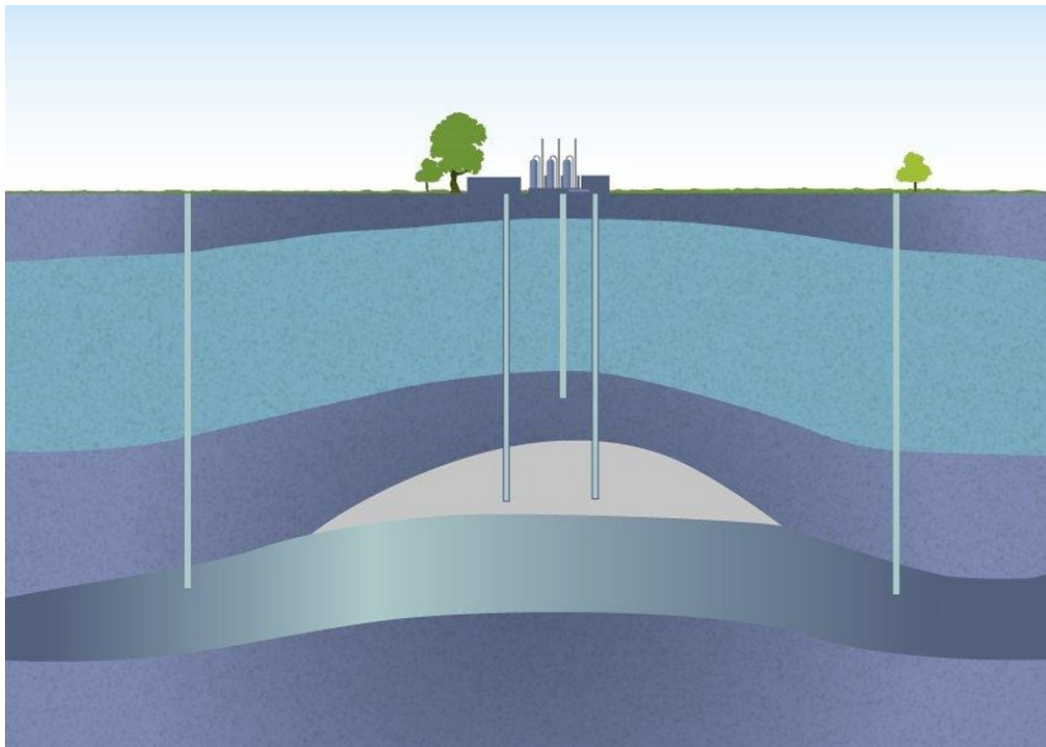

**Figure 0-8: Schematic illustration of a storage site with central injection wells and observation wells placed to monitor the flanks and the spill-point of the structure [9]**

For offshore saline aquifers and depleted oil and gas fields, there may not be the same need for spill point observation wells as marine seismic will be readily available at more frequent intervals. In oil and gas fields, containment and cap rock integrity have been assured by geologic history, and in these cases it is assumed that observation well(s) would be converted, existing wells equipped with down-hole pressure sensors.

### 1.7 Space requirements and competition with other activities

The space requirements for surface facilities for CO<sub>2</sub> storage depend on the size of the storage and type of wells to be used – horizontal or vertical. For the Stenlille gas storage, where vertical and deviated wells were drilled, there was a need for a central compression site of 100,000 m<sup>2</sup> and well sites at a distance of up to 3 km each with a size of approx. 25,000 m<sup>2</sup> and connected to the compression site with high pressure pipelines. A modern storage facility is more likely to have a central site only and to use extended reach or even horizontal wells, which will also increase the injection capacity per well. For CO<sub>2</sub> injection, the requirement for space will be less than for Stenlille as there is no need for flare and withdrawal trains, so an estimate will be less than 50,000 m<sup>2</sup>.



Figure 0-9: Stenlille gas storage [9]



Figure 0-10: Drilling rig on gas storage facility [9]

For nearshore storage facilities, it is possible to have the compression site onshore, depending on the distance from shore. Also, one particular storage site option provides the opportunity to drill wells from shore into an offshore storage reservoir. For longer distance offshore, it will be necessary to have a small wellhead platform or a subsea connection. The size of the compression site is again found to be 50,000 m<sup>2</sup>.

It is not clear if landowners that live close to a CO<sub>2</sub> storage will be eligible for compensation due to possible reduction of property value. This can among others be the case in connection with seismic surveys and installation of pipelines.

The actual value of land and expropriation needs to be based on a concrete assessment. In the following section, a unit cost of 10 m DKK is used. This number is only an indication based on assumptions that land cost is approx. 0.2 MDKK/ha for agriculture land while compensation for pipelines is approx. 500 DKK/m. If there is a need to expropriate buildings etc., the number may be different.

## 1.8 Operation of CO<sub>2</sub> storage

### 1.8.1 Handling of CO<sub>2</sub>

The properties of CO<sub>2</sub> give some challenges in terms of transportation and injection.

In order to transport large quantities of gas by ship, truck or rail, it is necessary to liquefy the gas; this can either be done by cooling, compression or a combination hereof.

In order to avoid thick wall pressure vessels, the current concept for the large LNG tankers is to liquify gas by cooling only, i.e. down to -163°C, which is the boiling temperature for liquid methane at atmospheric pressure.

The same approach is not possible for CO<sub>2</sub>, as at atmospheric pressure it would go directly from the gas phase to the solid phase if cooled below -78°C. On the other hand, the pressure vessel would be designed for 60-80 bar if no cooling was applied, which is not considered feasible due to the weight of the pressure vessels. A practical approach is operation between -50°C at 6 barg and -30°C at 14 barg. For large carriers, the pressure should be as low as practically possible.

Before the CO<sub>2</sub> is injected into the reservoir, it needs to be heated to above 0°C in order to avoid ice formation when it is in contact with formation water. This is also the case if transferred in offshore loading hoses and subsea pipelines.

In pipeline systems for transport in dense phase, the typical operating pressure is 80-125 barg and can also be higher; therefore there is no cooling requirements for CO<sub>2</sub>.

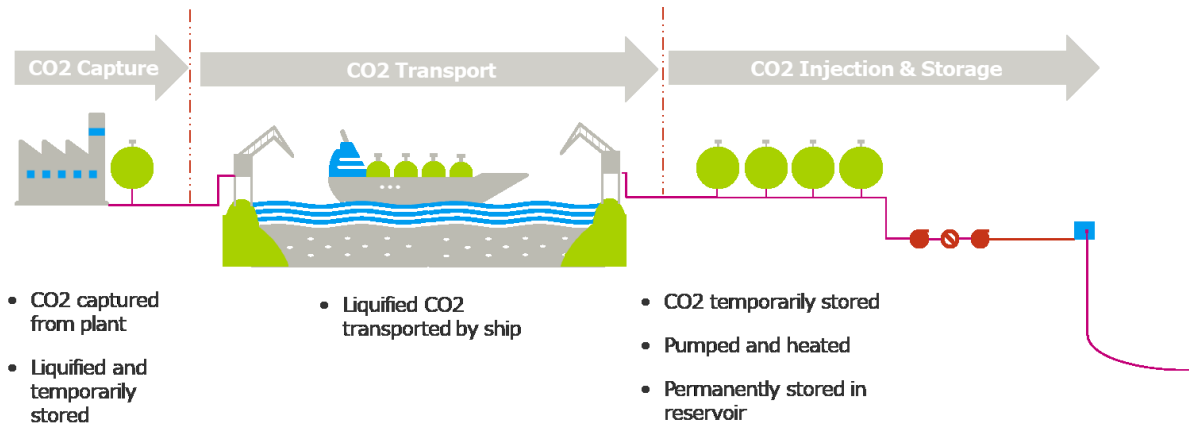

Figure 0-11: Interface between the different elements of CCS

For the present study, we have defined three cases for CO<sub>2</sub> storage:

	Reservoir and wells	Compression/pumping	Manning	Alternatives, not assessed by cost
Onshore	Onshore reservoir and well sites, new wells, intermediate storage at port and pipeline from port to site.	On site or alternatively at port facility	Normally unmanned operation	Pipeline from cluster of CO <sub>2</sub> sources directly to storage
Nearshore	Offshore reservoir, new wells, small platform, intermediate storage at port and pipeline from port to platform.	Onshore at port facility	Normally unmanned operation	Pipeline from CO <sub>2</sub> sources
Depleted oil/gas field	Reuse of existing platform and reuse of existing wells to the extent possible, SAL (single anchor loading) loading system	On vessel	Normally unmanned operation of platform, Operation from vessel	Pipeline from shore to fields. <sup>1)</sup>  Port facility to feed pipeline or onshore pipeline system to offshore pipeline.

Table 0-1: Cases for CO<sub>2</sub> storage

1) Sensitivity case described in section 1.3.5

The main difference in operation is that the offshore use of existing oil and gas platforms includes the use of a vessel with pumping facilities onboard. For both the nearshore and onshore solution, there is intermediate storage included in a port nearby. The operation of the on- and nearshore solutions does therefore not include vessel operation.

If the CO<sub>2</sub> was routed in pipelines directly from the capture site to the injection site, there would not be any requirement for an intermediate storage. However, the assumption for this study is that the bulk part of the CO<sub>2</sub> is transported by ship.

### 1.8.2 Intermediate storage onshore and near shore

Regardless of which concept is chosen, the assumption for this study is that although local CO<sub>2</sub> sources might be available, the bulk of the CO<sub>2</sub> is collected from various point sources by shuttle tanker(s) and shipped to intermediate storage close to the injection site. There may be cost savings by direct pipeline from source to storage, but the analysed concepts have been chosen to allow for flexibility and avoid storage dependency on one or a few sources.

The shuttle tankers commercially available today are relatively small, a few thousand tonnes net load, whereas the CCS volumes used as the basis for this report will require significantly larger vessels to support the economy of scale. Whether these can be 2,000, 4,000, 10,000, 20,000 tonnes or even larger net loads will depend on capture sites and the collection ports. For this study, it is assumed that vessels up to at least 20,000 tonnes will become available in the future.

For the 1 Mt/year case, a 20,000 tonnes intermediate storage will be suitable for 20,000 tonnes shuttle tanker with a weekly cycle collecting CO<sub>2</sub> from various sources and offloading close to the injection site. An intermediate storage of this size would also support two 10,000 tonnes shuttle tankers, which are not completely synchronised.

For the 3 Mt/year case, a 30,000 tonnes intermediate storage will be suitable to receive three weekly 20,000 tonnes shipments with a minimum of two days between shipments. For the 5 Mt/year case, a 50,000 tonnes intermediate storage will be suitable to receive five weekly 20,000 tonnes shipments and up to two shipments a day.

The liquid CO<sub>2</sub> is pressurised and cooled at the capture site. Although the storage tanks are well insulated, there will be continuous release from evaporation due to the heat input from the surroundings; to capture this a small CO<sub>2</sub> recovery unit is required. In the quantitative assessment, the investment and operational cost have been included for recovery units which potentially can recover up to 1% of the nominal throughput.

### 1.8.3 Intermediate storage offshore

For the 1 Mt/year case, the same vessel can be a shuttle tanker and an intermediate storage onsite and at the same time be the host for the injection facilities. Based on one weekly cycle, a vessel with 20,000 tonnes net load will be required.

The use of significantly larger shuttle tankers is not considered feasible and instead of having multiple shuttle tankers equipped with injection facilities, the 3 Mt/year and 5 Mt/year cases will require a permanently moored vessel, a so-called floating storage unit (FSU) equipped with the injection facilities.

For the 3 Mt/year case, a 30,000 tonFSU will be suitable to receive three weekly 20,000 tonnes shipments with a minimum of two days between shipments and for the 5 Mt/year case, a 50,000 tonnes FSU will be suitable to receive five weekly 20,000 tonnes shipments.

The reason for having the injection facilities on the FSU is that most of the potential offshore platforms do not have sufficient size and capacity to hold the additional installations, and those which might would no longer have any fuel gas to operate their power generation.

### 1.8.4 CO<sub>2</sub> injection

Liquid CO<sub>2</sub> from the intermediate storage (onshore or floating) is pressurised to approx. 40 barg and heated to approx. 5°C before the pressure is increased to the required injection pressure and the CO<sub>2</sub> is injected into the reservoir. The heat will be provided either from seawater or air, and during wintertime an electrical or a fired booster heater might be required to achieve the last few degrees of heating.



Once the CO<sub>2</sub> is injected into the reservoir, the CO<sub>2</sub> might come into contact with formation water and can potentially form a highly corrosive environment, for which reason it is assumed that the well tubing will have to be made out of corrosion-resistant alloys.

## 1.9 Regulation of CO<sub>2</sub> storage, liability and monitoring

### 1.9.1 EU Directive and international standards

CO<sub>2</sub> storage is regulated on EU level by the following directive:

DIRECTIVE 2009/31/EC OF THE EUROPEAN PARLIAMENT AND OF THE COUNCIL

of 23 April 2009 on the geological storage of carbon dioxide [10]

The directive refers to other legal regulations such as the London convention and the OSPAR convention as well as other EU directives and regulations.

The directive has been transposed into the Danish sub-soil act [11].

An international standard has been published for the storage of CO<sub>2</sub> in geological formations including depleted oil and gas fields. This standard, known as ISO 27914:2017 Geological Storage [12], has been adopted by the Norwegian authorities and thus by the Northern Light Project. The permit to store CO<sub>2</sub> is granted by the Norwegian Environment Agency, who is also the recipient of the financial guarantee. The license to a specific offshore area intended for CO<sub>2</sub> storage is granted by the Norwegian Petroleum Directorate.

The requirements of the directive and need for reporting will add costs to the development of new CO<sub>2</sub> storage facilities. The cost of obtaining permits and reporting is estimated at 20 MDKK per storage location.

The EU Directive and the ISO standard work with the concept of 'storage complex' as illustrated in the figure below. The operator of the storage facility defines the boundaries of the storage complex, which after approval by the Competent Authority becomes the volume inside which CO<sub>2</sub> is considered to be stored while CO<sub>2</sub> outside these boundaries constitutes leakages.

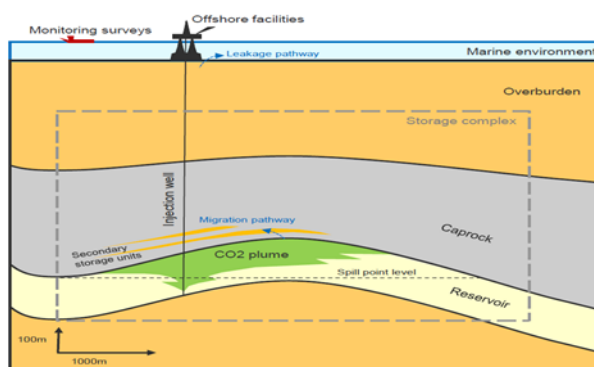

Figure 0-12: CO<sub>2</sub> storage complex [13]

### 1.9.2 Liability and insurance

In case of leakage from the storage during operation or after closing the storage, there will be a financial liability. The operator is required to post a financial guarantee, based on the risk of CO<sub>2</sub> being present outside the defined storage complex.

The financial liability will be the value of CO<sub>2</sub> on the European ETS-market at the time of leakage, according to the EU Directive 2009/31/EC on CO<sub>2</sub> storage [14]. The liability will hence be the number of tonnes of CO<sub>2</sub> leaked multiplied by the unit prices, which at present is 40 EUR/tonne. The operator will hence have double uncertainty: the future lost volumes and the future unit price.

To fully understand the cost of liability for the operators, there will be a need to apply jointly agreed risk assessment methodologies and, in the longer term, to develop an insurance market. A starting point may be for the Competent Authority to put a cap on liability.

### 1.9.3 Baseline surveys and monitoring of storage sites

#### Baseline monitoring programme

The monitoring programme, which shall be in effect before injection begins and until transfer of responsibility, shall be based on a baseline survey comprising all relevant pre-injection data pertaining to the storage complex itself supplemented by data covering the near-surface (e.g. ground water) and surface conditions (e.g. onshore and offshore biota, natural CO<sub>2</sub> flux, natural CO<sub>2</sub> compositions, etc.).

Baseline survey onshore – typical components:

- 2D or 3D seismic survey
- At least one well with ample data from reservoir, cap rock, and top hole
- Laboratory analysis of samples, especially cap rock integrity
- Storage complex numerical maps, models and predictions
- Legacy wells (location, abandonment, leakage risk)
- Well integrity monitoring
- Groundwater survey: mapping and representative sampling of water
- Natural CO<sub>2</sub> flux in representative locations above storage complex taking into account soil types, vegetation, seasonal variations, etc.

The cost of establishing the onshore baseline is estimated at 20 MDKK, and some 5 MDKK in annual follow-up cost. In addition, there is the cost of less frequent onshore seismic surveys (estimated at about 90 MDKK per survey) combined with the use of monitoring wells at spill points.

Baseline survey offshore – typical components:

- 3D seismic survey
- Storage complex model based on at least one well, or in the case of a depleted oil and gas field numerical models based on production data and operational experience, possibly supplemented by specific additional data on cap rock and reservoir susceptibility to CO<sub>2</sub>
- Legacy wells; exploration, appraisal and production wells (location, abandonment, leakage risk)
- Well integrity monitoring
- Marine pelagic and benthonic biota survey
- Seabed and survey of shallow geographical and geological features including possible natural flux of CO<sub>2</sub> or other gasses

Cost of establishing the offshore baseline is estimated at around 10 MDKK. To be repeated every 4-5 years combined with a 3D seismic survey (estimated at about 70 MDKK per survey) and model updates.



### Monitoring while injection is ongoing

Monitoring of CO<sub>2</sub> storage is very important as the purpose of the storage is to ensure the permanent removal of CO<sub>2</sub> from the atmosphere. The focus of the monitoring and reporting programme will be to document to the Competent Authority that stored CO<sub>2</sub> remains within the storage complex. Monitoring shall be carried out according to a plan which takes into account the specific geological conditions, according to Appendix II of the Directive. Monitoring is to be carried out from day one as part of the storage permit.

### Post-injection monitoring

According to the EU directive there is a need to continue monitoring for a duration of a minimum of twenty years after ending the injection, unless the operator is able to convince the competent authorities of complete and permanent storage at an earlier stage (see Figure 2-14). This monitoring is to be carried out by the operator.

Once injection ceases, the reservoir pressure will tend to dissipate and gravitational forces take over (Figure 2-13). In open saline aquifers, and in many other cases, this pressure stabilisation process is fairly quick, often being a logarithmic function. This means that a closed-in storage site tends to become stable with the CO<sub>2</sub> plume slowly migrating towards the apex of the reservoir, only driven by gravity. The dense CO<sub>2</sub> fluid plume in a storage will often have a density of approx. 0.85 g/cm<sup>3</sup> while the salty formation water would be 1.1 to 1.3 g/cm<sup>3</sup>. With time, the CO<sub>2</sub> plume, i.e. the amount of free CO<sub>2</sub>, will shrink; some of the CO<sub>2</sub> will be trapped in small pores in the reservoir, other CO<sub>2</sub> will be dissolved in the formation water while some CO<sub>2</sub> will slowly form new minerals.

### Cost of monitoring during injection and in the post-injection period

Full monitoring is to be carried out while injecting CO<sub>2</sub>. Formally, the monitoring of the post-injection period, in addition, comprises a minimum of 20 years and this is the number used in this study. We use an annual cost of 10 MDKK for onshore storage and 20 MDKK for offshore storage to cover monitoring, not including the repeated 3D seismic surveys, which are to be performed every 4 or 5 years as agreed with the Competent Authority.

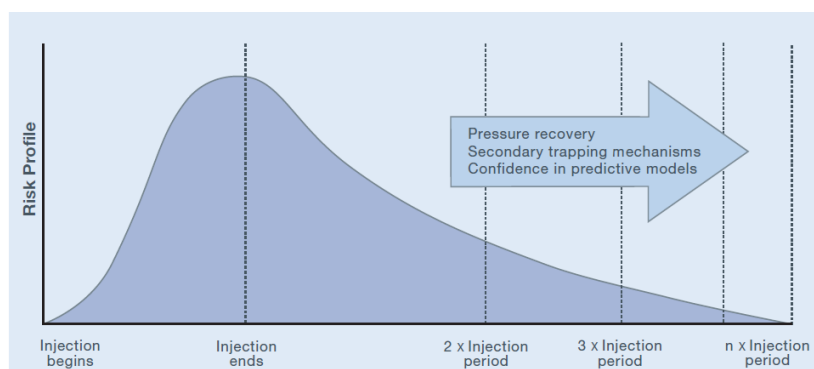

Figure 0-13: Post-injection monitoring [15]

### Transfer of responsibility

The three criteria for transfer of responsibility are listed in the figure below.

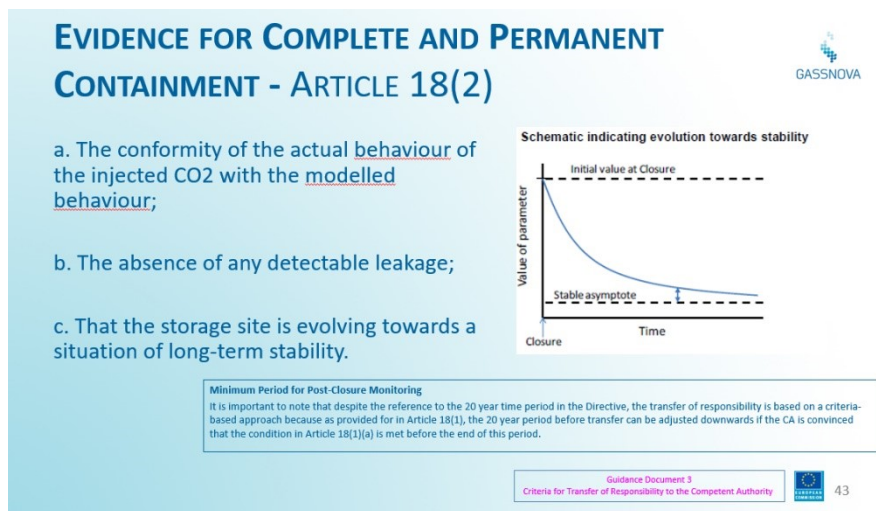

Figure 0-14: Criteria for transfer of responsibility [16]

### Post transfer financial mechanism

Once the storage licence, and thus the future responsibility for the storage site, is handed back to the Competent Authority, the operator shall provide a financial contribution, which shall at least cover the anticipated cost for the future monitoring for thirty years. As illustrated in the figures above, a storage site will stabilise with time and during the post transfer period, being up to 20 years after injection ceased, the monitoring requirements are expected to be light and thus cost-efficient. The cost of this period will be site- and project-specific, and for the current study we have not included this cost element.

## 1.10 Environmental impact and risk assessment

The storage shall be established in an environmentally safe way and fulfil relevant directives including the EU Directive for Environmental impact assessment (EIA).

As part of the EIA, there is a need to comply with the Natura 2000 areas, as some of the potential storage sites may be located within designated Natura 2000 areas.

If the storage facilities are selected as a project of common interest (PCI), there are special time restrictions on maximum duration on the handling of the authority process.

The EIA will also address risks associated with CO<sub>2</sub> storage. Experience from other similar projects, like underground gas storage and pipelines, shows that risk is an important issue which needs to be addressed in detail. It has been outside the present report to do such risk assessment, but it is recommended to carry out early studies and secure political and public acceptance at an early stage.

The cost of EIA preparation and handling of permit will be part of the CAPEX with the risk that the permits will not be obtained. Estimated cost to carry out EIA and obtaining permit is 50 MDKK per site onshore and near-shore and 20 MDKK for use of depleted oil and gas fields.

## 1.11 Use of depleted oil and gas fields

Depleted oil and gas fields can be used for CO<sub>2</sub> storage and have the advantage that the tightness of the geological system has been demonstrated. Initially, CO<sub>2</sub> injection was used for EOR (Enhanced Oil Recovery), particularly in North America, where it initially was linked to a tax credit. There are more than a hundred current

and depleted onshore US oil fields using CO<sub>2</sub> to enhance the production of oil. In the process, between 1/3 or ½ of the CO<sub>2</sub> is 'lost', i.e. incidentally stored in the reservoir. This is a very efficient storage mechanism and, thus far, more than one billion tonnes of CO<sub>2</sub> have been stored in this fashion in the US. This proves the technical validity of the concept, but in Europe, and perhaps increasingly in the US, CO<sub>2</sub> EOR is no longer considered relevant.

A number of hydrocarbon fields in the Danish North Sea are now at tail-end production and moving towards the end of commercial life within the next decade. Such fields are therefore seen as relevant for CO<sub>2</sub> storage. At this point in time, depleted oil and gas fields with sandstone reservoirs are considered most suitable for CO<sub>2</sub> storage; however, chalk fields may also be used but with a lower transmissivity, thus requiring the option to re-use existing horizontal wells.

In all cases, we expect that the initial storage of CO<sub>2</sub> will take place by use of existing platforms, which are then foreseen to be able to have the design life extended. It will be possible to reuse parts of the topside facilities such as manifolds and support systems. The possibility of using existing wells may be different from field to field depending on the materials used initially for oil and gas production, and the overall well integrity considerations. In some cases, it will be necessary with new wells or well completions and replacement of down-hole equipment. This may also include installation of pressure monitoring equipment. For the 1 and 3 Mt/y case, it is assumed that existing wells can be partly reused with new corrosion resistant tubing, whereas the 5 Mt/y case will also require drilling of new wells – for details see section 0.

Operation of the CO<sub>2</sub> injection is assumed to be based on the ship transportation of CO<sub>2</sub> to the fields with pumping of CO<sub>2</sub> from the vessel. The platform will hence not be manned during normal operation. For smaller volumes, such as 1 Mt/year, we assume that CO<sub>2</sub> will be injected in batch mode with one ship load being injected before the vessel takes another round trip. For larger volumes, we expect that it will be more optimal to have a permanently moored vessel as intermediate storage.

### 1.12 Use of existing pipelines

For large-scale injection of CO<sub>2</sub>, pipelines will be more economical than ship transport due to lower operational cost and due to continuous injection into the storage.

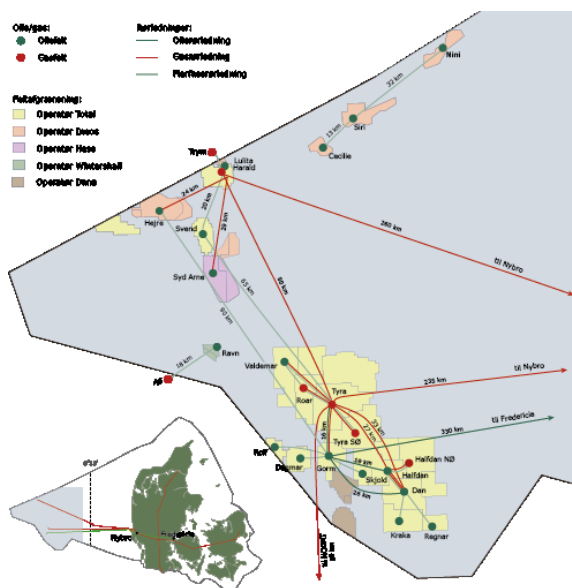

Figure 0-15: Existing pipelines

## EXHIBIT A The Transportation System A-1 Overview

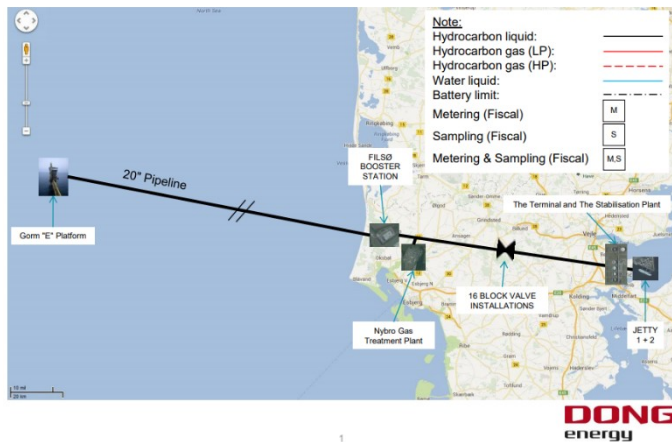

Figure 0-16: Oil transportation system [17]

The South Arne gas pipeline was originally constructed as back-up for the Tyra pipeline to ensure capacity and security of gas supply to Denmark. As the gas production is declining and Baltic Pipe connected to the Norwegian Europe II will be established in 2022, there is no longer a need for this pipeline as part of the gas transmission system. It will hence be possible to use the pipeline for other purposes such as CO<sub>2</sub> transportation or hydrogen from energy islands.

The oil pipeline system may also become redundant as domestic oil production declines. As operational cost becomes too high at low production, it will be an option to establish offshore oil loading and to use the oil pipeline for CO<sub>2</sub> transportation.

Use of the existing offshore pipelines could be connected to an intermediate storage in e.g. Esbjerg or Fredericia, or a complete onshore pipeline from the main sources to the offshore pipelines could be developed. It may also be possible to use other existing onshore pipelines for CO<sub>2</sub> transportation as part of such a system.

## Three concepts for CO<sub>2</sub> storage in Denmark

### 1.1 Onshore CO<sub>2</sub> storage – description

The geological structures below are considered to be realistic options for onshore CO<sub>2</sub> storage. See also section 1.3 for some informal comments on the maturity of the various potential storage sites.

#### Vedsted structure (storage capacity as published by GEUS: 162 Mt)

The structure is mature for further development, newer dense 2D seismic (2008) and an older exploration well on the structure itself, and another well off-structure is available.

Potential CO<sub>2</sub> sources are located in the Aalborg area, requiring a 30 km pipeline comprising: Aalborg Portland (2.2 Mt/y), the city waste incineration plant and Nordjyllandsværket power plant for a total of maybe 3 Mt/y. Other CO<sub>2</sub> sources could be captured in other urban areas such as the Aarhus area requiring an approx. 100 km pipeline or could be imported by ship to a nearby port.

#### Gassum structure (630 Mt), Voldum structure (288 Mt) and Paarup structure (91 Mt)

The three structures could be developed as storage options for central eastern Jutland. These structures were a part of an extensive mapping exercise published by Japsen and Langtofte (1991). The Gassum and Voldum structures were evaluated by oil exploration wells. Transport from CO<sub>2</sub> capture sites (power plants, CHP plants, waste-to-energy plants) to the storage site (1 Mt/y) in pipelines up to 1 Mt /y. Other CO<sub>2</sub> sources could be imported by ship to a nearby port.

#### Havnsø structure (926 Mt)

A very large and promising structure mapped from old 2D seismic of low quality. The structure has not been drilled, and the geological interpretation is based on analogy from Stenlille natural gas storage structure.

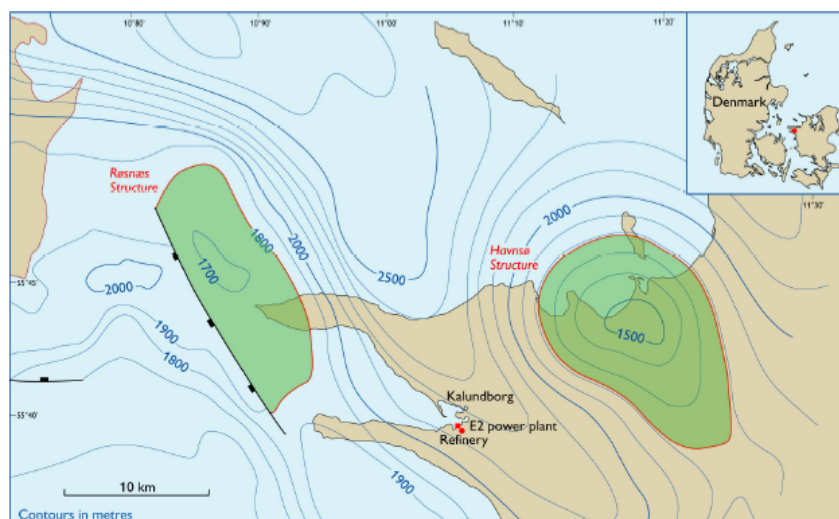

**Figure 3.14 Depth structure map of the Havnsø and Røsnæs closures. Both structures are defined in the Upper Triassic to Lower Jurassic Gassum Formation.**

Figure 0-17: Geological maps of the Havnsø and Røsnæs structures [18]

Potential CO<sub>2</sub> sources are located in the Kalundborg area (0.5 Mt/Y) requiring a 20 km pipeline from port to the injection site. Other CO<sub>2</sub> sources could be other urban areas such as the Copenhagen area, i.e. capture of CO<sub>2</sub> from e.g. Amager Resource Centre, Amager power plant, HC Ørsted power plant, Avedøre power plant, Roskilde waste incineration plant and others along the route for a total of 3 to 5 Mt/y or maybe up to 7-8 Mt/y. This would either require a pipeline across Zealand or import by ship to gathering hub in the nearby Kalundborg port.

#### Generic onshore case

The generic case assumes some local CO<sub>2</sub> capture in a port area, which can also be used for import of CO<sub>2</sub> by ship. The port facilities will include an intermediate storage from where the CO<sub>2</sub> is transferred to the injection plant through a 40 km pipeline.

##### 1.1.1 1 Mt/year onshore CO<sub>2</sub> storage

CO<sub>2</sub> is expected to be supplied to the port by shuttle tanker and stored in a 20,000 tonnes intermediate storage close to the port. The storage will consist of a number of well-insulated pressurised tanks where the CO<sub>2</sub> is stored under the same conditions as in shuttle tankers (between -50°C @ 6 barg and -30°C @ 14 barg). A recovery unit will capture and liquify the CO<sub>2</sub>, which evaporates from the tank storage.

The CO<sub>2</sub> is pumped from the storage tanks and heated with sea water and then transferred in a pipeline to the injection site where a high-pressure pump will increase the pressure to the required injection pressure to allow injection into the reservoir.

It is expected that the 1 Mt/y CO<sub>2</sub> can be injected from one well pad with five wells, two for injection, one spare and two for observation.

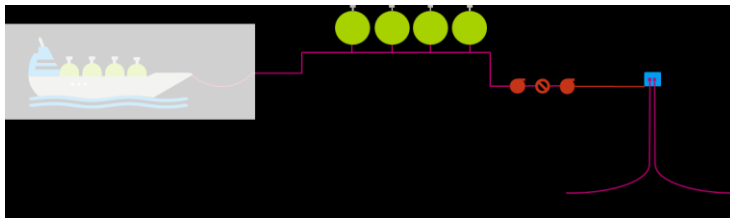

Figure 0-18: 1 Mt/year Onshore storage facility

##### 1.1.2 3 Mt/year onshore CO<sub>2</sub> storage

CO<sub>2</sub> is expected to be supplied to the port by shuttle tankers and stored in a 30,000 tonnes intermediate storage. The CO<sub>2</sub> is heated and pumped to the injection plant.

It is expected that the 3 Mt/y CO<sub>2</sub> can be injected from three well pads with four wells each, six for injection, 2 spares and 4 for observation.

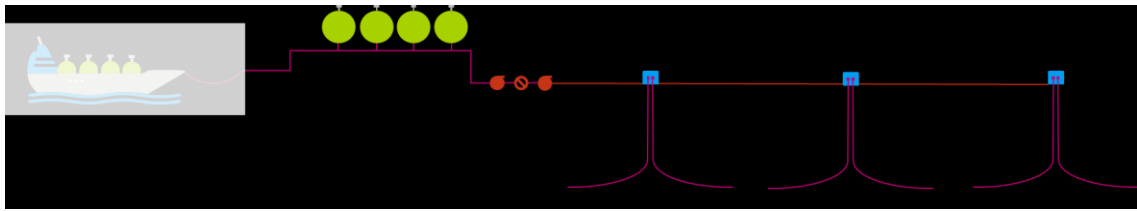

Figure 0-19: 3 Mt/year Onshore storage facility

### 1.1.3 5 Mt/year onshore CO<sub>2</sub> storage

CO<sub>2</sub> is expected to be supplied to the port by shuttle tankers and stored in a 50,000 tonnes intermediate storage. The CO<sub>2</sub> is heated and pumped to the injection plant.

It is expected that the 5 Mt/y CO<sub>2</sub> can be injected from five well pads with four wells each, 10 injection, 4 spare and 6 for observation.

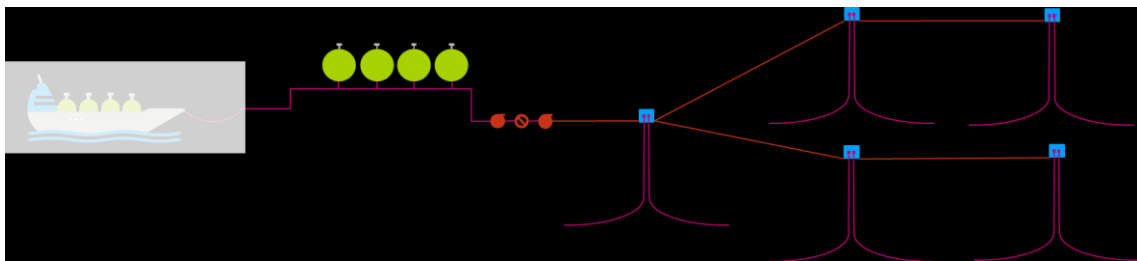

Figure 0-20: 5 Mt/year Onshore storage facility

### 1.1.4 Typical timeline for an onshore CO<sub>2</sub> storage

<b>Year</b>	<b>Activity</b>
<b>1-2</b>	Additional seismic surveys
	Appraisal well
	Conceptual studies for facilities
<b>3</b>	Environmental impact assessment, public hearings and approvals
	FEED studies
	Baseline studies
	Final Investment Decision
	Land acquisitions
<b>4-5</b>	Establish CO <sub>2</sub> terminal
	Construction of pipeline
	Establish injection plant and well pads
	Drilling of first injection and observation wells
<b>6-7</b>	Commence Injection CO <sub>2</sub>
	Evaluation of reservoir behaviour
	Investment decision for additional injection wells
<b>8-9</b>	Establish additional well pads
	Drilling of additional injection and observation wells
<b>10-35</b>	Injection at nominal capacity
	Continuous observation and seismic surveys , say every 5 years
<b>36</b>	Decommissioning of surface facilities, plug and abandonment of wells
<b>Up to next 20 years</b>	Continuous observation and seismic surveys
	Transfer of responsibility
	Release of financial security

**Table 0-2: Typical timeline for onshore CO<sub>2</sub> storage**

It may be possible to accelerate the timeline shown above depending on the priority. Based on experience from other projects in terms of the permitting process, involvement of stakeholders and internal company approval to pass Final Investment Decision, the timeline presented here may seem shorter than what is realistic. But in view of the urgency of solving the climate problem and the need for reduction of CO<sub>2</sub> content in the atmosphere, the timeline presented here is an estimation based on the assumption that the required political support will be available to realise it.



## 1.2 Nearshore CO<sub>2</sub> storage – description

Relevant geological structures have been mapped with, often older, 2D seismic and the use of analogue wells. Further maturation of the nearshore storage potential will therefore involve 3D seismic and drilling of one or several appraisal wells, some of which potentially can be reused for injection or observation. See also discussion about maturation in section 1.3.

### Hanstholm structure (2753 Mt):

This very large structure was mapped by Japsen and Langtofte (1991) and has not been evaluated by a well inside the closure. However, the Felicia-1 oil exploration well tested the Gassum Formation sandstone in a fault block adjacent to the Hanstholm structure. Detailed geological and numerical modelling was carried out by Frykman in Lothe et al., 2015: Updated estimate of storage capacity and evaluation of Seal for selected Aquifers, NORDICCS Technical Report. These studies indicate good permeability ranging between 200 and 650 mD and a theoretical storage capacity of at least 250 Mt. (see Figure 3-5 below). The expected injection site is located some 30-50 km offshore from the Port of Hanstholm. Water depth at the injection site is 30-40 m.

Import of CO<sub>2</sub> is expected to take place by ship to an intermediate storage located at an existing seaport.

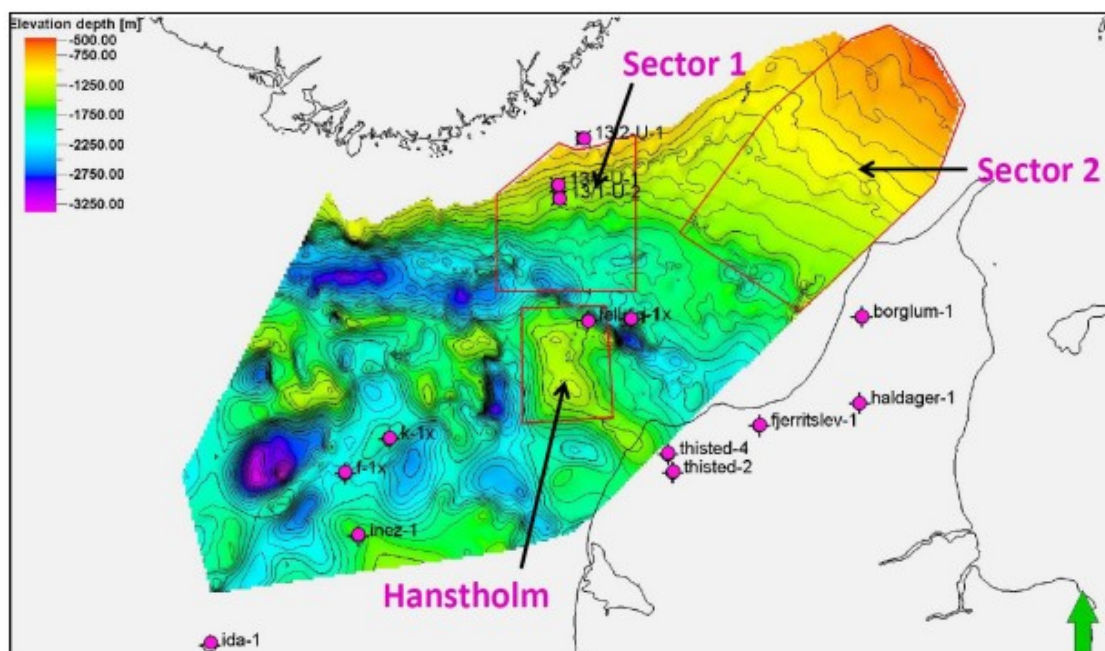

**Figure 3-1** Overview map for the top Gassum Formation surface in the Skagerrak area. The modelled areas are marked as Model 1, Model 2 and the southern Hanstholm area. Colour scale in meters.

### Figure 0-21: Geological map of the Hanstholm Structure [19]

A similar type of near-shore storage option may exist in the southern part of the North Sea, off the coast of Esbjerg, with the geological structure located some 100 km offshore. This immature option has not been specified in any detail and is considered to be included in the generic case. See the map in Figure 2.7.

### Røsnæs structure (227 Mt):

This structure is located under the Great Belt with a smaller part below the tip of Røsnæs. This means that wells could potentially be drilled from land whereas marine 3D seismic surveys could still be acquired by ship. See the map in Figure 0-17.

Due to the nature of the structure with a large fault, at least two additional appraisal wells will be required.

Potential CO<sub>2</sub> sources are located in the Kalundborg area (0.5 Mt/Y) requiring a 10-15 km pipeline. Other CO<sub>2</sub> sources could be urban areas such as the Copenhagen area, i.e. capture of CO<sub>2</sub> from e.g. Amager Bakke, Amager Værket, HC Ørsted power plant, Avedøre power plant, Roskilde waste incineration and others, a total of 3 to 5 Mt/y or maybe up to 7-8 Mt/y. This would either require a pipeline across Zealand or import to the nearby Kalundborg port.

### Generic nearshore case

The generic case assumes some local CO<sub>2</sub> capture in a port area, which can also be used for import of CO<sub>2</sub> by ship. The port facilities will include an intermediate storage and CO<sub>2</sub> injection plant from where the CO<sub>2</sub> is transferred to the injection plant through a 40 km pipeline to the nearshore injection site.

Wells will be drilled from a minimum facilities wellhead platform. Initial studies have shown that the costs of a minimum facilities wellhead platform and subsea injection development are comparable even for a few wells, and if additional wells are required, the wellhead platform option is the optimal solution.

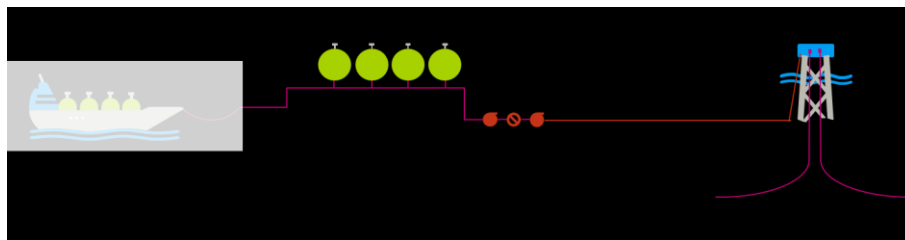

Figure 0-22: Nearshore storage facility

#### 1.2.1 1 Mt/year nearshore CO<sub>2</sub> storage

CO<sub>2</sub> is expected to be supplied to the port by shuttle tanker and stored in a 20,000 tonnes intermediate storage close to the port. The storage will consist of a number of well-insulated pressurised tanks where the CO<sub>2</sub> is stored under the same conditions as in shuttle tankers (between -50°C at 6 barg and -30°C at 14 barg). A recovery unit will capture and liquefy the CO<sub>2</sub>, which evaporates in the storage.

The CO<sub>2</sub> is pumped from the storage tanks and heated with sea water before high-pressure pumps increase the pressure to the required injection pressure to allow injection into the reservoir. The CO<sub>2</sub> is transferred in a high-pressure pipeline to the wellhead platform where the CO<sub>2</sub> can be injected directly into the reservoir.

It is expected that the 1 Mt/y CO<sub>2</sub> will require a minimum of two injection wells: one to provide redundancy and one for observation.

#### 1.2.2 3 Mt/year nearshore CO<sub>2</sub> storage

CO<sub>2</sub> is expected to be supplied to the port by shuttle tankers and stored in a 30,000 tonnes intermediate storage. The CO<sub>2</sub> is heated and then pumped to the minimum facilities wellhead platform for injection.

It is expected that the 3 Mt/y CO<sub>2</sub> will require a minimum of six injection wells, one to provide redundancy and one for observation.

### 1.2.3 5 Mt/year nearshore CO<sub>2</sub> storage

CO<sub>2</sub> is expected to be supplied to the port by shuttle tankers and stored in a 50,000 tonnes intermediate storage. The CO<sub>2</sub> is heated and then pumped to the minimum facilities wellhead platform for injection.

It is expected that the 5 Mt/y CO<sub>2</sub> will require a minimum of ten injection wells, two additional wells to provide redundancy and one for observation.

### 1.2.4 Typical timeline for a nearshore CO<sub>2</sub> storage

Year	Activity
<b>1-2</b>	Additional 3D seismic surveys
	Appraisal well
	Conceptual studies for facilities
<b>3</b>	Environmental impact assessment, public hearings and approvals
	FEED studies
	Baseline studies
	Final Investment Decision
	Land acquisitions
<b>4-5</b>	Establish CO <sub>2</sub> terminal
	Construction of pipeline
	Construction and installation of wellhead platform
	Drilling of first injection wells
<b>6-7</b>	Commence Injection CO <sub>2</sub>
	Evaluation of reservoir behaviour
	Investment decision for additional injection wells
<b>8-9</b>	Drilling of additional injection wells
<b>10-35</b>	Injection at nominal capacity
	Continuous observation and seismic surveys , say every 5 years
<b>36</b>	Decommissioning of surface facilities, plug and abandonment of wells
<b>Up to next 20 years</b>	Continuous observation of seabed and seismic surveys
	Transfer of responsibility
	Release of financial security

Table 0-3: Typical timeline for a nearshore CO<sub>2</sub> storage

It may be possible to accelerate the timeline shown above depending on priority. Based on experience from other projects in terms of the permitting process, involvement of stakeholders and internal company approval to pass Final Investment Decision, the timeline presented here may seem shorter than what is realistic. But in view of the urgency of solving the climate problem and the need for reduction of CO<sub>2</sub> content in the atmosphere, the timeline presented here is an estimation based on the assumption that the required political support will be available to realise it.

### 1.2.5 Sensitivity case – Subsea wells

Instead of drilling the wells from a minimum facilities wellhead platform, the wells can be drilled from a subsea template, which is a heavy steel structure that protects the valve assemblies on top of the wells, the manifold and the controls.

An umbilical with control signals and hydraulic fluid is routed from the subsea template to the host platform, which in this case will be onshore and 40 km away.

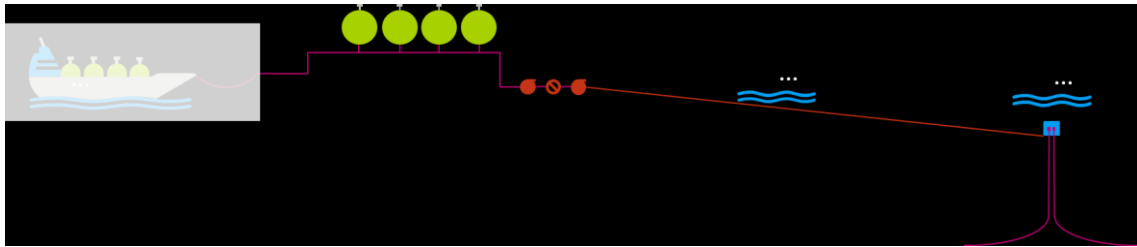

Figure 0-23: Nearshore storage facility with subsea wells

### 1.3 Offshore CO<sub>2</sub> storage – description

Oil & gas have been produced from the Danish North Sea since the early 70s, and some of the fields are approaching end of field life while others are expected to continue production until the end of the current concession.

The largest theoretical storage capacity would probably be in some of the very large chalk structures, which have been producing since the early 80s. Several of these fields are still operating or, in the case of the Tyra gas field, are currently being redeveloped. Repurposing some of the smaller, non-commercial chalk fields or suitable parts (e.g. long horizontal wells and wellhead platforms) of some of the larger chalk fields may well provide an attractive option for the utilisation of the storage capacity of the North Sea chalk reservoirs.

The focus in this report will be on the depleted northern sandstone fields, which at this point in time are considered more readily available for timely development of geological CO<sub>2</sub> storage.

The northern fields are either developed as standalone wellhead platforms or as integrated facilities with wells, process plant and accommodation; however, for this exercise these are assumed to be converted to unmanned installations.

Both the storage capacity, well tubing material and remaining lifetime vary from field to field, a factor which needs to be taken into consideration when developing a generic case. The cases below are not tailored towards one solution or operator, but known limitations are considered in order to be realistic.

Typical design lifetime of offshore production facilities are around 25 years; however, it is realistic to assume that the lifetime can be significantly increased. The first platforms in the Danish North Sea were installed in the early 70s and are after 50 years still in service and considered safe to operate. The actual lifetime of an offshore CO<sub>2</sub> storage facility may to a higher degree also be dictated by the available storage capacity.

Base case for the well conversion is that well tubing in contact with reservoir fluids must be converted to corrosion resistant material due to the risk of corrosion when CO<sub>2</sub> is mixed with saline formation water.

#### 1.3.1 1 Mt/year offshore CO<sub>2</sub> storage

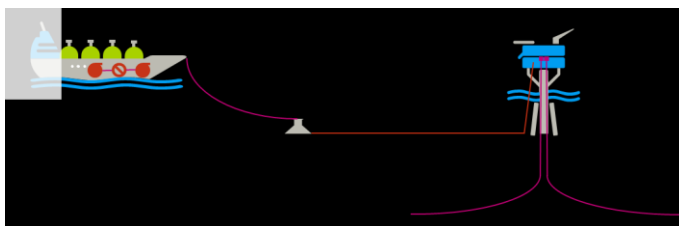

Figure 0-24: 1 Mt/year offshore storage facility

It is expected that 1 Mt of CO<sub>2</sub> per year can be injected into one depleted oil or gas field or a sector in a larger field. This will require conversion of a minimum of two wells and a third will be converted for redundancy. An additional well will be converted for use as an observation well equipped with down-hole pressure gauges.

It is expected that existing manifold and flowlines are reused to the extent possible limiting the platform modifications mainly to installation of a new riser for import of CO<sub>2</sub> from the loading boy.

CO<sub>2</sub> is expected to be supplied to the field in a CO<sub>2</sub> shuttle tanker with 20,000 tonnes capacity. In addition to operating as shuttle tanker, the vessel will also accommodate the CO<sub>2</sub> injection facilities where the CO<sub>2</sub> is heated and pressurised to the required injection pressure in order to allow direct injection of CO<sub>2</sub> on the wellhead platform.

CO<sub>2</sub> will be offloaded through a loading boy system (SAL/SBM) located approx. 3 km from the wellhead platform and transferred to the wellhead platform through a pipeline.

### 1.3.2 3 Mt/year offshore CO<sub>2</sub> storage

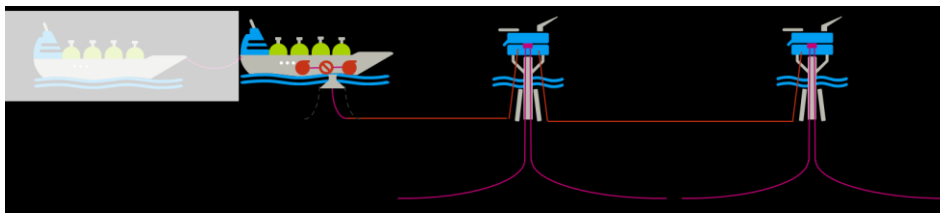

Figure 0-25: 3 Mt/year offshore storage facility

It is expected that 3 Mt of CO<sub>2</sub> per year can be injected into one larger or two smaller depleted oil or gas reservoirs or sectors. For this generic case, two depleted reservoirs or sectors are assumed, but that an existing interfield pipeline can be used to transfer the CO<sub>2</sub>.

This will require conversion of a minimum of six wells and a seventh will be converted for redundancy. An additional well will be converted for use as an observation well equipped with down-hole pressure gauges.

It is expected that the existing manifold and flowlines are reused to the extent possible limiting the platform modifications mainly to the installation of a new riser for import of CO<sub>2</sub>.

CO<sub>2</sub> is expected to be supplied to the field in shuttle tanker(s) and via a bow loading system loaded to a permanently moored vessel with up to 30,000 tonnes capacity, operating as a floating storage unit (FSU) and also accommodating the CO<sub>2</sub> injection facilities. Using a permanently moored FSU injection facilities is considered more cost-effective and operational than having multiple shuttle tankers each with dedicated injection facilities.

The FSU will have a turret mooring system, which will allow transfer of CO<sub>2</sub> to the wellhead platform through an approx. 3 km long pipeline.

### 1.3.3 5 Mt/year offshore CO<sub>2</sub> storage

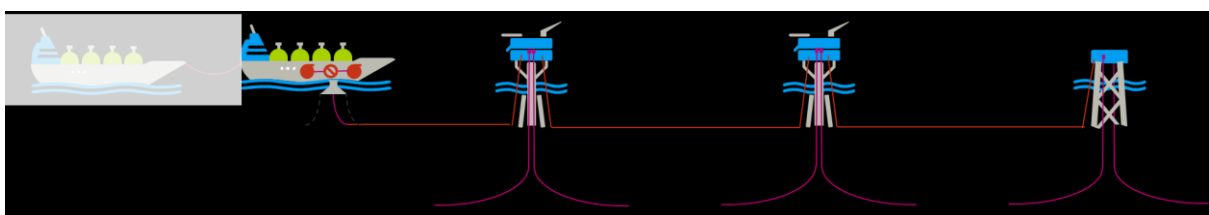

Figure 0-26: 5 Mt/year offshore storage facility

It is expected that 5 Mt of CO<sub>2</sub> per year can be injected into one larger or several smaller depleted oil or gas reservoirs or sectors. For this generic case, three depleted reservoirs or sectors are assumed. Two existing wellhead platforms are assumed to be reused, and for the third field a new wellhead platform will be installed to provide sufficient lifetime. It is assumed that existing interfield pipelines can be used for the transfer of CO<sub>2</sub>.

In total, 11 wells are assumed to be required, six conversions and five new. An additional well will be converted for use as an observation well equipped with down-hole pressure gauges.

For the existing wellhead platforms, it is expected that existing manifold and flowlines are reused to the extent possible limiting the platform modifications mainly to the installation of a new riser for the import of CO<sub>2</sub>.

CO<sub>2</sub> is expected to be supplied to the field in shuttle tanker(s) and via a bow loading system loaded to a permanently moored vessel with up to 50,000 tonnes capacity, operating as a floating storage unit (FSU) and also accommodating the CO<sub>2</sub> injection facilities.

The FSU will have a turret mooring system, which will allow transfer of CO<sub>2</sub> to the wellhead platform through an approx. 3 km long pipeline.

### 1.3.4 Typical timeline for an offshore CO<sub>2</sub> storage

Year	Activity
<b>1</b>	Evaluation of exiting production and seismic data
	Conceptual studies for facilities and purpose-built CO <sub>2</sub> Carrier/Storage Unit
<b>2</b>	Environmental impact assessment, public hearings and approvals
	FEED studies, including life-time extension studies
	Baseline studies
<b>3-4</b>	Final Investment Decision
	Construction of purpose-built CO <sub>2</sub> Carrier/Storage Unit
	Installation of mooring and loading system
	Modification of existing well platform
<b>5-6</b>	Conversion of first injection wells
	Commence Injection CO <sub>2</sub>
	Evaluation of reservoir behaviour
<b>7</b>	Investment decision for conversion of additional wells to injection wells
	Conversion of additional injection wells
<b>8-9</b>	Evaluation of reservoir behaviour and requirement for additional wells
	Conduct Concept and FEED studies for new facilities (if required)
	Environmental impact assessment, public hearings and approvals
<b>10-11</b>	Construction of pipeline
	Construction and installation of wellhead platform
	Drilling of injection wells
<b>12-35</b>	Injection at nominal capacity
	Continuous observation and seismic surveys every, say every 5 years
<b>36</b>	Decommissioning of surface facilities, plug and abandonment of wells
<b>Up to next 20 years</b>	Continuous observation of seabed and seismic surveys
	Transfer of responsibility
	Release of financial security

Table 0-4: Typical timeline for an offshore CO<sub>2</sub> storage

Based on experience from other projects in terms of the permitting process, involvement of stakeholders and internal company approval to pass Final Investment Decision, the timeline presented here may seem shorter than what is realistic. But in view of the urgency of solving the climate problem and the need for reduction of CO<sub>2</sub> content in the atmosphere, the timeline presented here is an estimation based on the assumption that the required political support will be available to realise it.

### 1.3.5 Sensitivity case – Reuse of existing offshore pipeline

According to the latest parliamentary agreement of 3 December 2020, the production of Danish oil & natural gas shall cease no later than 2050, and there may be an opportunity to utilise the Danish oil & gas pipeline grid or parts hereof for the transport of CO<sub>2</sub> for underground storage. Assessing when which parts of the grid become available is outside the scope for this report, but at least one of the gas pipelines from the offshore fields to the Nybro gas terminal may become available earlier than 2050.

Unless CO<sub>2</sub> is collected in a pipeline grid and sent to Nybro, this option will require that the CO<sub>2</sub> is shipped to a nearby port where there should be an intermediate storage from which the CO<sub>2</sub> is pumped through a new pipeline to Nybro and into e.g. the South Arne/Harald gas pipeline for injection into the Harald reservoir or other nearby reservoirs.



The maximum operating pressure in the South Arne/Harald gas pipeline is limited to approx. 135 barg, which after pipeline losses most likely is insufficient injection pressure, for which reason a high-pressure injection pump must be installed offshore. But after the cease of gas production, there will be no fuel gas available for power generation, and therefore an alternative power supply must be installed. The cost of a power cable cannot be justified and installation of a new power module/platform with liquid-fired generator driver and associated fuel storage will both result in high investments and also a high operating cost.

As power source, it is therefore suggested to install two 100% rated wind turbines providing “free” electricity. Fluctuation in the power available can be partly compensated for by controlling the export pressure from shore. However, up to 5% of the time, there will be insufficient wind to operate the wind turbines. To compensate for this, additional intermediate storage capacity is required onshore. A conservative assumption is that a total intermediate storage capacity sufficient for one week of injection is required.

A generic 5 Mt/y case could be a 100,000 tonnes intermediate storage at a port in Jutland from where is pumped to Nybro through a 40 km pipeline and transferred to one of the offshore platforms. Here CO<sub>2</sub> injection pumps are installed to inject the CO<sub>2</sub> into the reservoir. In order to provide sufficient storage capacity, it is assumed that a new wellhead platform must be installed and connected by a new pipeline, say 30 km long. Power is provided from two new 4-6 MW offshore wind turbines – the smallest commercially available today.

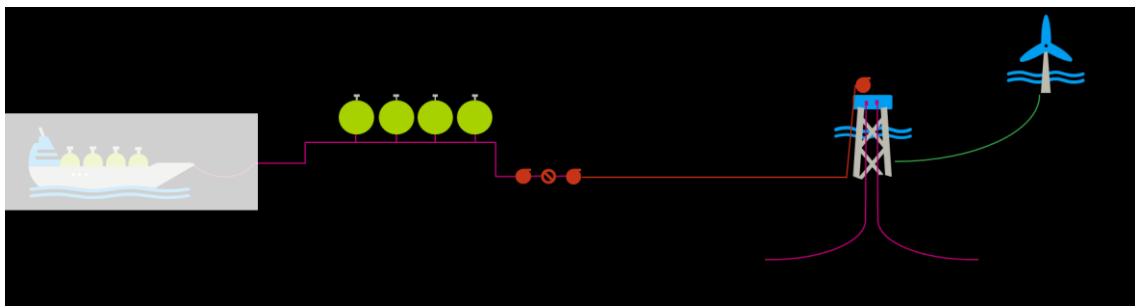

Figure 0-27: 5 Mt/year offshore storage facility

## Quantitative description

See separate Excel file for Data sheets of all cases. Input to the data sheets found below.

### 1.4 Onshore CO<sub>2</sub> storage

Case		1 Mt/year	3 Mt/year	5 Mt/year	Notes
<b>Pre-FID Cost</b>	Mill DKK				
- 2D Seismic		90	90	90	
- Baseline studies		20	20	20	
- Appraisal well		55	55	55	
- FEED Studies		10	10	10	
- Approvals		20	20	20	
<b>CAPEX</b>	Mill DKK				
- Intermediate storage		70	110	180	1
- Injection plant		105	255	420	2
- Pipeline		100	115	130	3
- Injection wells		390	945	1575	4
<b>Abandonment cost (ABEX)</b>	Mill DKK	114	255	418	
<b>Accumulated OPEX</b>	Mill DKK				6
- Base organisation		175	175	175	
- Intermediate storage		87	136	223	1
- Injection plant		130	316	521	2
- Pipeline		31	36	40	3
- Injection wells		121	275	427	4
- Monitoring		670	670	670	
- Power		204	572	884	5
<b>Post-closure Cost</b>	Mill DKK	400	400	400	
- Post-closure monitoring					
<b>CO<sub>2</sub> Injected</b>	Mill tonnes	30	84	130	
<b>Energy Consumption</b>	MJ/t CO <sub>2</sub>	49	49	49	

Table 0-5: Onshore CO<sub>2</sub> storage

#### Notes

1. Intermediate storage includes storage tanks and CO<sub>2</sub> recovery unit
2. Injection plant includes booster pumps, injection pumps, heater exchanges, boiler system
3. Pipeline between storage and injection site
4. Injection wells includes wells, manifolds and well pad
5. Energy cost is based on electrical power at 0.5 DKK/kWh
6. Accumulated OPEX is over a period of 30 years

## 1.5 Nearshore CO<sub>2</sub> storage

Case		1 Mt/year	3 Mt/year	5 Mt/year	Notes
<b>Pre-FID Cost</b>	Mill DKK				
- 3D Seismic		90	90	90	
- Baseline studies		20	20	20	
- Appraisal wells		230	230	230	
- FEED Studies		10	10	10	
- Approvals		20	20	20	
<b>CAPEX</b>	Mill DKK				
- Intermediate storage		70	110	180	1
- Injection plant		105	255	420	2
- Pipeline and power cable		305	325	340	3
- Wellhead platform		280	280	280	
- Injection wells		945	1890	2835	
<b>Abandonment cost (ABEX)</b>	Mill DKK	301	521	747	
<b>Accumulated OPEX</b>	Mill DKK				6
- Base organisation		350	350	350	
- Intermediate storage		87	136	223	1
- Injection plant		130	316	521	2
- Pipeline and power cable		95	101	105	3
- Wellhead platform		694	694	694	
- Injection wells		292	668	825	
- Monitoring		920	920	920	
- Power		204	585	884	4
<b>Post-closure Cost</b>	Mill DKK	600	600	600	
- Post-closure monitoring					
<b>CO<sub>2</sub> Injected</b>	Mill tonnes	30	86	138	
<b>Energy Consumption</b>	MJ/t CO <sub>2</sub>	49	49	49	

**Table 0-6: Nearshore CO<sub>2</sub> storage**

### Notes

1. Intermediate storage includes storage tanks and CO<sub>2</sub> recovery unit
2. Injection plant includes booster pumps, injection pumps, heater exchanges, boiler system
3. Pipeline and power cable between storage and near shore injection platform
4. Energy cost is based on electrical power at 0.5 DKK/kWh
5. Accumulated OPEX is over a period of 30 years

The CAPEX for a 1 Mt/year nearshore subsea development is about 75 Mill DKK higher as the cost difference of 100 mill between a minimum facilities wellhead platform and a subsea templet is more than outweighed by the additional cost of a control umbilical and the subsea well assemblies. Depending on requirements for well intervention operations, OPEX could both be higher or lower for the platform scenario. Overall, the assessment is that, based on the details available at this stage, it can be assumed that the costs for both concepts are almost identical.

1.6 Offshore CO<sub>2</sub> storage

Case		1 Mt/year	3 Mt/year	5 Mt/year	5 Mt/year Reuse ex. pipeline	Notes
<b>Pre-FID Cost</b>	Mill					
- 3D Seismic	DKK	50	60	70	70	
- Baseline studies		20	20	20	20	
- FEED Studies		10	10	10	10	
- Approvals		20	20	20	20	
<b>CAPEX</b>	Mill					
- Wellhead platform (incl. brownfield work)	DKK	55	80	525	545	1
- Mooring and loading system/ pipelines		135	355	375	540	2
- Purpose built CO <sub>2</sub> car- rier/FSU		475	545	640		3
- Injection plant		85	240	390	415	4, 5
- Injection wells		490	980	1925	1645	
- Onshore Storage					365	6
- Wind turbines					375	7
<b>Abandonment cost (ABEX)</b>	Mill	203	475	731	731	
	DKK					
<b>Accumulated OPEX</b>	Mill					12
- Base organisation	DKK	525	525	525	525	
- Wellhead platform		930	1740	2430	1760	8
- Mooring and loading system / pipeline		335	831	831	1224	
- Purpose-built CO <sub>2</sub> car- rier/FSU			1352	1587		13
- Injection plant		211	595	967		
- Standby vessel		620	620	620		9
- Injection wells		152	290	527	765	
- Monitoring		920	920	920	920	
- Fuel/power		690	1932	3036	605	10
- Onshore plant					967	
- Wind turbines					620	
<b>Post-closure Cost</b>	Mill	600	600	600	600	
- Post-closure monitor- ing	DKK					
<b>CO<sub>2</sub> Injected</b>	Mill tonnes	30	84	132	129	
<b>Energy Consumption</b>	MJ/t CO <sub>2</sub>	49	49	49	34 15	11

Table 0-7: Offshore CO<sub>2</sub> storage

## Notes

- For the 1 and 3 Mt/y cases, "Wellhead platform" only includes modifications to existing platform; for the 5 Mt/y cases an additional new wellhead platform at a nearby reservoir has been included
- Mooring and loading system/pipeline includes the loading/mooring buoys and the pipelines from here to the wellhead platform. For the 5 Mt/y cases an interfield pipeline is also included

3. Purpose-built CO<sub>2</sub> carrier/FSU for the 1 Mt/y includes the shuttle tanker, and for the 3 and 5 Mt/y cases a permanently moored floating storage unit
4. Injection plant includes booster pumps, injection pumps, heater exchanges, boiler system located on the purpose-built CO<sub>2</sub> carrier/FSU, except for the 5 Mt/y pipeline reuse case.
5. For 5 Mt/y pipeline reuse case booster pumps, transfer pumps, heater exchanges and boiler system are located onshore; only high-pressure injection pumps are located offshore
6. Intermediate storage includes storage tanks and CO<sub>2</sub> recovery unit
7. Wind turbines include two offshore wind turbines to provide power for the high-pressure injection pumps
8. Wellhead platform OPEX includes all OPEX for the platform(s)
9. Standby vessel covers the cost for a safety standby vessel expected to be present due to the marine operations
10. Energy cost for the operation of the injection facilities located offshore is based on a cost of 450 €/t for green ammonia, and for the onshore transfer facilities the cost is based on electrical power at 0.5 DKK/kWh
11. Energy for the offshore high-pressure injection pumps is provided by offshore wind turbines
12. Accumulated OPEX is over a period of 30 years
13. The proposed purpose-built CO<sub>2</sub> carrier proposed for the 1 Mt/y offshore CO<sub>2</sub> storage case will also be used as shuttle tanker and therefore the OPEX costs for the vessel are not being included as they are assumed to be part of "transport cost". OPEX for the injection facilities are stated as a separate line item.

### 1.7 Assumptions

The following assumptions have been used as basis for the quantitative assessments:

#### All cases

- Cost of post-injection monitoring and reporting has been included for a 20-year period
- No cost has been assessed for monitoring after hand-over to the Competent Authority
- The mandatory financial guarantee has not been evaluated at this stage, being very case-specific
- The technical lifetime of the CO<sub>2</sub> injection is for all cases set to 30 years to be comparable; however, especially for the injection into depleted oil fields, this may for some fields be significantly less, maybe as low as 15 years.

#### Onshore and nearshore

- Intermediate storage at the CO<sub>2</sub> receiving port is part of the quantitative assessments
- Pipeline from port to the injection site is part of the quantitative assessments
- Costs related to upgrade of port facilities (jetty, quayside, etc.) are not included as they are assumed to be part of "transport cost"
- Compensation to local community due to any value loss of property in the vicinity of the CO<sub>2</sub> storage or facilities is not included in the quantitative assessments

#### Offshore

- Value of existing offshore facilities at the time of transfer from production to injection is set to zero, which is considered to be realistic as the net present value of the postponement of the abandonment cost is most likely higher than any remaining value of the facilities
- All abandonment costs of existing facilities and wells are expected to be covered by the oil & gas license
- Any upside due to deferral of abandonment costs of existing facilities and wells is not taken into account
- The proposed purpose-built CO<sub>2</sub> carrier proposed for the 1 Mt/y Offshore CO<sub>2</sub> storage case will also be used as shuttle tanker, and therefore the OPEX costs for the vessel are not being included as they are assumed to be part of "transport cost"

### Energy

- Energy for the offshore CO<sub>2</sub> storage cases is assumed to be provided through CO<sub>2</sub> neutral E-fuels such as ammonia

## 1.8 Basis for cost assessment

### 1.8.1 CAPEX (capital expenditure)

The size and weight of the main components of the facilities are established based on the design capacities, whereas the size and weight of support systems and bulk items are established as typical percentages hereof. This has been used as a basis for the cost estimate, which is based on industry unit cost, mainly from the oil & gas industry.

Ships suitable to be used as CO<sub>2</sub> floating storage and host for the injection facilities have not yet been built, for which reason the costs have been extrapolated from the cost of smaller vessels such as the CO<sub>2</sub> tankers from the Northern Light project. These extrapolated costs have then been bench-marked against the cost of similarly sized LNG tankers.

Pipeline costs are mainly based on typical costs per metre onshore and offshore.

Cost of wells include cost of the well itself, surface valve assembly and tubing and the drilling costs, which include the drilling rig and associated spread cost. The day rate of an offshore drilling, especially, can vary based on the activities in the industry; for this study a cost close to the average for the past 10 years has been assumed.

### 1.8.2 OPEX (operational expenditure)

The operational expenditure for facilities, wells, pipelines and vessels is estimated based on industry norms (percentages of CAPEX) mainly from the oil and gas industry. In addition, the operational expenditure includes costs for monitoring, energy, standby vessel (where required) and support organisation.

Again, it shall be highlighted that all costs related to transportation of CO<sub>2</sub> from the capture site to an onshore intermediate storage or the offshore fields are excluded.

## 1.9 Employment in connection with CO<sub>2</sub> storage

Establishment and operation of CO<sub>2</sub> storage will create employment directly in relation with the preparation work, design and construction, operation, monitoring and abandonment. In addition, CO<sub>2</sub> storage facilities may create additional employment in relation to industries with CO<sub>2</sub> emissions as industrial plants. In the following section, only direct employment is assessed.

A typical natural gas storage uses approx. 20 full-time employees, and it has been assessed that the same number will be relevant for an onshore CO<sub>2</sub> storage as fewer people may be necessary for the plant operation, while the need for monitoring and reporting may be higher. For an onshore CO<sub>2</sub> storage, we assume 20-30 persons for operation, for nearshore 30-40 persons and for offshore solutions 60-90 persons. These differences are included in the cost estimates for operation.

Based on the estimates for operational costs, our estimate is one man-year for operation per 2.5 MDKK in OPEX for onshore plants. For offshore storage, a major part of the OPEX will be fuels and rental of vessels and by subtracting this from the OPEX, the ratio becomes approximately one man-year for 5 MDKK OPEX. Employments in relation to fuels and construction of vessels are not included.

Direct employment for investment will be lower as some part of the investment will be materials such as steel and equipment such as drilling rigs. Our estimate is that one person will be employed per 5 MDKK CAPEX. For

the investment cost, the employment may be different for on- and offshore solutions as a higher share of offshore solutions may be carried out outside Denmark. For ABEX, the same ratio is used as for CAPEX.

The total number of man-years in the different cases is consequently estimated to 1000 man-years for the 1 Mt/year onshore solution and 4000 man-years for the offshore case with 5 Mt/year.

For comparison, the Norwegian study “Industrial opportunities and employment prospects in large-scale CO<sub>2</sub> management in Norway”, published by SINTEF in 2018, assessed that the Norwegian full-scale CO<sub>2</sub> storage project, with a yearly capacity of 1.4 million tonnes CO<sub>2</sub>, would create employment of 5000 man-years for the entire CO<sub>2</sub> chain. It is estimated that 30 percent of these jobs will be for storage, corresponding to 1500 man-years.

## 1.10 Unit cost for CO<sub>2</sub> storage

### 1.10.1 Unit storage cost - NPV calculations of direct cost, CAPEX, OPEX, ABEX and monitoring

The direct unit cost for CO<sub>2</sub> storage has been calculated considering different costs of capital of 3.5%, 8% and 10% respectively to reflect the viewpoints of different stakeholders and potential investors in CO<sub>2</sub> storage. The direct cost does not include contingencies and additional risks outside the individual projects. All costs do not include taxes.

NPV per ton CO <sub>2</sub> @ WACC =	3.5%	1 MTA Onshore	3 MTA Onshore	5 MTA Onshore
CAPEX (Incl Pre FID)	DKK/t	45.9	30.3	29.7
OPEX	DKK/t	46.5	26.2	23.3
ABEX	DKK/t	2.1	1.8	1.9
Post Monitoring	DKK/t	5.3	2.0	1.3
<b>Total</b>	<b>DKK/t</b>	<b>99.9</b>	<b>60.3</b>	<b>56.3</b>

NPV per ton CO <sub>2</sub> @ WACC =	8.0%	1 MTA Onshore	3 MTA Onshore	5 MTA Onshore
CAPEX (Incl Pre FID)	DKK/t	73.9	48.3	47.3
OPEX	DKK/t	46.1	27.0	24.6
ABEX	DKK/t	0.9	0.8	0.9
Post Monitoring	DKK/t	1.6	0.6	0.4
<b>Total</b>	<b>DKK/t</b>	<b>122.6</b>	<b>76.7</b>	<b>73.2</b>

NPV per ton CO <sub>2</sub> @ WACC =	10.0%	1 MTA Onshore	3 MTA Onshore	5 MTA Onshore
CAPEX (Incl Pre FID)	DKK/t	87.9	57.4	56.3
OPEX	DKK/t	46.1	27.4	25.3
ABEX	DKK/t	0.6	0.6	0.7
Post Monitoring	DKK/t	0.9	0.4	0.3
<b>Total</b>	<b>DKK/t</b>	<b>135.6</b>	<b>85.8</b>	<b>82.6</b>

**Table 4-3: Onshore CO<sub>2</sub> storage - NPV calculation of direct cost**

## 451 CO2 storage

NPV per ton CO2 @ WACC =	3.5%	1 MTA Near shore	3 MTA Near shore	5 MTA Near shore
CAPEX (Incl Pre FID)	DKK/t	109.8	59.3	50.2
OPEX	DKK/t	91.7	43.1	33.9
ABEX	DKK/t	5.6	3.5	3.2
Post Monitoring	DKK/t	8.0	2.9	1.8
<b>Total</b>	<b>DKK/t</b>	<b>215.1</b>	<b>108.8</b>	<b>89.1</b>

NPV per ton CO2 @ WACC =	8.0%	1 MTA Near shore	3 MTA Near shore	5 MTA Near shore
CAPEX (Incl Pre FID)	DKK/t	174.5	94.5	79.8
OPEX	DKK/t	91.8	44.4	35.5
ABEX	DKK/t	2.5	1.6	1.5
Post Monitoring	DKK/t	2.4	0.9	0.6
<b>Total</b>	<b>DKK/t</b>	<b>271.2</b>	<b>141.4</b>	<b>117.4</b>

NPV per ton CO2 @ WACC =	10.0%	1 MTA Near shore	3 MTA Near shore	5 MTA Near shore
CAPEX (Incl Pre FID)	DKK/t	206.4	112.1	94.9
OPEX	DKK/t	92.2	45.2	36.4
ABEX	DKK/t	1.7	1.1	1.0
Post Monitoring	DKK/t	1.4	0.5	0.4
<b>Total</b>	<b>DKK/t</b>	<b>301.7</b>	<b>159.0</b>	<b>132.7</b>

**Table 4-4: Nearshore CO<sub>2</sub> storage - NPV calculation of direct cost**

NPV per ton CO2 @ WACC =	3.5%	1 MTA Offshore	3 MTA Offshore	5 MTA Offshore	5 MTA Offshore with SA pipeline
CAPEX (Incl Pre FID)	DKK/t	69.7	43.0	45.8	45.7
OPEX	DKK/t	145.3	106.3	89.3	59.5
ABEX	DKK/t	3.8	3.3	3.8	3.2
Post Monitoring	DKK/t	8.0	3.0	1.9	2.0
<b>Total</b>	<b>DKK/t</b>	<b>226.8</b>	<b>155.5</b>	<b>140.9</b>	<b>110.4</b>

NPV per ton CO2 @ WACC =	8.0%	1 MTA Offshore	3 MTA Offshore	5 MTA Offshore	5 MTA Offshore with SA pipeline
CAPEX (Incl Pre FID)	DKK/t	108.2	68.5	71.0	68.5
OPEX	DKK/t	145.9	109.8	93.7	64.1
ABEX	DKK/t	1.7	1.5	1.8	1.6
Post Monitoring	DKK/t	2.4	0.9	0.6	0.7
<b>Total</b>	<b>DKK/t</b>	<b>258.1</b>	<b>180.9</b>	<b>167.2</b>	<b>134.8</b>

NPV per ton CO2 @ WACC =	10.0%	1 MTA Offshore	3 MTA Offshore	5 MTA Offshore	5 MTA Offshore with SA pipeline
CAPEX (Incl Pre FID)	DKK/t	126.5	81.4	83.7	79.7
OPEX	DKK/t	146.7	111.9	96.2	66.6
ABEX	DKK/t	1.1	1.1	1.3	1.1
Post Monitoring	DKK/t	1.4	0.6	0.4	0.4
<b>Total</b>	<b>DKK/t</b>	<b>275.7</b>	<b>194.9</b>	<b>181.6</b>	<b>147.9</b>

**Table 4-5 Offshore CO<sub>2</sub> storage in depleted oil/gas fields - NPV calculation of direct cost**



The offshore CO<sub>2</sub> cost does not include the potential value of existing infrastructure such as platforms, wells and pipelines. The re-use of an existing pipeline from shore to the storage site is considered here as an option, but the cost of the acquisition of the pipeline and its eventual abandonment is not included.

### 1.10.2 Uncertainties and contingencies

The cost estimates made in the present project are associated with some uncertainty as described in chapter i.3. In order to limit the uncertainty, it will be necessary to mature the different projects, typically with more advanced design to a so-called FEED level, and potentially with additional geophysical surveys and drilling.

There are also uncertainties concerning the injection rate for the wells and the total volume, which can be stored in different geological structures or depleted hydrocarbon fields.

There are different philosophies as to how to accommodate uncertainties regarding cost and performance. For some investment projects, the uncertainties are covered by adding contingencies as the basis for the investment decision. Such contingencies have not been used in the present report.

There is some uncertainty connected to the cost estimates, as some industry players expect offshore solutions to be by up to 30% more expensive than what is presented here as a central estimate. As some of the estimations for CCS projects in this report are based on industry practice from oil and gas, other approaches might result in a variation of the cost levels, which however was out of scope for this analysis. Finally, the project-specific split of cost before and after Final Investment Decision of a specific project can have an effect on the generalized costs represented in this report, as different commercial companies may have different decision gates (among others due to different risk willingness across those companies).

### 1.10.3 Development cost – including prospects which are not developed

General overhead costs for development of a portfolio of prospects, general company costs, legal costs etc. will have to be added to the cost of individual storage development. This will also include any pre-FID costs of the initial development of storage facilities for which no investment decision will be taken.

The overall cost will naturally also depend on the chosen business model, degree of competition, tender cost, etc.

## Abbreviations and Glossary

### Abbreviation

ABEX	Abandonment Expenditure
CAPEX	Capital Expenditure
CCS	Carbon Capture and Storage
CCUS	Carbon Capture, Utilisation and Storage
CHP	Combined heat and power
CSLF	Carbon Sequestration Leadership Forum
EC	European Commission

EIA	Environmental Impact Assessment
EOR	Enhanced Oil Recovery
EU	European Union
EU ETS	EU Emissions Trading System
FEED	Front End Engineering Design
FID	Final Investment Discussion
FSU	Floating Storage Unit
GEUS	Nationale Geologiske Undersøgelser for Danmark og Grønland
IEA	International Energy Agency
IHS	IHS Markit Economics & Country Risk, Inc.
ISO	International Organization for Standardization
LNG	Liquefied Natural Gas
NOV	National Oilwell Varco
OGCI	Oil and Gas Climate Initiative
OPEX	Operational Expenditures
OSPAR	Oslo-Paris Convention
PCI	Project of Common Interest
PLEM	Pipeline end manifold
ROAD	Rotterdam Capture and Storage Demonstration Project
SAL	Single Anchor Loading (offloading system)
SBM	Single buoying moorings
UK	United Kingdom
US	United States
AACE	Association for the Advancement of Cost Engineers

### Glossary

Injection well	A well for injection of CO <sub>2</sub> into a subsurface reservoir, see an example in Figure 0-33
Observation well	A well for observation of leakages from a storage reservoir
Well pad	An area that is cleared or prepared for the drilling of wells, the area is a fenced off area with drainage and other facilities to allow safe and environmentally friendly drilling of wells, see also Figure 0-32.

Wellhead platform	<p>A steel offshore structure for the support of production and/or injection wells and associated support systems.</p> <p>See also Figure 0-29</p>
Turret	<p>The turret mooring system consists of a turret assembly that is integrated into a vessel and permanently fixed to the seabed by means of a mooring system. The turret system contains a bearing system that allows the vessel to rotate around the fixed geostatic part of the turret, which is attached to the mooring system.</p> <p>See also Figure 0-31</p>
SAL	<p>A SAL base anchored into the seabed integrates the PLEM (Pipeline End Manifold), a mooring turret and in-line swivel. The vessel can freely weathervane around the SAL subsea turret via a mooring polyester rope. Fluid is transferred through an in-line swivel and a hose string assembly up to the vessel piping at the bow.</p> <p>See also Figure 0-30</p>
SBM	<p>Single buoy mooring or single point mooring buoy consists of a buoy that is permanently moored to the seabed by means of multiple mooring lines. The buoy contains a bearing system that allows a part of it to rotate around the moored geostatic part. When moored to this rotating part of the buoy with a mooring connection, the vessel is able to freely weathervane around the geostatic part of the buoy</p>
Bow loading system	<p>The system to allow offloading from the aft of the Floating Storage Unit to the bow of shuttle tanker.</p>
Intermediate CO <sub>2</sub> storage	<p>A site with pressurised and cooled tanks for storage of liquified CO<sub>2</sub>.</p> <p>See also Figure 0-29</p>
Manifold	<p>A pipe section for distribution into several pipe segments</p>
Flowline	<p>Pipe connection between manifold and the individual wells</p>
Riser	<p>Vertical pipe section between a subsea pipeline the topside of an offshore platform</p>
Standby vessel	<p>A Safety Standby Vessel is a vessel designed rapid assistance or evacuation in the event of an emergency.</p>



Figure 0-28: Unmanned wellhead platform [20]



Figure 0-29: Typical gas storage tanks [21]

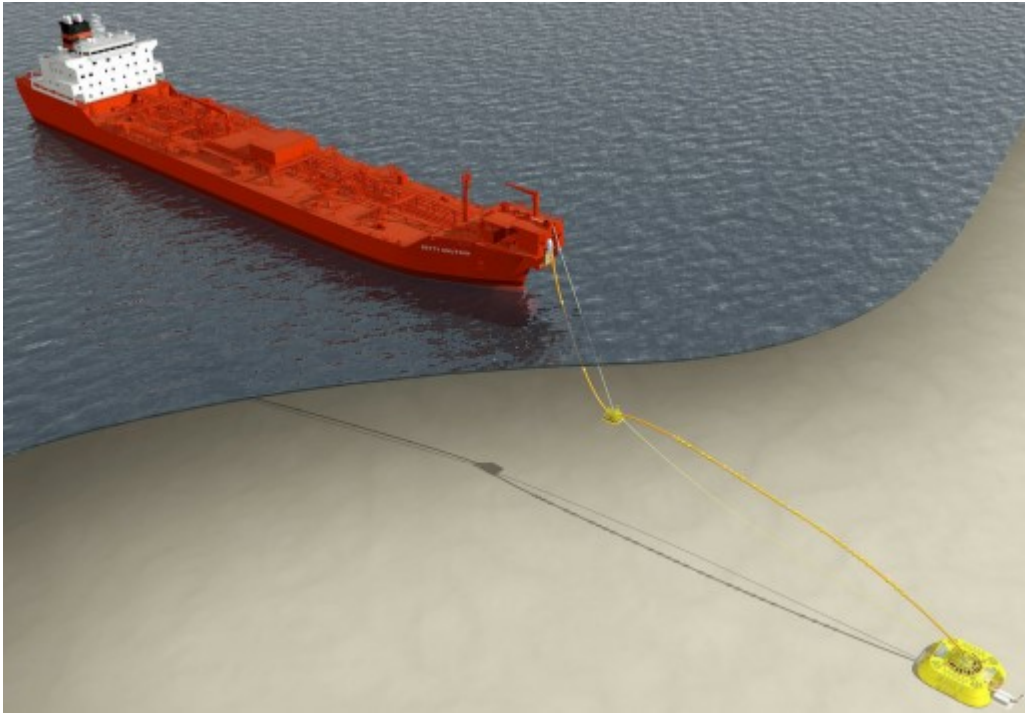

Figure 0-30: Single Anchor Loading system (NOV) [22]

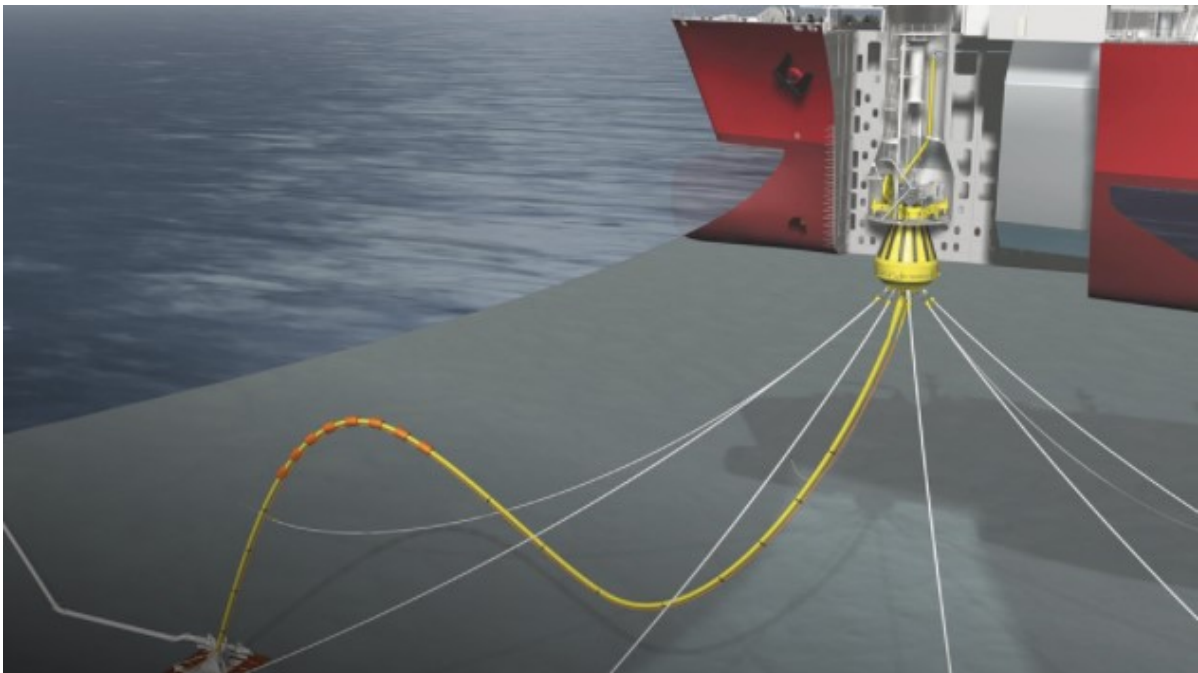

Figure 0-31: Turret mooring system [22]





Figure 0-32: Drilling operation at injection well pad [9]

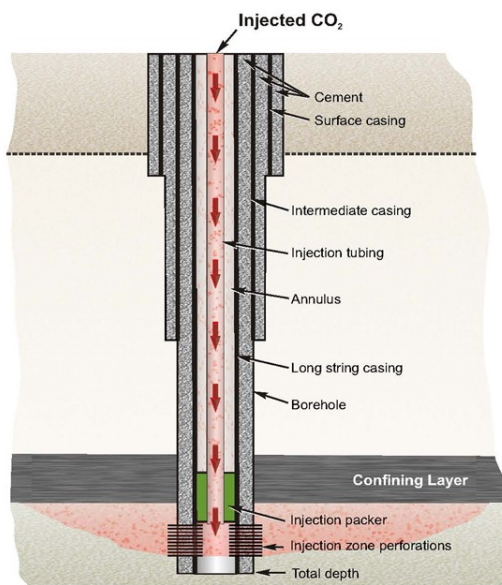

Figure 0-33: High level diagram of injection well [23]

## References

- [1] AACE International Recommended Practice No. 18R-97.
- [2] Global CCS Institute Report 2020 (the report can be accessed at: <https://www.globalccsinstitute.com/resources/global-status-report/download/>).
- [3] ISO TC/265 TR 27923:2020 Geological storage of carbon dioxide injection operations and infrastructure (in press).
- [4] EU GeoCapacity project (link: <http://www.geology.cz/geocapacity>).
- [5] Norwegian Petroleum Directorate (link: <https://www.npd.no/en/facts/carbon-storage/>).
- [6] Bradshaw, Bachu, Bonijoly, Burruss, Holloway, Christensen, Mathiassen: "CO<sub>2</sub> storage capacity estimation: Issues and development of standards", International Journal of greenhouse gas control 2, 2007.
- [7] <https://oilandgasclimateinitiative.com/co2-methodology/> 1. July 2020.
- [8] NP Christensen, CCS in Norway, Tokyo December 12-14, 2017.
- [9] Gas Storage Denmark.
- [10] DIRECTIVE 2009/31/EC OF THE EUROPEAN PARLIAMENT AND OF THE COUNCIL.
- [11] Danish sub-soil act (Undergrundsloven), paragraphs 6 and 6a.
- [12] ISO 27914:2017 Geological Storage.
- [13] Energistyrelsen.
- [14] EU Directive 2009/31/EC on CO<sub>2</sub> storage.
- [15] NP Christensen, International Regulatory Network, IEA Paris, 2015 (figure modified from Benson, Stanford U. 2007).
- [16] NP Christensen, CCS in Norway, Tokyo December 12-14, 2017.
- [17] <https://orsted.com/en/our-business/customer-solutions/intelligent-supply-and-distribution/danish-oil-pipe>.
- [18] Chadwick (ed.) et al., 2008: Best practice for storage in saline aquifers, European Commission & IEA Greenhouse Gas Programme.
- [19] Lothe, 2015.
- [20] Ramboll.
- [21] [www.roiti.com/storage/](http://www.roiti.com/storage/).
- [22] APL-NOV Ltd..
- [23] US EPA.
  - [24] GEUS publication GeoViden, March 2020 ([https://issuu.com/geoviden/docs/geoviden\\_1\\_2020\\_book?fr=sYTM3YjIzODE0OTA](https://issuu.com/geoviden/docs/geoviden_1_2020_book?fr=sYTM3YjIzODE0OTA))

