

Guide to ecodesign and energy labelling requirements for oil- or gas-fired boilers

Preface

The European Commission has published in the Official Journal 6th of September 2013 four regulations concerning ecodesign and energy labelling requirements of appliances for space heating and water heating (Regulations: 811/2013, 812/2013, 813/2013 and 814/2013). The first requirements will apply from 26th September 2015.

In order to prepare manufacturer and importers of appliances for the new requirements a number of guides are developed. Four guides are developed in the frame of the Nordic surveillance cooperation for green products (Nordsyn):

- 'Guide to ecodesign and energy labelling requirements for electric heat pumps and electric boilers'
- 'Guide to ecodesign and energy labelling requirements for electric heat pump water heaters and electric conventional water heaters'
- 'Guide to ecodesign and energy labelling requirements of hot water storage tanks'
- 'Guide to energy labelling requirements for packages of water heater and solar device'

In addition, two guides are provided by the Norwegian Water Resources and Energy Directorate (NVE):

- 'Guide to ecodesign and energy labelling requirements of oil- and gas-fired boilers'
- 'Guide to energy labelling requirements of packages of space heaters/combination heaters, temperature controls and solar devices'

Together, these guides cover the most common space and water heating appliances on the market in the Nordic countries. However, they do not cover all appliances comprised by the above mentioned regulations as for instance micro CHP appliances and gas-fired water heaters are not covered.

The individual guides use cross-referencing to the other guides when relevant. Therefore, it is recommended to have all guides available for the full benefits.

The guides present the contents of the Regulations and are addressed to manufacturers, importers and others interested. The guides are not a substitution for the Regulations, in any case of doubt, the Regulations are applicable. The guides are not legally binding as a binding interpretation can only be made by the EU court.

The guides are developed by Danish Technological Institute and Viegand Maagøe consultants, Denmark.

March 2014

Guide to ecodesign and energy labelling requirements for oil- or gas-fired boilers

Contents

Summary	2
Which products shall comply with the requirements?	4
What are the requirements for energy labelling?	5
What are the requirements for ecodesign?	9
What are the requirements for documentations?	11
Where can I find information?	13

Are you a manufacturer or importer of oil- or gas-fired boilers?

Please be aware. There are requirements for energy efficiency, NO_x emissions and energy labelling of oil- or gas-fired boilers.

Oil- and gas-fired boilers providing heat to a water-based central heating system must meet the ecodesign requirements. This means that the product is designed in order to meet e.g. minimum energy efficiency requirements.

Oil- and gas-fired boilers must also be energy labelled.

Which products?

The Ecodesign Regulation applies to:

- Oil- and gas-fired boilers for space heating with a rated output up to and including 400 kW
- Oil- and gas-fired boilers for combined space and water heating with a rated output up to and including 400 kW

The Energy Labelling Regulation applies to:

- Oil- and gas-fired boilers for space heating with a rated output up to and including 70 kW
- Oil- and gas-fired boilers for combined space and water heating with a rated output up to and including 70 kW

Other products for space and water heating are also covered by the Ecodesign and Energy labelling Regulations.

When?

The requirements for energy labelling and ecodesign both apply from 26th September 2015.

The ecodesign requirements for oil-and gas-fired boilers include:

- From 26 September 2015 requirements for seasonal space heating energy efficiency for boilers with a rated output up to and including 70 kW
- From 26 September 2015 requirements for useful efficiency at 100 % and 30 % of the rated output of boilers with a rated output from 70 kW up to and including 400 kW
- From 26 September 2015 requirements for water heating energy efficiency for combination boilers. The requirements will be tightened from 26 September 2017
- From 26 September 2018 emission limits for nitrogen oxides (NO_x) in terms of nitrogen dioxide

- From 26 September 2015 requirements for information with regard to the properties of oil-and gas-fired boilers for space heating and combined space and water heating

The energy labelling requirements for oil- and gas-fired boilers include:

- Provision of printed EU energy label and product fiche from 26th September 2015
- Information on the energy class in advertisements and in technical promotion material from 26th September 2015
- Making electronic versions of the EU energy label and product fiche available to dealers from 26th September 2015 for new products placed on the market
- Display of the energy label and product fiche when the products are offered for sale through the internet

Who?

You have the responsibility of ensuring and documenting compliance with the requirements, if you are:

- a manufacturer in the EEA that produces oil- or gas-fired boilers to be placed on the market in the EEA
- an importer of oil- or gas-fired boilers from a country outside of EEA to be placed on the market in the EE.
- an authorised representative in the EEA for a manufacturer that is situated in a country outside of EEA

The above mentioned responsible parties are hereafter referred to as suppliers.

The EEA (European Economic Area) includes the EU member states and the EFTA countries.

Why?

The oil-and gas-fired boilers account for a large share of the energy consumption in the European households. Consequently EU has decided to reduce the energy consumption for oil-and gas-fired boilers by introducing requirements for energy efficiency and by introducing energy labelling with new energy classes.

Where can I find more information?

Find relevant regulations on the last page of this guide, or read more about ecodesign and energy labelling on www.ens.dk/energikrav

Disclaimer

This guide presents the contents of the Regulations and is addressed to manufacturers, importers and others interested. The guide is not a substitution for the Regulations, in any case of doubt, the Regulations are applicable. This guide is not legally binding as a binding interpretation can only be made by the EU court.

Acknowledgement

This guide is financed by the Norwegian Water Resource and Energy Directorate (NVE).

Which products must comply with the requirements?

Ecodesign requirements for oil and gas boilers with a rated output ≤ 400 kW will come into force. This also applies if the boiler is part of a package together with other products for space or water heating. The requirements apply even for boilers fired with other liquid fossil fuels than oil such as kerosene.

For boilers is distinguished between heat generators and heater housings. A heat generator is the part of a boiler, that produces heat from burning oil or gas (burner) and the heater housing is the part designed to be equipped with a heat generators (boiler body). A heat generator designed for a heater and a heater housing to be equipped with such a heat generator shall be also considered a heater

The requirements described in these guidelines do not apply to:

- Boilers specifically designed for using gaseous or liquid fuels predominantly produced from biomass
- Boilers within the scope of Directive 2010/75/EU of the European Parliament and of the Council about industrial emissions
- Boilers using solid fuels
- Boiler generating heat only for the purpose of providing hot drinking or sanitary water. Instead, they are covered by the requirements for water heaters
- Boilers for heating and distributing gaseous heat transfer media such as vapour or air
- Boilers designed for heaters and heater housings to be equipped with such heat generators placed on the market before 1 January 2018 to replace identical heat generators and identical heater housings. The replacement product or its packaging must clearly indicate the heater for which it is intended

The requirements pay particular attention to the boilers designed to be connected to a flue shared between multiple dwellings, the so-called B1-boilers.

The requirements for energy labelling of oil-and gas-fired boilers only apply to boilers with a rated output ≤ 70 kW.

A distinction is made between boilers for space heating and combination boilers. For the combination boilers apply that besides providing space heating, they must also be designed for providing hot water and for connection to an external water supply. There are additional requirements for ecodesign and energy labelling of combination boilers.

Figure 1 outlines three different types of boiler systems: a) is a boiler exclusively for space heating, b) is also characterized as a space heating boiler as it is not capable of providing domestic hot water or being connected to an external water supply, c) is a combination boiler. For hot water storages tanks there are separate requirements for ecodesign and energy labelling, see 'Guide to ecodesign and energy labelling requirements of hot water storage tanks'.

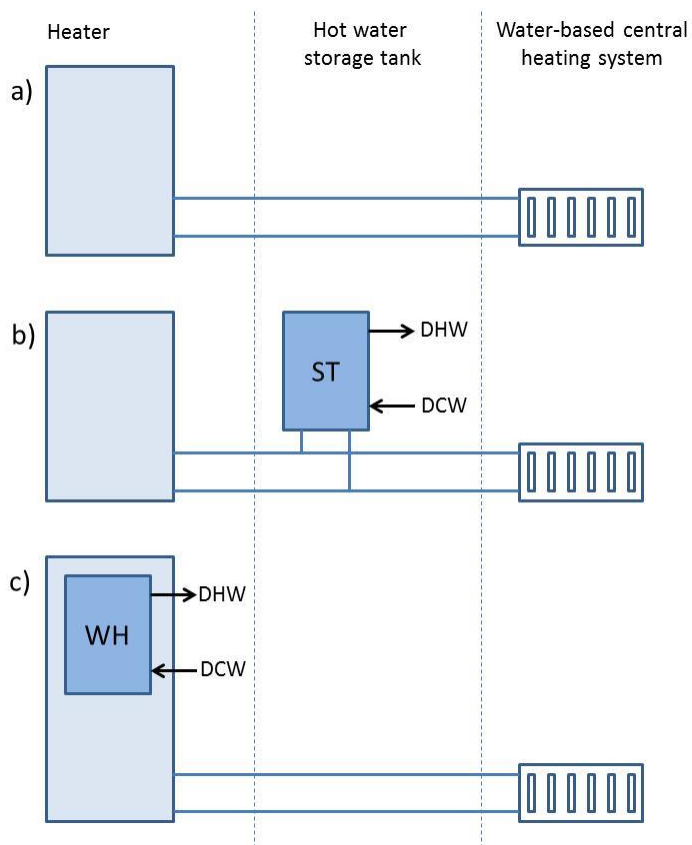

Figure 1: Different types of boiler systems

Basically, space heating boilers and combination boilers are assumed not to be equipped with temperature controls and solar devices. The requirements for ecodesign and energy labelling are based on such individual boilers. However, there are also requirements for energy labelling of packages consisting of boilers combined with temperature controllers and/or solar devices. ‘Guide to energy labelling requirements of packages of space heaters/combination heaters, temperature controls and solar devices’ describes the requirements.

What are the requirements for energy labelling?

From 26th September 2015, oil- and gas-fired boilers must be labelled with the EU energy label. The label is identical in all the EU/EEA countries and includes pictograms instead of text so that the label is easy to understand in all the countries.

The label has the recognizable red and green arrows and the A-G scale is expanded with the energy classes A⁺, A⁺⁺ and A⁺⁺⁺.

It is the responsibility of the boiler supplier to provide the energy label together with the boiler.

Energy efficiency classes on the label

The label for boilers for space heating includes one single scale, and energy classes will be introduced in two steps according to the schedule in Table 1. From 26 September 2015 an energy label with energy classes from A⁺⁺ to G is required, and from September 2019 a label with energy classes A⁺⁺⁺ to D is required.

For combination boilers the label includes two scales. One of the scales is identical with the label for boilers used for space heating, while the other scale covers water heating efficiency and has a different scale of energy classes, as shown in Table 1. From 26 September 2015 energy classes from A to G must be used for water heating efficiency and from 26 September 2019 energy classes from A⁺ to F apply.

Boiler function	Energy classes	Energy label from
Space heating	A ⁺⁺ - G	26 September 2015
Space heating	A ⁺⁺⁺ - D	26 September 2019
Water heating	A – G	26 September 2015
Water heating	A ⁺ - F	26 September 2019

Table 1: Plan for the introduction of energy classes

Determination of the energy classes

The label for space heating is based on the seasonal space heating energy efficiency (η_s) which is an expression for the delivered heat in relation to the energy input during the heating season. The seasonal space heating energy efficiency is based on an average European climate similar to the climate of Strasbourg.

For oil- and gas-fired boilers the seasonal space heating energy efficiency is calculated based on results from tests of the boiler's useful efficiency at a rated load and 30 % part load. The calculation also includes corrections for temperature control, boiler electricity consumption (burning, ignition, etc.) standby heat losses and pilot flame (if applicable).

The energy label for water heating is based on water heating energy efficiency (η_{WH}) which is an expression of the supplied hot water in relation to energy input for a given consumption load profile.

The load profiles are adjusted to various water consumption needs and are described by size categories ranging from XS to XXL. The load profiles are described by a number of 'water draw-off's' and the requirements for water temperature and flow are spread over a day from 7:00 a.m. to 22:00 p.m. with defined intervals.

Water heating energy efficiency is calculated on the basis of the test of the combination boiler at a load profile that fits the boiler's hot water production capacity.

All energy input from oil and gas is calculated in relation to the gross calorific value and the power consumption is multiplied by a conversion coefficient $CC = 2.5$, reflecting the power production's estimated average efficiency of 40 % in the EU.

Gross calorific value versus net calorific value

Traditionally in Europe, energy input from fuels has been related to net calorific value. By changing to gross calorific value, efficiencies in general will seem less as the gross calorific value is approx. 6 % and 10 % higher for oil and gas respectively. Example: An oil-fired boiler with an efficiency of 93 % related to the net calorific value will have an efficiency of 88 % when related to the gross calorific value.

Methods of measurement and calculation of the various factors are described in the Regulation EU No 811/2013, Annex VII.

Be aware:

It is the actual measurement results without addition of tolerances that must be used for declaration of the energy efficiency class and other required declarable values.

Information on the energy label

Labels must include information on the boiler's energy class, rated output and noise. In addition, for combination boilers, information on water heating energy class, load profile and ability to operate only during off-peak operation must be declared. Off-peak operation is if the energy input is provided outside the 'water draw-offs' period, i.e. between 22:00 p.m. and 7:00 a.m.

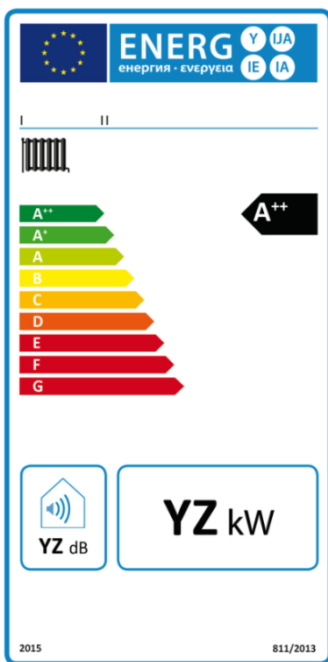

I, II
III
IV
VI, V

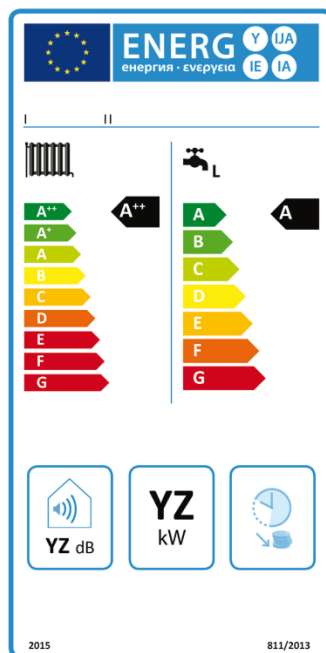

I, II
III
IV
VI, V, VII

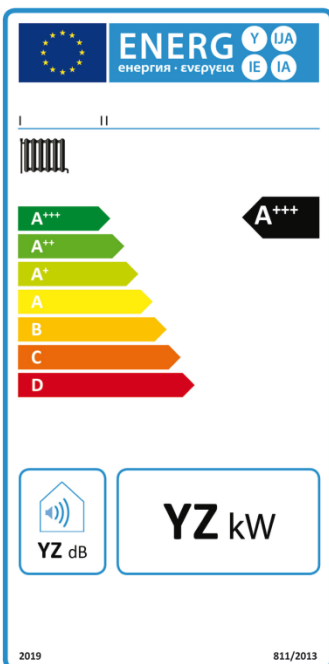

I, II
III
IV
VI, V

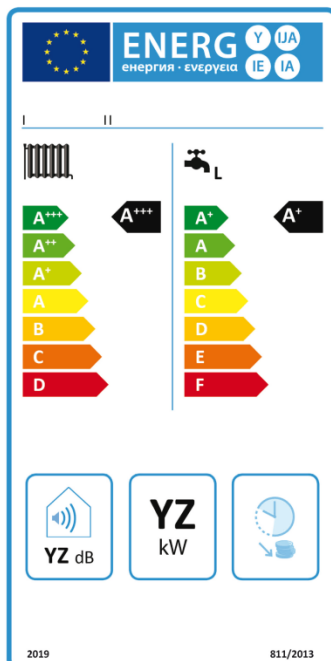

I, II
III
IV
VI, V, VII

Energy classes

For space heating the connection between energy class and seasonal space heating energy efficiency is as shown in Table 2.

Seasonal space heating energy efficiency class	Seasonal space heating energy efficiency η_s in %
A ⁺⁺⁺	$\eta_s \geq 150$
A ⁺⁺	$125 \leq \eta_s < 150$
A ⁺	$98 \leq \eta_s < 125$
A	$90 \leq \eta_s < 98$
B	$82 \leq \eta_s < 90$
C	$75 \leq \eta_s < 82$
D	$36 \leq \eta_s < 75$
E	$34 \leq \eta_s < 36$
F	$30 \leq \eta_s < 34$
G	$\eta_s < 30$

Table 2: Energy classes for space heating

For water heating the connection between energy class for a given load profile and energy efficiency is as shown in Table 3.

	3XS	XXS	XS	S	M	L	XL	XXL
A ⁺⁺⁺	$\eta_{wh} \geq 62$	$\eta_{wh} \geq 62$	$\eta_{wh} \geq 69$	$\eta_{wh} \geq 90$	$\eta_{wh} \geq 163$	$\eta_{wh} \geq 188$	$\eta_{wh} \geq 200$	$\eta_{wh} \geq 213$
A ⁺⁺	$53 \leq \eta_{wh} < 62$	$53 \leq \eta_{wh} < 62$	$61 \leq \eta_{wh} < 69$	$72 \leq \eta_{wh} < 90$	$130 \leq \eta_{wh} < 163$	$150 \leq \eta_{wh} < 188$	$160 \leq \eta_{wh} < 200$	$170 \leq \eta_{wh} < 213$
A ⁺	$44 \leq \eta_{wh} < 53$	$44 \leq \eta_{wh} < 53$	$53 \leq \eta_{wh} < 61$	$55 \leq \eta_{wh} < 72$	$100 \leq \eta_{wh} < 130$	$115 \leq \eta_{wh} < 150$	$123 \leq \eta_{wh} < 160$	$131 \leq \eta_{wh} < 170$
A	$35 \leq \eta_{wh} < 44$	$35 \leq \eta_{wh} < 44$	$38 \leq \eta_{wh} < 53$	$38 \leq \eta_{wh} < 55$	$65 \leq \eta_{wh} < 100$	$75 \leq \eta_{wh} < 115$	$80 \leq \eta_{wh} < 123$	$85 \leq \eta_{wh} < 131$
B	$32 \leq \eta_{wh} < 35$	$32 \leq \eta_{wh} < 35$	$35 \leq \eta_{wh} < 38$	$35 \leq \eta_{wh} < 38$	$39 \leq \eta_{wh} < 65$	$50 \leq \eta_{wh} < 75$	$55 \leq \eta_{wh} < 80$	$60 \leq \eta_{wh} < 85$
C	$29 \leq \eta_{wh} < 32$	$29 \leq \eta_{wh} < 32$	$32 \leq \eta_{wh} < 35$	$32 \leq \eta_{wh} < 35$	$36 \leq \eta_{wh} < 39$	$37 \leq \eta_{wh} < 50$	$38 \leq \eta_{wh} < 55$	$40 \leq \eta_{wh} < 60$
D	$26 \leq \eta_{wh} < 29$	$26 \leq \eta_{wh} < 29$	$29 \leq \eta_{wh} < 32$	$29 \leq \eta_{wh} < 32$	$33 \leq \eta_{wh} < 36$	$34 \leq \eta_{wh} < 37$	$35 \leq \eta_{wh} < 38$	$36 \leq \eta_{wh} < 40$
E	$22 \leq \eta_{wh} < 26$	$23 \leq \eta_{wh} < 26$	$26 \leq \eta_{wh} < 29$	$26 \leq \eta_{wh} < 29$	$30 \leq \eta_{wh} < 33$	$30 \leq \eta_{wh} < 34$	$30 \leq \eta_{wh} < 35$	$32 \leq \eta_{wh} < 36$
F	$19 \leq \eta_{wh} < 22$	$20 \leq \eta_{wh} < 23$	$23 \leq \eta_{wh} < 26$	$23 \leq \eta_{wh} < 26$	$27 \leq \eta_{wh} < 30$	$27 \leq \eta_{wh} < 30$	$27 \leq \eta_{wh} < 30$	$28 \leq \eta_{wh} < 32$
G	$\eta_{wh} < 19$	$\eta_{wh} < 20$	$\eta_{wh} < 23$	$\eta_{wh} < 23$	$\eta_{wh} < 27$	$\eta_{wh} < 27$	$\eta_{wh} < 27$	$\eta_{wh} < 28$

Table 3: Energy classes for water heating

What are the requirements for ecodesign?

From 26 September 2015 oil- and gas-fired boilers must meet the minimum requirements for seasonal space heating energy efficiency/useful efficiency for space heating. Besides, combination boilers must meet the minimum requirements for water heating efficiency. From 26 September 2018 the maximum requirements for NO_x emissions must also be met.

The minimum requirements for seasonal space heating energy efficiency/useful efficiency, water heating efficiency and NO_x emissions are related to gross calorific value - just as in connection with the energy labelling.

Requirements for seasonal space heating energy efficiency

Oil- and gas-fired boilers for space heating and combination boilers with a rated output ≤ 70 kW must meet the requirements for seasonal space heating energy efficiency by space heating in Table 4:

Boiler type	Requirements for seasonal space heating energy efficiency
Space heating boiler	≥ 86 %
Combination boiler	≥ 86 %
Exemption: Type B1 boiler with a rated output ≤ 10 kW	≥ 75 %
Exemption: Type B1 combination boiler with a rated output ≤ 30 kW	≥ 75 %

Table 4 Requirements for seasonal space heating energy efficiency. The seasonal space heating energy efficiency should be at least as shown in the table

The requirements imply that all oil- and gas-fired boilers must be condensing with the exemption of a special type, B1, which is designed to be connected to a flue shared between multiple dwellings. This exemption is limited to a maximum rated output for the boiler type in question as specified in table 4.

Requirements for useful efficiency

Oil and gas boilers with a rated output > 70 kW and ≤ 400 kW must meet the requirements of a useful efficiency at full load of at least 86 % and a useful efficiency at 30 % part load of at least 94 %. These requirements result in condensing boilers.

Requirements for water heating efficiency

The minimum requirements for water heating energy efficiency for combination boilers are introduced in two steps. Table 5 shows the minimum requirements from 26 September 2015 and the tightened requirements from 26 September 2017.

Declared load profile	3XS	XXS	XS	S	M	L	XL	XXL	3XL	4XL
Water heating energy efficiency	22 %	23 %	26 %	26 %	30 %	30 %	30 %	32 %	32 %	32 %

Declared load profile	3XS	XXS	XS	S	M	L	XL	XXL	3XL	4XL
Water heating energy efficiency	32 %	32 %	32 %	32 %	36 %	37 %	38 %	60 %	64 %	64 %

Table 5 Requirements for water heating energy efficiency. The water heating energy efficiency shall be at least as shown in the table

Requirements for NO_x emissions

From 26 September 2018 NO_x emissions expressed as NO₂ and related to fuel consumption on the basis of gross calorific value must not exceed the values in Table 6.

Boiler type	Fuel	NO _x emissions
Space heating boiler	Gaseous	≤ 56 mg/kWh
Combination boiler	Gaseous	≤ 56 mg/kWh
Space heating boiler	Liquid	≤ 120 mg/kWh
Combination boiler	Liquid	≤ 120 mg/kWh

Table 6 Requirements for NO_x emissions. NO_x emissions must not exceed the values in the table

Miscellaneous

The measurement and calculation methods are identical to the ones used for energy labelling.

In addition, a heat generator designed for a boiler and a boiler housing to be equipped with such heat generators must be tested with an appropriate boiler housing and heat generator, respectively.

What are the requirements for information and documentation?

Energy labelling

Energy label and product fiche

All oil- and gas-fired boilers for space heating or combination boilers placed on the market from 26 September 2015 must be provided with a printed label and a product fiche. A product fiche may include several models of boilers for space heating from the same supplier, see the guidelines for product fiches in the Regulation of energy labelling, Annex IV.

Furthermore, electronic versions of the energy label and the product fiche must be made available to dealers for new products placed on the market. The layout of the electronic energy label must be identical with the printed label and the electronic versions of the label and the fiche must include the same information as the printed versions.

Information in technical promotional material and in advertisements

Relevant technical promotion material and advertisements for boilers shall include information on the energy class of the boiler. Further information is available in the Regulation 811/2013/EU, Article 3 and 4.

Labelling on the internet

The electronic energy label and product fiche must be shown on the display in proximity to the price when heat pumps and electric boilers are offered for sale or hire through the internet. The label and the product fiche may be shown using a “nested display”.

Ecodesign

CE marking and EC declaration of conformity

Boilers covered by the ecodesign requirements must be CE marked when they are placed on the EEA market.

Furthermore, an EC declaration of conformity must be made available by the supplier. In the EC declaration of conformity, the manufacturer or its authorised representative in the EEA must document and guarantee that their boilers comply with all relevant EU regulations. Consequently, the reference number of the Ecodesign Regulation 813/2013/EU must be mentioned in the declaration of conformity.

Find requirement for the contents of EC declaration of conformity in the Ecodesign Directive 2009/125/EC Annex VI.

Ecodesign and energy labelling

Technical documentation

The supplier is responsible for making sure that the boiler has a technical documentation when placing it on the EEA market. The technical documentation must show that the boiler is constructed in conformity with the ecodesign requirements and that the energy labelling of the boiler is correct. The technical documentation must be compiled by the manufacturer.

For boilers, you can see the requirements for technical documentation and information to be made available on the manufacturer's website in Regulation 813/2013/EU Annex II, point 5 and in Regulation 811/2013/EU Annex V.

The market surveillance authorities of EEA countries may request the technical documentation, and you must provide it within a maximum of ten days after receiving the request.

The documentation relating to ecodesign requirements must be stored for a period of ten years after the last model of that product has been manufactured. In the case of energy labelling requirements the documentation must be stored in five years.

Measurement methods

Reliable, accurate and reproducible measurement methods based on generally accepted measurement techniques must be used. A reproducible measurement method means that the measurements can be repeated with the same result. The technical documentation must be based on a third party testing of oil- and gas-fired boilers as the relevant clauses about this in the Boiler Directive 92/42/EC are retained. In all other respects Regulation EU No 813/2013 replaces the Boiler Directive.

The measurements must always be carried out in accordance with guidelines of the Regulations.

Where can I find information?

Danish Energy Agency's homepage www.ens.dk/energikrav contains more information about policies, new requirements in regulations, guidance, contact information and links to relevant legislation.

Legislations

COMMISSION REGULATION (EU) No 813/2013 of 2 August 2013 implementing Directive 2009/125/EC of the European Parliament and of the Council with regard to ecodesign requirements for space heaters and combination heaters.

DIRECTIVE 2009/125/EC OF THE EUROPEAN PARLIAMENT AND OF THE COUNCIL of 21 October 2009 establishing a framework for the setting of ecodesign requirements for energy-related products (recast).

COMMISSION DELEGATED REGULATION (EU) No 811/2013 of 18 February 2013 supplementing Directive 2010/30/EU of the European Parliament and of the Council with regard to the energy labelling of space heaters, combination heaters, packages of space heater, temperature control and solar device and packages of combination heater, temperature control and solar device.

DIRECTIVE 2010/30/EU OF THE EUROPEAN PARLIAMENT AND OF THE COUNCIL of 19 May 2010 on the indication by labelling and standard product information of the consumption of energy and other resources by energy-related products (recast)

Danish legislations with regard to ecodesign

The ecodesign directive is implemented by the following Danish legislations:

- Lovbekendtgørelse om miljøvenligt design af energirelaterede produkter, nr. 1068 af 15. september 2010
- Bekendtgørelse om miljøvenligt design af energirelaterede produkter, nr. 1274 af 19. november 2010 (only available in Danish)

Danish legislations with regard to energy labelling

The energy labelling directive is implemented by the following Danish legislations:

- Lov om energimærkning af energirelaterede produkter, nr. 455 af 18. maj 2011
- Bekendtgørelse om energimærkning af energirelaterede produkter, nr. 1026 af 18. maj 2011 (only available in Danish)

Where can I find help and guidance?

You can have your questions answered and help to comply with the requirements by contacting the Secretariat for Ecodesign and Energy Labelling of Products

Telephone: +45 43 30 50 20

Monday to Thursday 9:00 - 16:00

Friday 9:00 - 15:30

E-mail: sekretariat@eco-energimaerke.dk

Danish Energy Agency
Amaliegade 44
DK 1256 Copenhagen K

www.ens.dk

Telephone: +45 33 92 67 00

E-mail: ens@ens.dk



More about ecodesign and energy labelling:

www.ens.dk/energikrav

E-mail: ecodesign@ens.dk