



Danish Energy Agency



Ministry
of Energy
of Ukraine

Urgent Technology Catalogue

For the Ukrainian Power Sector

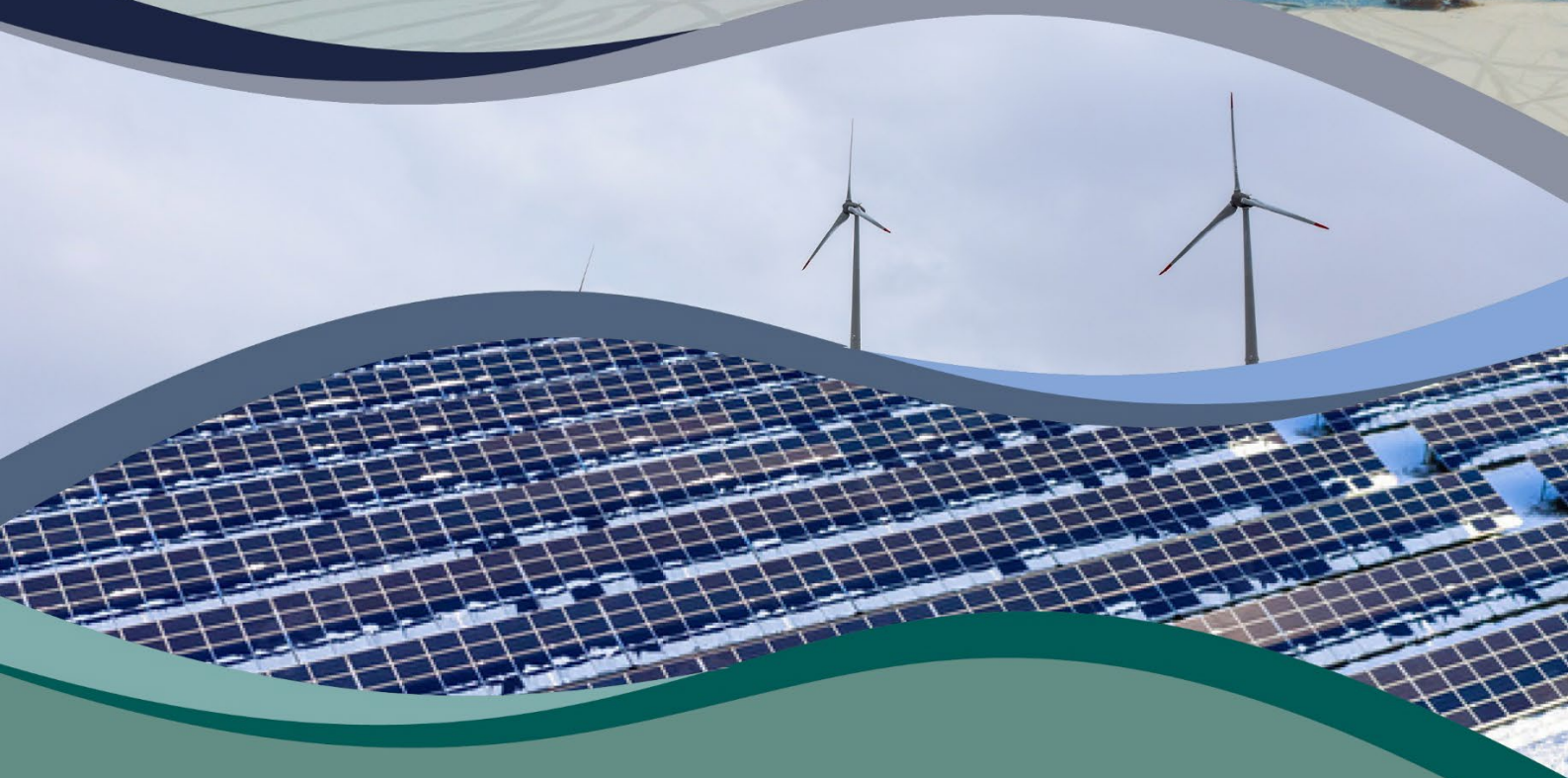

Edition: January 2024



Danish Energy Agency



Ministry
of Energy
of Ukraine



Ea Energy Analyses



Institute for
Economics and
Forecasting of the
National Academy
of Sciences of
Ukraine

Edition: January 2024

Table of contents

4	Introduction
8	Methodology
22	Evaluation of chosen technologies
24	Gas power plants
34	Photovoltaics
49	Onshore Wind
64	Batteries
72	Biogas plant
75	Coal power plants, Repair and lifetime extension (replacement of equipment)
86	Biomass cogeneration technologies
100	Hydropower
112	References
113	Appendix A: Methodology
118	Appendix B: LCOE calculations
119	Appendix C: Cross cutting issues
122	Appendix D: Methodology for determining PV resource potentials in Ukraine
123	Appendix E: Methodology for determining wind resource potentials in Ukraine
124	Appendix F: Data sheets
125	Appendix G: Local consideration
128	List of abbreviations

List of Figures

- 15 Figure 1: Example I. Visualization of criteria and general score
- 16 Figure 2: Technology Summaries, of best technologies in each category (Gas engines, rooftop PVs household, commercial and industrial, Onshore wind turbines, farms >20MW, Coal power plants retrofitting, Batteries Li-ion community scale, biomass CHPsmall wood pellets, Hydro RoR micro
- 20 Figure 3: Assessment of the Implementing speed measured in weeks
- 20 Figure 4: Overview of resilience assessment all sub-technologies, the parameters are weighted
- 21 Figure 5: LCOE for wintertime production over 2 years
- 22 Figure 6: LCOE total production over the lifetime
- 29 Figure 7: Process diagram of a SCGT[1]
- 30 Figure 8: Gas engine cogeneration unit
- 39 Figure 9: Expected PV generation (MWh per MW installed capacity)) in different regions of Ukraine. An annual production of 1200 MWh/MW corresponds to a capacity factor of 14%. The maps are set up calculating the generalized power generation from photovoltaics, in the different Ukrainian regions, Global Solar Atlas covering the period between 1994-2018 was used
- 46 Figure 10: Expected wintertime PV generation (MWh per MW installed capacity) in different regions of Ukraine. A wintertime production of 350 MWh/MW corresponds to app. 30 % of the annual production and a capacity factor of 8%. The maps are set up calculating the generalized power generation from photovoltaics, in the different Ukrainian regions, Global Solar Atlas covering the period between 1994-2018 was used
- 50 Figure 11: Expected annual PV generation (MWh per MW installed capacity) in different regions of Ukraine. An annual production of 1200 MWh/MW corresponds to a capacity factor of 14%. Buffer zones of 100km and 280km was applied from Russian controlled areas and Belarus, accounting for the longest range of Russian artillery and CRBMs (close range ballistic missiles). The maps are set up calculating the generalized power generation from photovoltaics, in the different Ukrainian regions, Global Solar Atlas

- covering the period between 1994-2018 was used
- 50** Figure 12: Expected wintertime PV generation (MWh per MW installed capacity) in different regions of Ukraine. And wintertime production of 350 MWh/MW corresponds to app. 30 % of the production and a capacity factor of 8%. Buffer zones of 100km and 280km was applied from Russian controlled areas and Belarus, accounting for the longest range of Russian artillery and CRBMs (close range ballistic missiles). The maps are set up calculating the generalized power generation from photovoltaics, in the different Ukrainian regions, Global Solar Atlas covering the period between 1994-2018 was used
- 54** Figure 13: General wind turbine technology and electrical system
- 54** Figure 14: Four Vestas 3 MW wind turbines
- 55** Figure 15: Wind resource chart, expected annual wind turbine generation (MWh per MW installed capacity) in different regions of Ukraine. An annual production of 3500 MWh/MW corresponds to a capacity factor of 40%
- 58** Figure 16: Expected Wind turbine generation (MWh per MW installed capacity) in different regions of Ukraine during wintertime (which in this context is defined as October-March, 4374 hours in total)
- 62** Figure 17: Expected wintertime wind turbine generation (MWh per MW installed capacity) in different regions of Ukraine during wintertime (which in this context is defined as October-March, 4374 hours in total) along with an indication of the range of Russian artillery and close-range ballistic missiles
- 63** Figure 18: ANTARIS 2.5 kW household wind turbines
- 69** Figure 19: Services LIB can provide to different stakeholder groups [2]
- 70** Figure 20: Schematic illustration of a grid-scale battery storage system
- 77** Figure 21: Schematic diagram for a biogas CHP system [8]
- 81** Figure 22: Sketch of the main elements of a large coal fired CHP plant
- 81** Figure 23: Illustrates the proportion of the investment cost, when a coal-fired power plant's lifetime is extended. [13]
- 82** Figure 24: Illustrates the proportion of the investment cost, when a coal-fired power plant's component category is replaced with new components. The proportion should be multiplied by the cost of a new coal-fired power plant
- 91** Figure 25: Main systems of a CHP facility, example waste to energy CHP facility [Technology Data – Energy Plants for Electricity and District heating generation, 2016, Danish Energy Agency]
- 105** Figure 26: Run-of-river hydropower plant schematics (ref. 2, 3)
- 105** Figure 27: Reservoir hydropower plant schematic (ref. 2, 3)
- 106** Figure 28: Cascading System principle (ref. 4)
- 106** Figure 29: Pumped Hydro Storage power plant (ref. xx)
- 107** Figure 30: Hydro Power – definition of net and gross head (ref. 5)
- 107** Figure 31: Hydropower turbine application chart (ref. 5)
- 108** Figure 32: Total inst. cost, capacity factor, LCOE for hydropower (world) (ref. 6)

- 114** Figure 33: Dniester Hydro Power Complex, ref. [21]
- 115** Figure 34: Dnieper river dams and cascading system ref. [21]s
- 130** Figure 35: The Merefya solar park in Kharkiv region partially damaged by Russian attacks
Photo by: Solar Generation
- 130** Figure 36: Solar Park in Kharkiv partially damaged by Russian attacks.
Photo by: Solar Energy Association of Ukraine

List of Tables

- 13** Table 1: Overview over the evaluation parameters and definition of the levels, column “Criteria” indicates which of the four principal criteria the parameter is contributing to is indicated by the letter (W, Q, R or C) in the. W: Winter Impact, Q: Implementation speed (Quick), R: Resilience in operation in UA context and C: Cost of generating the electricity (also referred to Levelized cost of electricity)
- 14** Table 2: Overview of which parameters contribute to which criteria and visualizing of the ratings, the more icons the better rating
- 18** Table 3: Criteria evaluation matrix on sub-technology level, for the implementation speed green indicate that the technology could be in operation within less than 0,5 year, yellow indicate: could be in operation within 1-1,5 year and red that it would take more than 2 years to bring it in operation
- 22** Table 4: Parameter evaluation matrix
- 28** Table 5: Gas power plants – Overall criteria evaluation matrix
- 29** Table 6: Gas turbines, simple cycle – criteria evaluation matrix
- 31** Table 7: Gas engines – criteria evaluation matrix
- 32** Table 8: Gas Power – parameters evaluation matrix. The LCOE unit is [€/MWh]
- 38** Table 9: Photovoltaics – Overall criteria evaluation matrix
- 40** Table 10: PV residential rooftop – criteria evaluation matrix
- 41** Table 11: PV commercial, industrial, and public rooftop – criteria evaluation matrix
- 42** Table 12: PV utility-scale – criteria evaluation matrix
- 44** Table 13: PV utility-scale floating – criteria evaluation matrix
- 45** Table 14: Photovoltaic technologies – parameter evaluation matrix. The LCOE unit is [€/MWh].

- 53** Table 15: Wind Power – Overall criteria evaluation matrix
- 55** Table 16: Wind Power – criteria evaluation matrix for Large-scale onshore wind farm (20-100 MW)
- 56** Table 17: Wind Power – criteria evaluation matrix for Cluster of onshore wind turbines (5-20 MW)
- 56** Table 18: Wind Power – criteria evaluation matrix for Used wind turbines for a large-scale onshore wind farm (20-100 MW)
- 57** Table 19: Wind Power – parameters evaluation matrix for onshore (MW scale). The LCOE unit is [€/MWh]
- 63** Table 20: Wind Power – criteria evaluation matrix for Household wind turbines
- 64** Table 21: Wind Power – parameters evaluation matrix for onshore household turbines (kW scale). The LCOE unit is [€/MWh]
- 71** Table 22: LIB utility scale – criteria evaluation matrix
- 72** Table 23: LIB community scale- criteria evaluation for community scale LIB
- 73** Table 24: Parameters evaluation matrix for batteries. The LCOE unit is [€/MWh]
- 79** Table 25: Coal power – overall criteria evaluation matrix
- 82** Table 26: Coal Power Plants, Lifetime Extension – criteria evaluation matrix
- 84** Table 27: Coal Power Plants, Lifetime Extension – parameters evaluation matrix. The LCOE unit is [€/MWh]
- 92** Table 28: Criteria evaluation matrix for back pressure CHPs using wood pellets, -chips and straw as fuels
- 93** Table 29: Parameter evaluation matrix of biomass CHP medium scale back pressure plants. The LCOE unit is [€/MWh]
- 97** Table 30: Criteria evaluation matrix for organic Rankine cycle plants, using wood pellets, wood chips and straw as fuel
- 98** Table 31: Parameter evaluation matrix of biomass-fired ORC CHP plants. The LCOE unit is [€/MWh]
- 104** Table 32:Hydropower – overall criteria matrix for hydropower technologies
- 106** Table 33: Classification of hydropower plants based on capacity size
- 108** Table 34: List of hydro power plants in UA HPP: Hydro Power Plant with dam; PHS: Pump Hydro Storage Power Plant; RoR: Run of River (without a dam)- variable like wind and solar
- 109** Table 35: Criteria evaluation matrix of hydro power plants
- 111** Table 36: Parameter evaluation matrix of hydro power plants. The LCOE unit is [€/MWh]
- 125** Table 37: Transformers categories and their key parameters
- 126** Table 38: Estimated delivery time per transformer’s category

INTRODUCTION

Background / Context

Previous technology and energy modelling activities that were conducted under the Ukraine-Denmark Energy Partnership (UDEPP), have shown that different stakeholders use varying data and assumptions regarding current and future energy technologies in Ukraine. This has the potential to cause discrepancies between different studies, and lead to differing or incompatible conclusions and recommendations in strategic documents. Most importantly, the full-scale Russian invasion of Ukraine has resulted in extensive damage done to the country's energy infrastructure.

Hence, under the Ukraine-Denmark Energy Partnership Programme (UDEPP), Ministry of Energy of Ukraine (MoE) have requested a fast development of a short-term and urgent energy technology catalogue for selected decentralized power generation capacities relevant for Ukraine that could be implemented quickly and facilitate enhanced security of distributed power supply for winter seasons, ideally already 2023-24, but certainly 2024-25.

The aim is that the catalogue will help local, regional, and national stakeholders, developers,

companies, and others, to prioritize and select relevant power production technologies, in outlining framework and determine priorities for technology choices and attracting investments and donor assistance in the restoration and development of the power system of Ukraine in the coming winter seasons.

This urgent winterization technology catalogue will help build consensus on power generating technology costs and technical parameters between stakeholders in Ukraine, presenting validated and agreed data for power generating technology in these four newly developed dimensions:

- Power capacity in wintertime
- Implementing speed
- Technology resilience
- Levelized cost of electricity (2 years vs full lifetime)

In the longer term, a full-scale energy technology catalogue for Ukraine will be developed.

Both short-term and long-term technology catalogues, and corresponding technology specific performance parameters and costs, will provide a common and key foundation for energy and power sector planning and implementation activities.

In view of its acute purpose, to be ready for the upcoming winters and considering the short time available for the development and finalization of the first version of the catalogue, it has been necessary to narrow down the number of technologies as well as the range of details normally found in technology catalogues. This decision has been made in agreement with MoE. Hence, this urgent catalogue only includes data on carefully selected technologies and data for the present situation only. Time series data on the past and the future development of technologies over the decades is not included, as they would be in ordinary energy technology catalogues.

The purpose of this urgent technology catalogue

This urgent technology catalogue aims to support decision making at local, regional, and national level across different stakeholders, donors, developers, companies, and authorities.

Therefore, the main focus of this technology catalogue for decentralised power generation technologies is to map their potential for supplying electricity in the current Ukrainian context for winter seasons 2023-24/2024-25 which could be implemented to facilitate enhanced security of power supply.

Thus, technologies included in this technology catalogue are evaluated according to the following four principal criteria:

Winter impact, defined as the share of yearly production that can be delivered at wintertime (October to March)

Possibility for bringing in operation within a short time frame (implementation speed).

This includes evaluation of (A) time for planning and regulation approvals, B) time for acquisition of the plant (component and materials) and C) Technical installation time.

The resilience of selected technologies. This involves an evaluation of how well the

technology performs at distribution system level, how well it could be camouflaged and sheltered, and the requirements (risks and skills) for keeping it in operation.

Levelized cost of electricity (LCOE) for electricity supply during the wintertime over a short lifetime (2 years). As background information, to evaluate the economics of the technology in a longer-term perspective, a LCOE for total electricity over the full lifetime is also shown.

Additionally, this urgent technology catalogue includes only technologies, which could perform well in relation to the above-mentioned four principal criteria. The requirement on suitability for distributed production implies for example that only technology types which are reasonable to operate with capacities less than 60 MW are included.

As a starting point, eight power generation technology types (listed in the section below) have been addressed. Through a screening process, a limited number of specific “sub-type-technologies” has been identified as relevant to evaluate in the current context in Ukraine. The screening of the eight generic technology types ended up in a list of 22 sub-technologies shown below.

The evaluation of the four principal criteria for the different technologies is supported by assessment of 14 mostly descriptive and qualitative parameters listed in Table 1. In Appendix A: Methodology these 14 parameters are discussed, elaborating on why they are relevant to include in the assessments in this urgent technology catalogue and on how the qualitative parameters can be assessed at a three-level scale (good, medium, bad).

Each technology chapter will also include a brief technology description of the specific technology as well as a data sheet focused on data under today’s conditions (e.g., 2024). The data sheets for the different technologies from the traditional Energy technology catalogue describing the technical and financial parameters can be found in Appendix F: Data sheets

Due to the short time frame available for the development of this catalogue, it will be continuously updated and still pending sub-technologies and documentation will be added in the next version.

Technologies included in the evaluation

The following technologies are assessed:

1. Gas power plants
 - a) Gas Turbines, simple cycle, natural gas
 - b) Gas engines, natural gas
 - c) Gas engines, biogas directly from a green field biogas plant
2. Photovoltaics (PV)
 - a) Rooftop PV on single family houses
 - b) Rooftop and ground mounted PV on public buildings (incl. hospitals) without batteries
 - b) 5.b) Rooftop and ground mounted PV on public buildings (incl. hospitals) with batteries
 - d) PV utility scale, ground mounted without batteries,
 - e) PV Utility scale, floating, e.g., on hydropower dams (here the hydro- dams can be regarded as storage, but are not included)
3. Wind turbines
 - a) Onshore wind turbines, farms 20 – 100 MW
 - b) Onshore wind turbines, farms 20 – 100 MW, used turbines.
 - c) Onshore wind, cluster of 3-5 turbines 3- 20 MW
 - d) Household (domestic) wind turbines 1-25 kW
4. Coal power plants, lifetime extension (replacement of plant's equipment)
 - a) Retrofitting existing plants, improving efficiency
5. Batteries - Lithium ion not small-scale BESS
 - a) Grid-scale batteries, (capacity app. 2 MW -150MW, energy storage 2MWh -500 MWh)
 - b) Community batteries (capacity app. 40-150 kW, energy storage app. 40- 600-kWh)

6. Biogas
- no specific sub-technologies have been identified during the screening, but a gas engine fueled by biogas is included as a part of gas power

7. Biomass cogeneration (CHP) technologies
 - a) Wood pellets medium, back pressure, 25 MWe
 - b) Wood pellets small Organic Rankine Cycle, 3 Mwe
 - c) Wood chips, medium, back pressure, 25 MWe
 - d) Wood chips, small Organic Rankine Cycle, 3 MWe
 - e) Straw/stalks/husk small Organic Rankine Cycle, 3 MWe
 - f) Straw/stalks/husk medium, back pressure, 25 Mwe

8. Hydro Power
 - a) Mini, Hydro Power, run of river
 - b) Micro, Hydro Power, run of river
 - c) Retrofit hydropower (dams) incl. pumped hydropower storage

The structure of the technology chapters of the urgent technology catalogue

The format of the technology chapters comprises an overview of each technology group, showcasing the overarching findings of the respective technology segment. This is then followed by a detailed evaluation of each sub-technology, encompassing:

1. Brief technology description
2. Criteria evaluation based on the four defined criteria
3. Parameter evaluation based on the fourteen defined parameters
4. Data sheet in Excel in appendix F.
5. Due to shared similarities between some of the technologies the order of the evaluation differs from one technology to another and some of the evaluation points are presented together for clusters of sub-technologies.

METHODOLOGY

The qualitative and quantitative parameters addressed in this urgent technology catalogue are based on the information gathered through semi-structured interviews with Ukrainian, Danish, and international energy experts and developers, in addition to Ukrainian authorities, associations, and organizations working in the energy sector and its supply chains have been consulted during the process.

Based on the outcomes of the interviews with developers and experts, the typical process for power plants' installation, expected bottlenecks, and realistic possibilities to speed up the implementation process under the current condition are described and analyzed according to the parameters.

In addition to the information obtained through interviews, data from the Danish Energy Technologies adjusted to the Ukrainian context, have been applied, along with evidence about wind and solar resources in Ukraine from public sources and information gathered from literature sources and websites of manufacturers.

Assessment of parameters and criteria

In general, the starting point for assessing the technologies is that it is new project, set up as greenfield projects. Thereby, there is made no prior project development or preparation of the of the place for the plants and the equipment used are new. Although, it could be positive for the implementation speed, if the project could build upon already conducted project development, e.g., projects that was in the process or maybe even approved before the war started, or if the plants are establishing in the same location and as a replacement for destroyed facilities or if used equipment was used. Unfortunately, identification of already developed projects and potential replacement projects have not been possible within the timeframe of this project.

In case any of the above-mentioned opportunity is included in the assessment of a technology it will be clearly stated.

An overview of the 14 parameters which are discussed and assessed in this technology catalogue is presented in Table 1. To make it

easier to distinguish between criteria and parameter, each parameter (P) is given a number e.g., P1, P2, P3, as presented in Table 1

A description of the 14 parameters is in Appendix A: Methodology. In the appendix is descriptions

of the reasons for addressing each parameter in this technology catalogue and how they influence the implementation of power generation projects in the current Ukrainian context. Following this, the three-level assessment scale specific to each of these parameters is described.

Parameters	Criteria	Evaluation levels:		
		Good	Medium	Bad
P1-Electricity production at wintertime	W	>75%	40%-75%	<40%
P2-Levelized Cost of Electricity (LCOE) short lifetime, winter production	C	low	Medium	high
P3-Levelized Cost of Electricity (LCOE) over lifetime		Low	Medium	high
P4-Distributed generation	R	<5 MW	5-20 MW	20-60 MW
P5-Regulation requirement in the project development process	Q	Quick and easy	In between	Lengthy
P6-Delivery time and availability of components and materials	Q	winter 2023/2024	winter 2024/2025	>2 years
P7-Requirements for logistics and transportation infrastructure	Q	low	Medium	high
P8-Technical installation time (after clearance)	Q	Short	Medium	Long
P9-Requirements for skilled staff in construction phase	Q	Low	Medium	High
P10-Grid balancing capacity	R	High	Medium	Low
P11-Requirements for electricity grid infrastructure	Q	Easy	Moderate	Challenging
P12-Requirements for skilled staff for operation and maintenance and for special spare parts	R	Low	Medium	High
P13-Possibility for camouflage and sheltering	R	High	Medium	Low
P14-Risk associated with fuel supply	R	Low	Medium	High

Table 1: Overview over the evaluation parameters and definition of the levels, column “Criteria” indicates which of the four principal criteria the parameter is contributing to is indicated by the letter (W, Q, R or C) in the. W: Winter Impact, Q: Implementation speed (Quick), R: Resilience in operation in UA context and C: Cost of generating the electricity (also referred to Levelized cost of electricity).

The four principal criteria are shown in Table 2. The criteria are W: **W**inter Impact, Q: **Q**uick implementation speed, R: **R**esilience in operation in UA context and C: **C**ost of generating the electricity (referred to as Levelized cost of electricity (LCoE)).

Each of the 14 parameters contribute to one of the four principal criteria. To give a comprehensive overview, this is shown both in Table 1 and in Table 2.

It can be seen in Table 2 in the column “parameter” that some of the criteria winter impact (W) and LCOE(C) consist of only one parameter while the criteria implementation speed(Q) and resilience(R) are evaluated based on 6 and 5 parameters.

Furthermore, some parameters can be given an absolute value (e.g., LCOE in Euro/kWh) which all in all makes it relatively easy to evaluate winter impact (W) and LCOE(C). For other criteria on the contrary, not all the parameters are assessed as absolute values.





























Icon	Indicator	Parameter	Bad	Medium	Good
	Capacity in wintertime	P1	 Low production in wintertime	  Medium production in wintertime	   High production in wintertime
	Implementation speed	P5, P6, P7, P8, P9, P11	 Long time frame	  Medium time frame	   Short time frame
	Resilience	P4, P10, P12, P13, P14	 Low resilience	  Medium resilience	   High resilience
	Levelized cost of electricity	P2,(P3)	 High costs	  Medium costs	   Low costs

Table 2: Overview of which parameters contribute to which criteria and visualizing of the ratings, the more icons the better rating.

Implementation speed(Q) is based on the estimated time consumption for more different phases in the project development, represented by different parameters. Some of the parameters are measured in weeks and can thereby be summarized, this is the case for P5-“Regulation requirement in the project development process”, P6-“Delivery time and availability of components and materials” and P8-“Technical installation time (after clearance)”, whereas P7-“Requirements for logistics and transportation infrastructure”, P9-“Requirements for skilled staff in construction

phase” and P11-“Requirements for electricity grid infrastructure” are based on qualitative assessments, where the technologies are ranked relative to each other. Furthermore, for the parameters measured in weeks it should be considered if some of the periods could overlap.

When evaluating for Resilience(R), there is no absolute values of same unit for all the five parameters that influence the criteria. Therefore, the five parameters are for each technology evaluated relatively to the performance of the other technologies. Hereafter the five parameters are

weighted. P4-“*Distributed generation*” and P13-“*Possibility for camouflage and sheltering*” are assessed to be most important. Therefore, P4 and P13 are each given the weight 30%. P10-“*Grid balancing capacity*” and P14-“*Risk associated with fuel supply*” are given 15% weight each, while P12-“*Requirements for skilled staff for operation and maintenance and for special spare parts*” are given 10% weight.

It should be noted that for the parameter P13 -“*Possibility for camouflage and sheltering*”.

The evaluation only clarifies how easy the technology is to camouflage or shelter, e.g., by covering it with a concrete lid or protecting it with an anti-drone net. Therefore, the assessment is based on the physical “configuration” of the technology. Thus, there is no evaluation of what types of attacks the different shelters can withstand.

A general score is calculated as the simple average of the four criteria is illustrated in Figure 1.

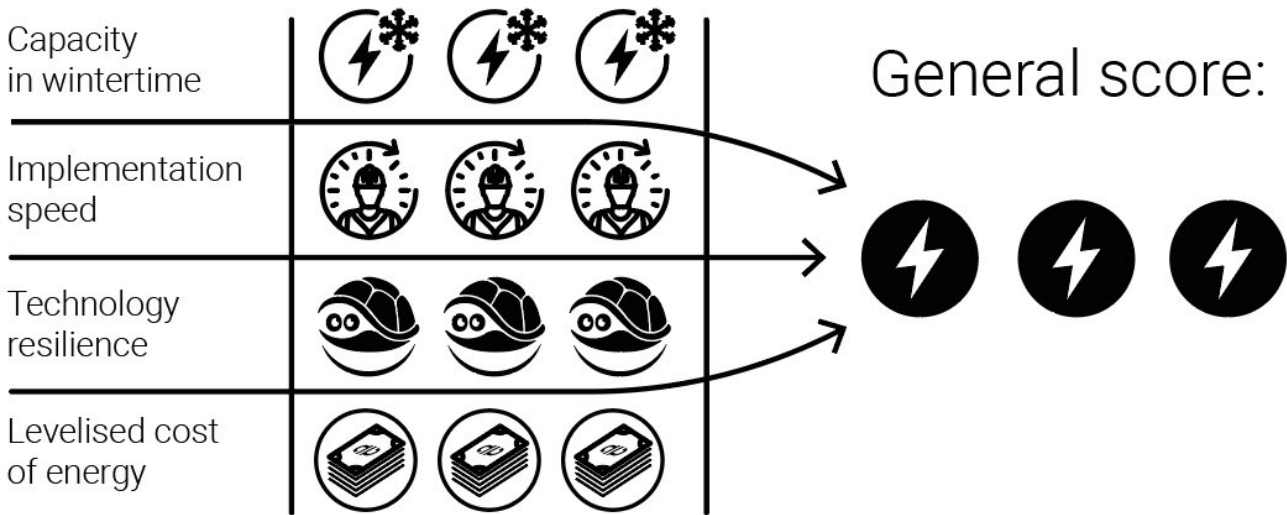

Figure 1: Example I. Visualization of criteria and general score - the more icons the better rating.

Technology frontpage

On each technology frontpage, the criteria evaluations are represented graphically with the following icons shown in Table 2 and Figure 1.

LCOE calculations

The method is described in Appendix B: LCOE calculations.

The Overall Findings of the Evaluations: Technology summaries

Figure 2 presents an overview of the evaluation of the highest rated technology within each of the categories. The more icons the better rating



Figure 2: Technology Summaries, of best technologies in each category (Gas engines, rooftop PVs household, commercial and industrial, Onshore wind turbines, farms >20MW, Coal power plants retrofitting, Batteries Li-ion community scale, biomass CHP medium wood pellets, Hydro RoR micro.

In Table 3, a comprehensive evaluation of the sub-technology level is presented, focusing on the four principal criteria. Gas engines and turbines fueled by natural gas outperform the others, securing the highest overall score. The small size wood pellet CHP also performs well, though slightly less so.

Gas turbines, gas engines and other thermal plants possess the greatest potential for supplying energy during winter time, contrary to for example solar PV which is limited during the winter season.

Gas engines, rooftop PV, household wind turbines and batteries could be implemented within half a year, while gas turbines, large PV, used onshore wind turbines, small size biomass CHPs and retrofitted coal are deemed realistic for implementation by 2024-25 due to short approval processes and shorter construction timelines. In contrast, other technologies face longer timelines exceeding 1.5 years due to complex approval procedures and extended delivery or installation/construction times. This applies, for example, to onshore wind, medium size biomass CHP fueled by straw/husk and wood chips, small size hydro power plants (RoR) and biogas engine solely supplied by a greenfield project biogas plant.

Reducing the implementation timeline for large wind turbine projects is feasible by relaxing environmental impact assessment requirements. Under ideal conditions, including the use of used wind turbines, projects could potentially be established within 1.5 to 2 years, emphasizing the importance of regulatory flexibility for sustainable energy solutions.

Gas turbines and particular small scale gas engines also demonstrate a high level of resilience since they can be sheltered and protected more effectively due to their smaller size and flexibility in location. The same is true for batteries. Resilience has also been deemed high for small and medium scale PV and household wind turbines due to their size, it is assumed that they are not seen as an important target.

When considering the cost effectiveness (LCoE) of the technologies over short time and only for the winter production gas technologies, onshore wind, coal retrofitting, all medium size biomass CHP and small hydro RoR plants turn out to be the most cost efficient.

When calculating the LCOE over the full lifetime of the technology, including the total electricity production, the most cost-effective solutions are large-scale wind farms, hydro power plants, and PV. These technologies are renewable and have no fuel cost and low maintenance and operating costs. This contributes to a low LCOE over their total operational lifetime.

Additionally, for most of the technologies transformers connection of the plant to the grid, is a critical component. Therefore, the delivery time for transformers is a critical parameter for most technologies. Stakeholders have mentioned that the delivery time for transformers are currently between 40 weeks and two years but that there are ways to acquire transformers faster. Therefore, a delivery time of two years for transformers is a risk but 2 years have not been assumed in the evaluations.

The tables below give an overview of the criteria evaluation for all technologies.

Criteria evaluation	1.a. Gas turb. simple cycle, NG	1.b. Gas engines, NG	1.c. Gas engines, biogas	2.a. PV residential rooftop	2.b.5.b PV comm. & industrial - with battery	2.b. PV comm. & industrial	2.c. PV utility scale, ground mounted	2.d. PV Utility scale, floating
Winter impact	WWW	WWW	WWW	W	W	W	W	W
Implementing speed	QQ	QQ	Q	QQQ	QQQ	QQQ	QQ	QQ
Resilience	RR	RRR	RR	RRR	RRR	RRR	RR	RR
Cost (LCOE, wintertime 2 years lifetime)	CCC	CCC	CCC	C	C	C	C	C
General score (1-3)	2,5	2,8	2,3	2,0	2,0	2,0	1,5	1,5

Criteria evaluation	3.a. Wind onshore turbines, farms (>20MW)	3.b. Used wind onshore turbines, farms (>20MW)	3.c. Wind onshore cluster (4,2-20MW)	3.d. Wind household turbines (<100kW)	4. Coal retrofitting	5.a. Bat, Li-Ion Utility scale	5.b. Bat, Li-Ion community scale
Winter impact	WW	WW	WW	WW	WWW	WW	WW
Implementing speed	Q	Q	Q	QQQ	QQ	QQ	QQ
Resilience	RR	RR	RR	RRR	R	RR	RR
Cost (LCOE, wintertime 2 years lifetime)	CCC	CCC	CCC	C	CCC	C	CC
General score (1-3)	2,0	2,0	2,0	2,3	2,3	1,8	2,0

Criteria evaluation	7.a. Wood pellets, CHP medium	7.b. Wood pellets, CHP Small	7c. Wood Chips, CHP Medium	7d. Wood Chips, CHP Small	7e. Straw, CHP Medium	7f. Straw, CHP Small	8.a. Hydro, RoR, small	8.b. Hydro, RoR, micro	8.c. Retrf Hydro power, dams incl PHS
Winter impact	WWW	WWW	WWW	WWW	WWW	WWW	WW	WW	WWW
Implementing speed	Q	QQ	Q	Q	Q	Q	QQ	QQ	Q
Resilience	RR	RR	RR	RR	RR	RR	RR	RRR	RR
Cost (LCOE, wintertime 2 years lifetime)	CCC	CCC	CCC	C	CCC	C	CCC	CCC	CCC
General score (1-3)	2,3	2,5	2,3	1,8	2,3	1,8	2,3	2,5	2,3

Table 3 Criteria evaluation matrix on sub-technology level, for the implementation speed green indicate that the technology could be in operation within less than 0,5 year, yellow indicate: could be in operation within 1-1,5 year and red that it would take more than 2 years to bring it in operation.

Details for the four principal criteria

Winter impact (production at wintertime) (W)

Thermal power plants, which include gas, coal, and biomass-based systems, achieve the highest performance scores. The primary reason for this is their dispatchability—the ability to adjust power output as demand or availability of energy supply changes. Unlike renewable sources, these plants can increase or decrease production based on demand, making them highly reliable during the winter months when energy demand often spikes.

The efficiency of wind and hydroelectric power systems can be influenced by seasonal weather patterns but in general both technologies demonstrate a fairly high availability during the winter season leading to a medium score.

Battery storage systems also receive a medium score, but for different reasons. The performance of these systems largely depends on the grid system they are integrated with, specifically whether there is sufficient capacity for them to charge during off-peak hours. If grid capacity is insufficient, batteries may not be able to store enough energy for use during peak demand periods, reducing their effectiveness.

Lastly, solar photovoltaic (PV) systems tend to perform the worst during the winter months. Shorter daylight hours and the lower position of the sun in the sky reduce the amount of sunlight that solar panels can convert into electricity. Additionally, snow and ice can cover panels, further decreasing their output. As a result, solar PV systems are often less reliable during the winter, leading to their lower performance score.

Implementation speed (Q)

When it comes to the speed of implementation, gas technologies, photovoltaic (PV) systems, household wind turbines, and battery storage

systems achieve the highest ratings. These technologies can be deployed relatively quickly due to their matured technology, streamlined approval processes, and the availability of off-the-shelf solutions.

Onshore wind farms, various biomass combined heat and power (CHP) technologies, coal retrofitting projects, and micro run-of-river hydro systems receive a medium rating. The implementation of these technologies involves more complex procedures, including regulatory compliance, planning, and construction, which can extend the deployment timeline.

The small run-of-river hydro systems and onshore wind turbines receive the lowest rating in terms of implementation speed. These projects often involve significant regulatory hurdles and lengthy planning processes, which can delay their implementation. Gas engines solely fueled supplied by a greenfield project biogas plant is also lowest rating in terms of implementation speed due to a significant regulatory and planning process and a complicated installation process for the biogas plant.

As illustrated in Figure 3, the time required for regulatory compliance, environmental survey and planning is particularly significant for onshore wind and small run-of-river hydro projects. These stages can considerably extend the overall implementation timeline for these technologies.

In general, small-scale technologies, such as rooftop PV systems and household wind turbines, can be deployed most rapidly. Their small size simplifies the approval and installation procedures, and these technologies are often available off-the-shelf. This contrasts with larger, megawatt-scale technologies, which are typically custom-built for specific projects, extending the time from order to operation.

The application of reused technologies could expedite the implementation process. For instance, in the case of wind turbines and gas

engines, reusing components or entire systems from decommissioned or upgraded projects can reduce both the time and cost associated with the deployment of these systems. Furthermore, the implementation timeline for wind turbine projects could be significantly

shortened if the requirements for environmental impact assessments were relaxed. These assessments, while crucial for ensuring the sustainability and environmental compatibility of these projects, are highly time-consuming.

Implementing speed (Q) assesment

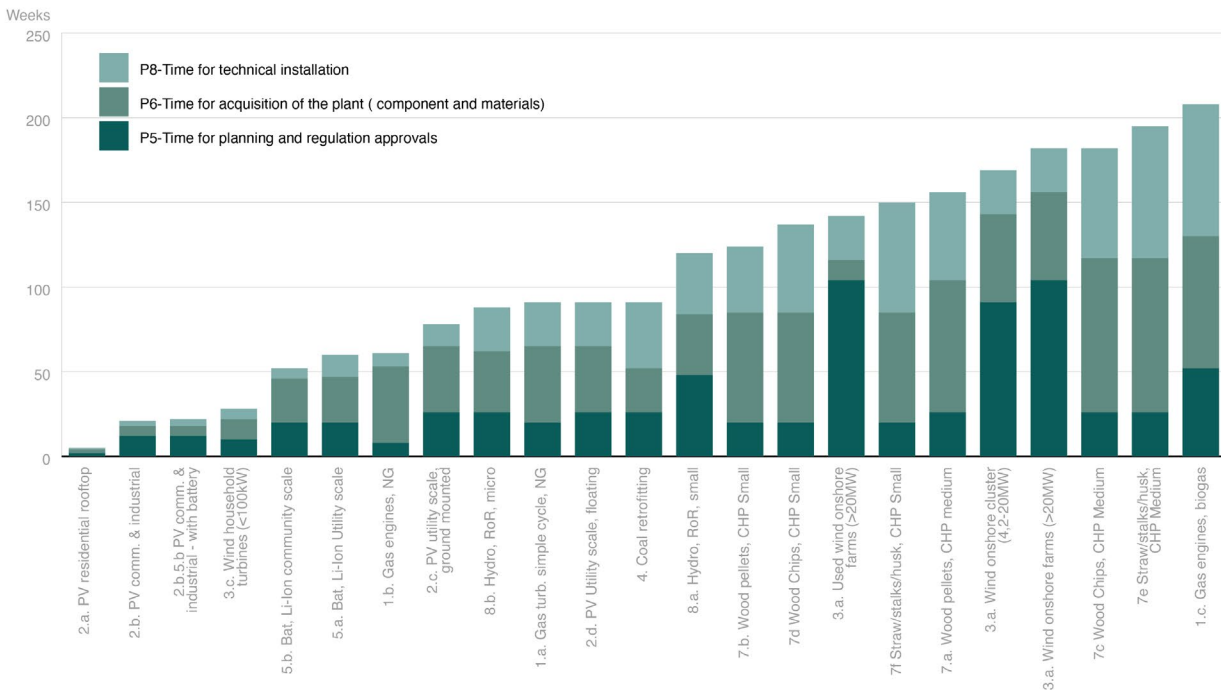

Figure 3: Assessment of the Implementing speed measured in weeks.

Resilience (R)

The resilience of energy technology is largely determined by its scale and distribution. Distributed technologies tend to be more resilient due to their ability to withstand and recover from disruptions. An overview of the resilience of the sub-technologies is shown in Figure 4.

Coal power plants have been given the lowest score in terms of resilience. The primary reason for

this is their centralized nature. These large-scale plants are not distributed across multiple locations, making them more vulnerable to disruptions. A single well-placed attack could potentially take out the entire plant, significantly impacting power supply.

On the other end of the spectrum, small gas technologies and battery storage systems receive the highest rating. These systems can be sheltered and protected more effectively due to their smaller size and flexibility in location. Their distributed nature also contributes to their resilience, as damage to one part of the system does not necessarily impact the entire network.

Small-scale technologies, such as rooftop solar panels and household wind turbines, also receive high scores. While these systems could potentially be damaged by enemy artillery, drones, or missiles, they are not typically considered high-value targets due to their small size and distributed nature.

Large-scale wind and solar farms also receive high scores since due to their dispersed layout it would require multiple attacks to take them out entirely. Moreover, the transformer stations connecting these farms to the high voltage power grid could be camouflaged or protected, for example, by a concrete ceiling.

Resilience (R) assesment

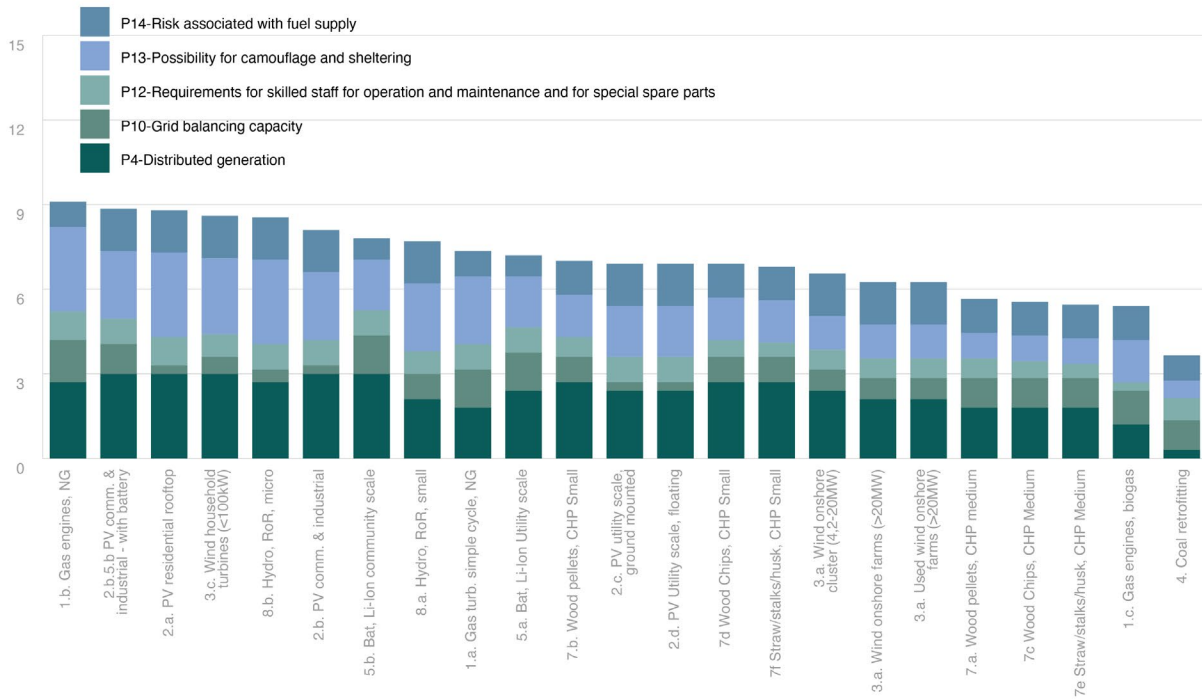

Figure 4: Overview of resilience assessment all sub-technologies, the parameters are weighted. The most resilient technology has the highest score and is to the most left, while the worst performing technology is the one with the lowest and placed to the most right.

LCOE (C)

The Levelized Cost of Electricity (LCOE) is a crucial metric in assessing the economic viability of different electricity generation technologies. It represents the per-megawatt-hour cost

(in real Euro) of building and operating a generating plant over an assumed financial life and duty cycle.

In this criteria analysis, the LCOE is evaluated over two winter seasons as well as over the full lifetime of the technologies, the results are shown in Figure 5. Cost of CO2 for Fossil fuel and biomass are not included in the short term LCOE.

In the short term, specifically over two winter seasons, gas turbines and gas engines demonstrate the lowest LCOE. This is primarily due to

their high production capability during the colder months and their relatively low initial investment costs. Following gas technologies, other large-scale thermal generation technologies and wind power also exhibit competitive short-term LCOEs.

On the other hand, all solar power technologies exhibit high short-term LCOEs. This is due to their limited power generation capacity during the winter months, coupled with their high initial investment costs.

LCOE - 2 years during winter

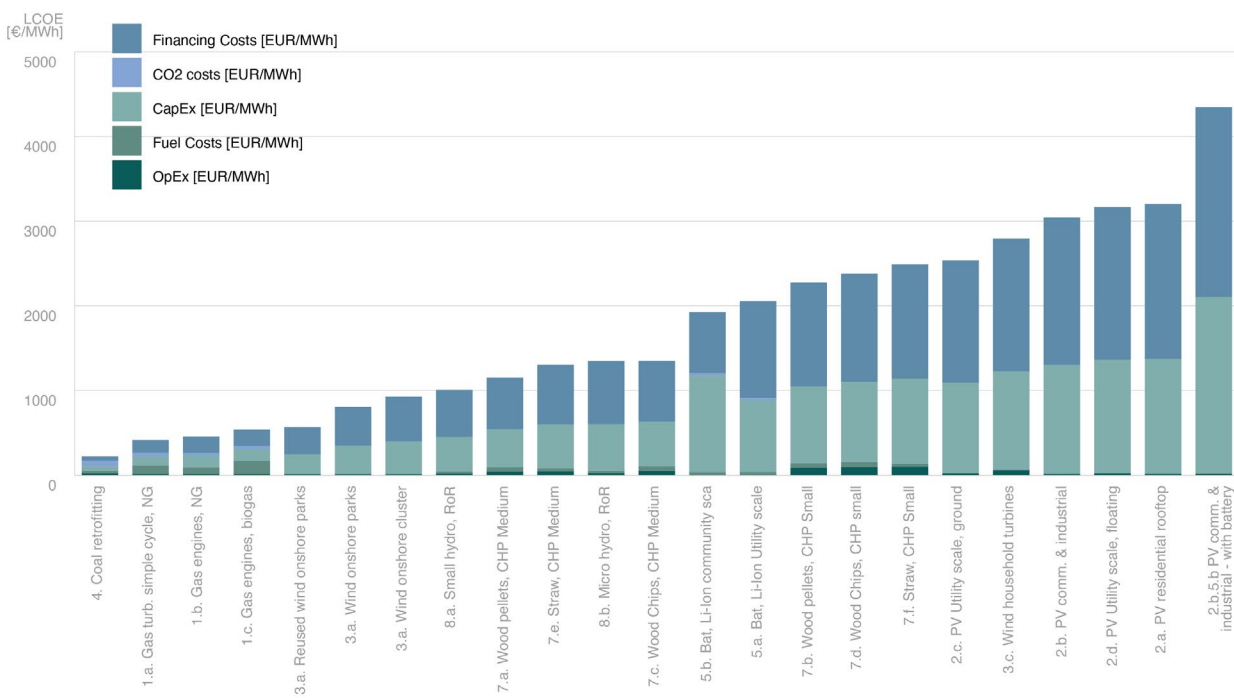

Figure 5: LCOE for wintertime production over 2 years

When considering the LCOE over the full lifetime of the technologies¹, shown in Figure 6, the picture changes. Large-scale wind and solar power, along with hydroelectric power, emerge as the most cost-effective solutions. These technologies, while requiring significant initial investment, offer substantial returns over their operational lifetime due to their renewable nature and low operating costs.

competitive lifetime LCOEs. Despite the environmental concerns associated with coal power, its substantial power output results in lower costs over the long term.

Following these, coal power plants and commercial scale rooftop PV systems also demonstrate

The remaining thermal power plants, along with batteries and household wind turbines, exhibit relatively high LCOEs. These technologies face challenges such as high fuel costs (for thermal plants) and high investment costs relative to their output (for batteries and household wind turbines), resulting in higher costs over the long term.

¹ Including financial cost(WACC) for all technologies and cost of CO2 for fossil fuel.

LCOE Calculation - Full lifetime - Transposed

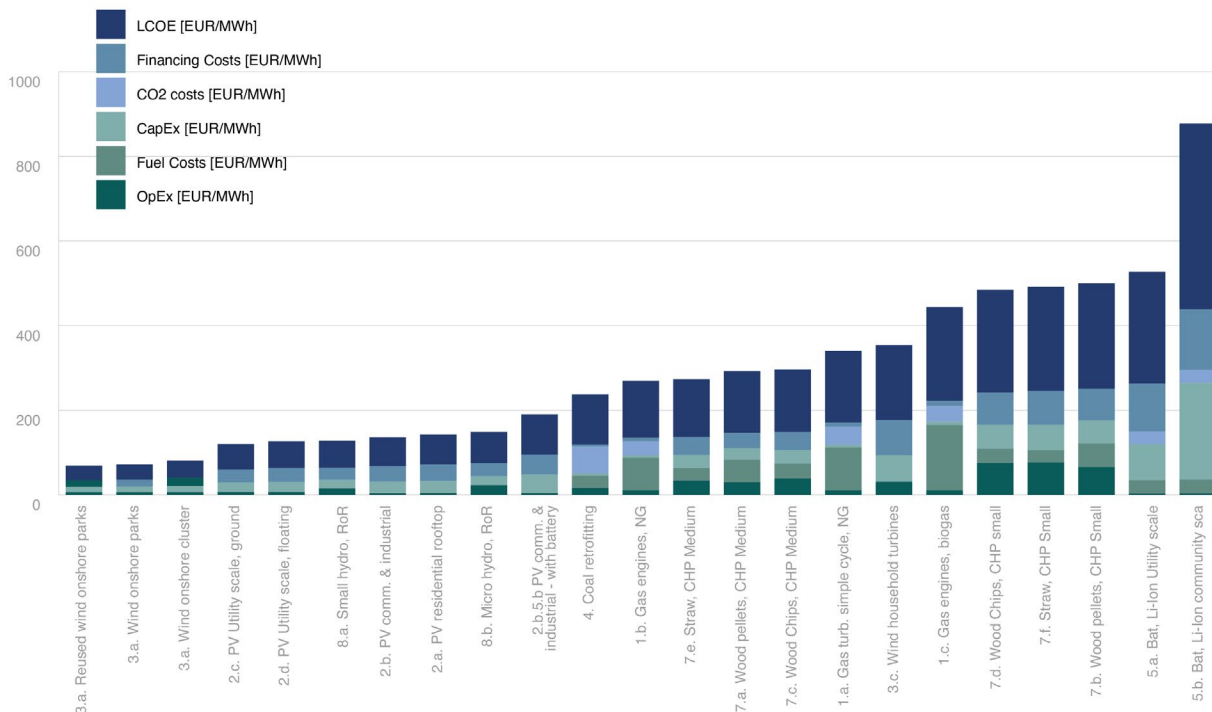

Figure 6: LCOE total production over the lifetime

Parameter evaluation overview

In Table 4 an overview of the rating of all parameters for all sub-technologies are shown.

Parameters	1.a. Gas turb. simple cycle, NG	1.b. Gas engines, NG	1.c. Gas engines, biogas	2.a. PV residential rooftop	2.b.5.b PV comm. & industrial - with battery	2.b. PV comm. & industrial	2.c. PV utility scale, ground mounted	2.d. PV Utility scale, floating
P1-Electricity production at wintertime	>75%	>75%	>75%	<30%	<30%	<30%	<30%	<30%
P2-Levelized Cost of Electricity (LCOE) short lifetime, winter production [€/MWh]	372	423	500	3204	4347	3043	2539	3169
P3-Levelized Cost of Electricity (LCOE) over lifetime [€/MWh]	170	135	222	71	95	68	60	63
P4-Distributed generation	5-40 MW	1-10 MW	1-10 MW	0,006 MW	0,1 MW	0,1 MW	15 MW	10 MW
P5-Regulation requirement in the project development process	In between	Quick and easy	Lengthy	Quick and easy	Quick and easy	Quick and easy	In between	In between

Parameters	1.a. Gas turb. simple cycle, NG	1.b. Gas engines, NG	1.c. Gas engines, biogas	2.a. PV residential rooftop	2.b.5.b PV comm. & industrial - with battery	2.b. PV comm. & industrial	2.c. PV utility scale, ground mounted	2.d. PV Utility scale, floating
P6-Delivery time and availability of components and materials	In between	In between	Lengthy and complicated	Quick and easy	Quick and easy	Quick and easy	In between	In between
P7-Requirements for logistics and transportation infrastructure	Low	Low	Low	Low	Low	Low	Medium	Medium
P8-Technical installation time (after clearance)	Medium-term	Quick and easy	Lengthy and complicated	Quick and easy	Quick and easy	Quick and easy	Quick and easy	Medium-term
P9-Requirements for skilled staff in construction phase	Low	Low	Medium	Low	Low	Low	Low	Low
P10-Grid balancing capacity	High	High	High	Low	Medium	Low	Low	Low
P11-Requirements for electricity grid infrastructure	Easy	Easy	Moderate	Easy	Easy	Easy	Challenging	Challenging
P12-Requirements for skilled staff for operation and maintenance and for special spare parts	Low	Low	High	Low	Low	Low	Low	Low
P13-Possibility for camouflage and sheltering	High potential	High potential	Medium potential	High potential	High potential	High potential	Medium potential	Medium potential
P14-Risk associated with fuel supply	Medium risk	Medium risk	Low risk	Low risk	Low risk	Low risk	Low risk	Low risk

Parameters	3.a. Wind onshore farms (>20MW)	3.b. Used wind onshore farms (>20MW)	3.c. Wind onshore cluster (4,2-20MW)	3.d. Wind household turbines (<100kW)	4. Coal retrofitting	5.a. Bat, Li-Ion Utility scale	5.b. Bat, Li-Ion community scale
P1-Electricity production at winter-time	50%	50%	50%	50%	>75%	50%	50%
P2-Levelized Cost of Electricity (LCOE) short lifetime, winter production [€/MWh]	808	568	927	2795	160	2025	1899
P3-Levelized Cost of Electricity (LCOE) over lifetime [€/MWh]	36	35	40	177	119	264	439
P4-Distributed generation	>20 MW	>20 MW	4,2-20 MW	0,1 MW	500 MW	5-150 MW	40-200 kW
P5-Regulation requirement in the project development process	Lengthy	Lengthy	Lengthy	Quick and easy	In between	In between	In between

Parameters	3.a. Wind onshore farms (>20MW)	3.b. Used wind onshore farms (>20MW)	3.c. Wind onshore cluster (4,2-20MW)	3.d. Wind household turbines (<100kW)	4. Coal retrofitting	5.a. Bat, Li-Ion Utility scale	5.b. Bat, Li-Ion community scale
P6-Delivery time and availability of components and materials	In between	Quick and easy	In between	Quick and easy	In between	In between	In between
P7-Requirements for logistics and transportation infrastructure	High	High	High	Low	Medium	Low	Low
P8-Technical installation time (after clearance)	Medium-term	Medium-term	Medium-term	Quick and easy	Medium-term	Quick and easy	Quick and easy
P9-Requirements for skilled staff in construction phase	Medium	Medium	Medium	Medium	Medium	Low	Low
P10-Grid balancing capacity	Medium	Medium	Medium	Medium	Medium	High	High
P11-Requirements for electricity grid infrastructure	Moderate	Moderate	Moderate	Easy	Moderate	Easy	Easy
P12-Requirements for skilled staff for operation and maintenance and for special spare parts	Medium	Medium	Medium	Low	Low	Low	Low
P13-Possibility for camouflage and sheltering	Medium potential	Medium potential	Medium potential	High potential	Low potential	Medium potential	Medium potential
P14-Risk associated with fuel supply	Low risk	Low risk	Low risk	Low risk	Medium risk	Medium risk	Medium risk

Parameters	7.a. Wood pellets, CHP medium	7.b. Wood pellets, CHP Small	7c Wood Chips, CHP Medium	7d Wood Chips, CHP Small	7e Straw, CHP Medium	7f Straw, CHP Small
P1-Electricity production at wintertime	>75%	>75%	>75%	>75%	>75%	>75%
P2-Levelized Cost of Electricity (LCOE) short lifetime, winter production [€/MWh]	1153	2277	1351	2380	1306	2491
P3-Levelized Cost of Electricity (LCOE) over lifetime [€/MWh]	146	250	148	242	137	246
P4-Distributed generation	20-35 MW	3-3,15 MW	20-35 MW	2,85-3 MW	24-26 MW	2,95-3,10 MW
P5-Regulation requirement in the project development process	In between	In between	In between	In between	In between	In between
P6-Delivery time and availability of components and materials	Lengthy and complicated	Lengthy and complicated	Lengthy and complicated	Lengthy and complicated	Lengthy and complicated	Lengthy and complicated
P7-Requirements for logistics and transportation infrastructure	Medium	Medium	Medium	Medium	Medium	Medium
P8-Technical installation time (after clearance)	Lengthy and complicated	Medium-term	Lengthy and complicated	Lengthy and complicated	Lengthy and complicated	Lengthy and complicated

Parameters	7.a. Wood pellets, CHP medium	7.b. Wood pellets, CHP Small	7c Wood Chips, CHP Medium	7d Wood Chips, CHP Small	7e Straw, CHP Medium	7f Straw, CHP Small
P9-Requirements for skilled staff in construction phase	Medium	Medium	Medium	Medium	Medium	Medium
P10-Grid balancing capacity	Medium	Medium	Medium	Medium	Medium	Medium
P11-Requirements for electricity grid infrastructure	Moderate	Easy	Moderate	Easy	Moderate	Easy
P12-Requirements for skilled staff for operation and maintenance and for special spare parts	Medium	Medium	Medium	Medium	Medium	Medium
P13-Possibility for camouflage and sheltering	Low potential	Medium potential	Low potential	Medium potential	Low potential	Medium potential
P14-Risk associated with fuel supply	Low risk	Low risk	Low risk	Low risk	Low risk	Low risk

Parameters	8.a. Hydro, RoR, small	8.b. Hydro, RoR, micro	8.c Retrf Hydro power, dams incl PHS
P1-Electricity production at wintertime	50%	50%	>75%
P2-Levelized Cost of Electricity (LCOE) short lifetime, winter production [€/MWh]	1008	1350	n.a.
P3-Levelized Cost of Electricity (LCOE) over lifetime [€/MWh]	64	74	n.a.
P4-Distributed generation	10-100 MW	0-10 MW	100 MW
P5-Regulation requirement in the project development process	Lengthy	In between	Lengthy
P6-Delivery time and availability of components and materials	In between	In between	In between
P7-Requirements for logistics and transportation infrastructure	Medium	Low	Medium
P8-Technical installation time (after clearance)	Medium-term	Medium-term	Medium-term
P9-Requirements for skilled staff in construction phase	Medium	Medium	Medium
P10-Grid balancing capacity	Medium	Low	Low
P11-Requirements for electricity grid infrastructure	Moderate	Moderate	Easy
P12-Requirements for skilled staff for operation and maintenance and for special spare parts	Low	Low	Low
P13-Possibility for camouflage and sheltering	High potential	High potential	Medium potential
P14-Risk associated with fuel supply	Low risk	Low risk	Low risk

Table 4: Parameter evaluation matrix

Cross cutting issues as issues related to the grid as operational challenges in the UA grid system and challenges related to integration of renewable energy technologies, financial issues and issues related to transformers are outlined in appendix C.

EVALUATION OF CHOSEN TECHNOLOGIES

In this section, technologies are evaluated regarding criteria and parameters.



Gas Power Plants

Capacity
in wintertime



Implementation
speed



Technology
resilience



Levelized cost
of electricity



General Score:



GAS POWER PLANTS

The rating on the frontpage shows the score for the technology achieving the highest general score among the sub technologies evaluated in the chapter. The more icons the better

performance². For gas technologies it is the gas engines fueled by natural that achieve the best score. The scores for all sub-technologies are shown in Table 5.

Criteria evaluation	1.a. Gas turb. simple cycle, NG	1.b. Gas engines, NG	1.c. Gas engines, biogas
Capacity in wintertime	WWW	WWW	WWW
Implementation speed	QQ	QQ	Q
Technology resilience	RR	RRR	RR
Levelized cost of electricity	CCC	CCC	CCC
General score (1-3)	2.5	2.8	2.3

Table 5: Gas power plants - Overall criteria evaluation matrix

This chapter covers three types of gas power plants:

- Gas turbines, simple cycle, fueled by natural gas
- Gas engine, fueled by natural gas
- Gas engine, fueled by biogas (not upgraded), solely supplied by a greenfield project biogas plant.

Both gas turbines and gas engines can be manufactured across a broad spectrum of

sizes, spanning from a few kilowatts to multiple megawatts. Specifically for this project, the focus is on an open cycle gas turbine with a capacity ranging from 5 to 40 MW, and a gas engine with a capacity ranging from 1 to 10 MW. The selection of these technologies is primarily intended to underscore distinctions in gas power plants of varying sizes, rather than emphasizing the choice between turbine and engine technologies.

² See detailed explanation in Table 2: Overview of which parameters contribute to which criteria and visualizing of the ratings, the more icons the better rating.

Gas turbines, simple cycle

Brief technology description

The main components of a simple-cycle (or open cycle) gas turbine power unit are a gas turbine, a gear (when needed), compressor, combustion chamber, and a generator; see Figure 7.

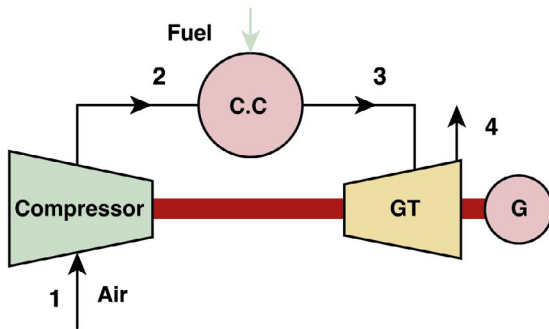

Figure 7: Process diagram of a SCGT[1]

Gas turbines can be equipped with compressor intercoolers where the compressed air is cooled to reduce the power needed for compression. The use of integrated recuperators (preheating of the combustion air) to increase efficiency can also be made by using air/air heat exchangers – at the expense of an increased exhaust pressure loss. Gas turbine plants can have direct steam injection in the burner to increase power output through expansion in the turbine section (Cheng Cycle). Small (radial) gas turbines below 100 kW are now on the market, the so-called micro-turbines. These are often equipped with preheating of combustion air based on heat from gas turbine exhaust (integrated recuperator) to achieve reasonable electrical efficiency (25-30%).

Criteria evaluation	1.a. Gas turb. simple cycle, NG
Capacity in wintertime	WWW
Implementation speed	QQ
Technology resilience	RR
Levelized cost of electricity	CCC
General score (1-3)	2.5

Table 6: Gas turbines, simple cycle – criteria evaluation matrix

Winter impact (production at wintertime)

Gas turbines will be able to provide a significant contribution to the Ukrainian power system during wintertime. Gas power plants are dispatchable, and it is realistic for them to generate with a high capacity factor approaching, 90-100%, during the winter if deemed necessary.

Implementing speed

The implementation time is very dependent on size of the project and the choice of technology. Delivery time for the technology itself is deemed to be around 1 year but could potentially be lower if used equipment is applied, whereas the installation would typically take half a year for a project in the size of 10-40 MW. Including the time for planning and regulation approvals the total time for project delivery could be around 1.5 years.

Resilience

The resilience of gas turbines can be attributed to two key factors. Firstly, their modest capacity enables the dispersion of gas turbines over a wide geographic area. This dispersion minimizes vulnerability to potential air strikes from artillery, missiles, or drones. Secondly, the relatively small footprint of gas turbines allows for installation within bunkers, which can be effectively camouflaged to enhance their security. Potential disruptions to the gas supply, either in select regions of Ukraine or on a national level, caused to terrorist attacks, makes up a risk that cannot be neglected.

Generation costs (LCOE), short term and over the lifetime

Due to their low upfront costs³ and great potential for generation during winters, gas turbines demonstrate the lowest generation cost of all technologies over the course of two winters. On the other hand, the levelized cost over their entire lifetime is about two to three times higher than the costs of wind and solar power.

³ The investment cost is low compared to the other technologies included in this catalogue.

Data sheet
In Appendix F

Gas engine

The section covers

- Gas engine, fueled by natural gas.
- Gas engine, fueled by not upgraded biogas, solely supplied by a greenfield project biogas plant.

There is no difference in the gas engine technology, the efficiency is slightly lower when fuelled by not upgraded biogas. The biogas plant technology is described in the chapter Biogas.

Brief technology description

The evaluation includes a gas engine fueled by natural gas and by not upgraded biogas.

A gas engine for co-generation of heat and power drives an electricity generator for the power

production. Electrical efficiency up to 45- 48 % can be achieved. The engine cooling water (engine cooling, lube oil and turbocharger intercooling) and the hot exhaust gas can be used for heat generation, e.g., for district heating or low-pressure steam. Typical capacity of a gas engine ranges from 5 kW_e to 10 MW_e.

Two combustion concepts are available for spark ignition engines: lean-burn and stoichiometric combustion engines. Another ignition technology is used in dual-fuel engines. A dual-fuel engine (diesel-gas) with pilot oil injection is a gas engine that – instead of spark plugs – uses a small amount of light oil (1% – 6%) to ignite the air-gas mix by compression (as in a diesel engine). Dual fuel engines can often operate on diesel oil alone as well as on gas with pilot oil for ignition. Figure 8 shows a gas engine cogeneration unit with heat recovery boilers and an absorption steam driven heat pump to obtain a high heat production and highest possible overall efficiency.

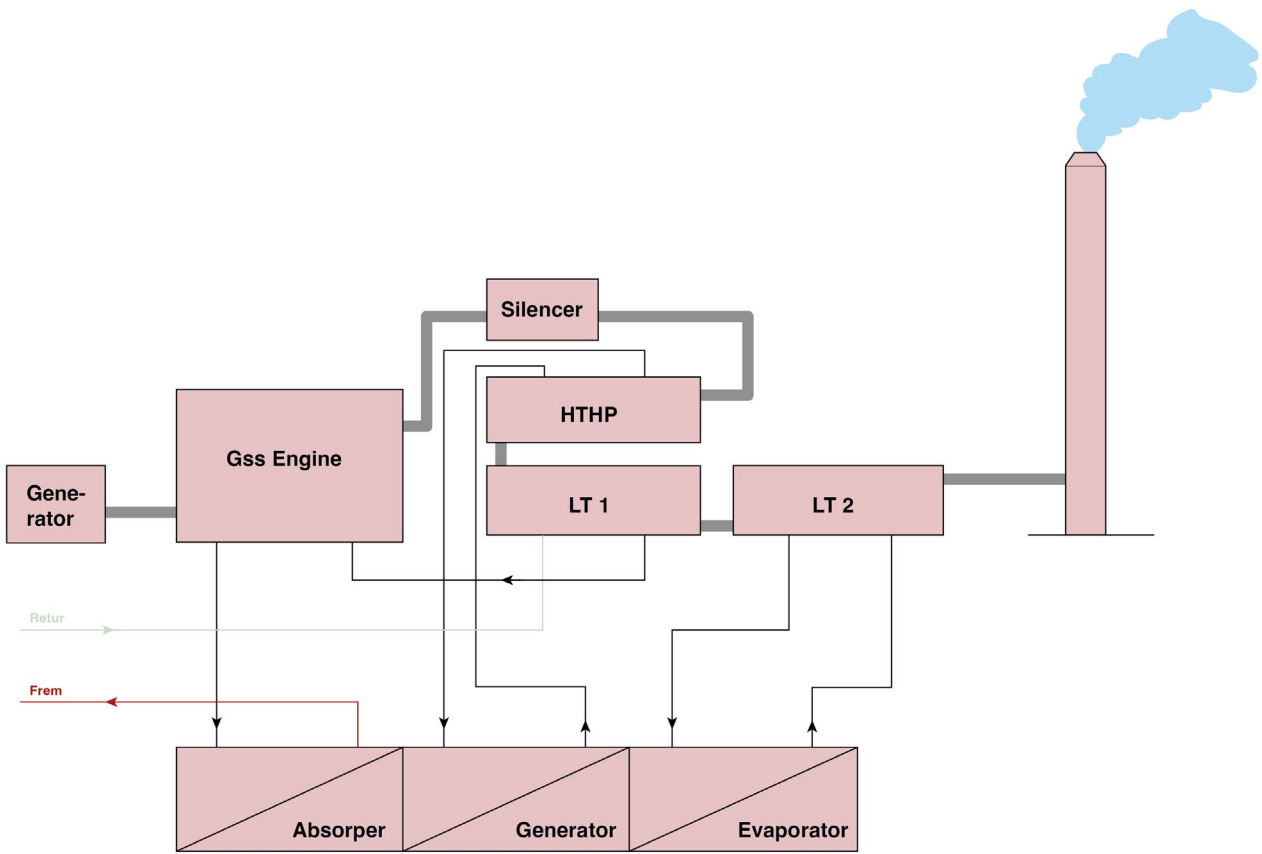

Figure 8: Gas engine cogeneration unit

Criteria evaluation

The evaluation is conducted for gas engine fueled by natural gas and by biogas. For the biogas version it is assumed that a new biogas plant shall be installed, and that the engine is fueled directly and solely from the biogas plant. However, the cost of the biogas plant is not included in the LCoE calculations, but in all the other parameter assessments.

Criteria evaluation	1.b. Gas engines, NG	1.c. Gas engines, biogas
Capacity in wintertime	WWW	WWW
Implementation speed	QQ	Q
Technology resilience	RRR	RR
Levelized cost of electricity	CCC	CCC
General score (1-3)	2.8	2.3

Table 7: Gas engines – criteria evaluation matrix

Winter impact (production at wintertime)

Gas engines can significantly contribute to the Ukrainian power system in winter. Gas engines are dispatchable and can realistically operate at a high-capacity factor, approaching 90-100%, if needed.

Implementing speed

The implementation timeline hinges significantly on the project’s size. Technology delivery is estimated at around 1 year, potentially shorter with the use of pre-owned equipment. Installation durations vary, taking few weeks for a smaller 1 MW project and up to half a year for a larger 10 MW project requiring customized installation. Accounting for planning and regulatory approvals, the overall project delivery time could be streamlined to less than 1 year.

Resilience

The resilience of gas engines is linked to two factors. Firstly, their moderate capacity facilitates the dispersion of gas engines across a broad geographic area, reducing vulnerability to potential air strikes from artillery, missiles, or drones.

Secondly, the very compact footprint of gas engines allows for bunker installation, enhancing security through effective camouflage. The risk of potential disruptions to the gas supply, whether in specific regions of Ukraine or nationally due to terrorist attacks, is a significant concern that cannot be overlooked.

Generation costs (LCOE), short term and over the lifetime

Because of their low initial investment and considerable winter generation potential, gas engines exhibit the lowest generation cost among all technologies over two winters. However, the levelized cost over their entire lifespan is approximately two to three times higher than that of utility scale wind and solar power.

Gas power parameter evaluation

This section covers both gas turbines and gas engines since their characteristics, challenges and opportunities are largely the same. Engines using biogas as fuel are also discussed.

Parameters	1.a. Gas turb. simple cycle, NG	1.b. Gas engines, NG	1.c. Gas engines, biogas
P1-Electricity production at wintertime	>75%	>75%	>75%
P2-Levelized Cost of Electricity (LCOE) short lifetime, winter production [€/MWh]	372	423	500
P3-Levelized Cost of Electricity (LCOE) over lifetime [€/MWh]	170	135	222
P4-Distributed generation	5-40 MW	1-10 MW	1-10 MW
P5-Regulation requirement in the project development process	In between	Quick and easy	Lengthy
P6-Delivery time and availability of components and materials	In between	In between	Lengthy and complicated
P7-Requirements for logistics and transportation infrastructure	Low	Low	Low
P8-Technical installation time (after clearance)	Medium-term	Quick and easy	Lengthy and complicated
P9-Requirements for skilled staff in construction phase	Low	Low	Medium
P10-Grid balancing capacity	High	High	High
P11-Requirements for electricity grid infrastructure	Easy	Easy	Moderate
P12-Requirements for skilled staff for operation and maintenance and for special spare parts	Low	Low	High
P13-Possibility for camouflage and sheltering	High potential	High potential	Medium potential
P14-Risk associated with fuel supply	Medium risk	Medium risk	Low risk

Table 8: Gas Power – parameters evaluation matrix. The LCOE unit is [€/MWh].

P1: Electricity production at wintertime (W)

Gas turbines and gas engines, rely on gas as a fuel. If there is fuel available, they can operate at their full capacity any hour of the day, except for the planned and forced outages. Depending on the specific gas- turbine or engines, there are different requirements for when the plant should be maintained, meaning that there will be some weeks of the year where it is planned that the gas turbine or engine will be out of operation. Typically, the maintenance is planned to be done during the summer, when the need for the plant is lower. Forced outages can happen for multiple reasons, but typically occur due to some form of breakdown, which occurs during production. Therefore, it is estimated that the gas power plant can operate full load more 95% of the time during winter, which

correspond to 4150 FLH hours. 4150 FLH corresponds to a little more than the annual FLH of a onshore wind turbine, located in the Ukrainian region with the best wind profiles and above twice the annualized FLH of a PV plant located in the Ukrainian region with the best solar profile. In summary, gas turbines and engines may be considered a great power source during the wintertime.

P2/3 LCOE expected production

It is expected that the need for electricity delivered by gas engine or turbine is considerably lower during the summer. Because the power consumption is lower, partly due to that the heat demand is considerably lower. Thereby, a larger share of the electricity can be generated through technologies like photovoltaics, wind,

hydro and nuclear. Furthermore, gas engines and turbines also compete against other fuel-based power plants and combined heat and power plants.

Due to these reasons, all though the gas technologies could operate full capacity 8100 hours per year, it is assumed that a gas turbine and engine will operate, to what equates as, full capacity for 5.000 hours during a year, so-called Full Load Hours (FLH). caused by Russian terror, then the FLH can be expected to be higher.

The majority of the production is likely to happen during the winter period, therefore it is assumed that 75% of the FLH will occur during the wintertime, which means that gas engine and turbine, is assumed to operate 3.750 full load hours during the wintertime although 4150 was possible.

P2: Levelized Cost of Electricity (LCOE) short lifetime, winter production (C)

In the emergency scenario, where the technology is only utilized for two winter periods, the LCOE of the natural gas engine and turbine are the lowest of all technologies assessed. For a gas turbine with a simple cycle, the LCOE is expected to be 370 €/MWh, compared to about 420 €/MWh for the gas engine.

The natural gas engine and turbines stand out because the majority of their lifetime expenditure is caused by fuel consumption, whereas the investment cost is relatively low, and so is the cost for operation and maintenance. When only assessing the cost over a reduced operational period of two years, the amount of fuel consumed and thus the fuel costs are proportionately lower in comparison to the investment cost, regarding the LCOE.

Gas engines fueled by not upgraded biogas would have slightly higher investment cost than that of the natural gas engine, to make it possible to use biogas which also contains a large portion of CO₂ as a fuel, in an efficient way. Furthermore, fuel is a little more costly. This drives the LCOE of the biogas engine to be

significantly higher level than that of the natural gas engine.

P3: Levelized Cost of Electricity (LCOE) over lifetime (C)

For a gas turbine with a simple cycle, the LCOE over lifetime is expected to be approx. 170 €/MWh. For the gas engine the LCOE is expected to be about 135 €/MWh. This is two-three times higher than utility scale solar and wind power but less than the biomass technologies included and the small-scale wind and solar technologies. Fuel costs make up most costs and therefore obviously, the generation cost from gas technologies, are highly sensitive to the developments of the gas price. In the projected LCOE the long-term gas price is set to 35 €/MWh (HHV), assuming that LNG sets the price in the European market.

P4: Distributed generation (R)

Typical gas turbines have a generation capacity that ranges from 1-40 MW and the typical gas engines have a generation capacity of 1-10 MW. This means that both gas engines and turbines offer a scalable choice of decentralized energy production. As it might be more typical for a gas turbine to have a capacity above 5MW, the gas turbines can generally be considered to have a medium distributed generation capacity. As gas engines have a power generation capacity of 1-5MW, the gas engine can be easy to distribute. Given the current situation in Ukraine, there are several compelling reasons to favor distributed installations. These installations, located near demand centers, offer the advantage of reducing dependence on the transmission grid, thereby mitigating the risks associated with potential power production capacity loss. Moreover, local power generation at the end-user's site diminishes the necessity for extensive electricity transmission, consequently bolstering energy security.

Additionally, the dispersion of gas turbines and gas engines across a broad geographic area renders them less susceptible to potential air

strikes from artillery, missiles, or drones, further enhancing their resilience.

P5: Regulation requirement in the project development process (Q)

For the natural gas engine, turbine and the bio-gas engine, the regulation requirement in the project development process is considered to be quick and easy. This is due to the fact, that these three technologies come in modular builds, which are well known and are pre certified for operation. Furthermore, they do not require a lot of space, which makes the planning process easier as the building in which the technologies will be placed, has a smaller impact on the local environment. This means that the process carrying out an environmental impact assessment report is assumed to be relatively short.

Therefore, for the natural gas engine, turbine and the biogas engine, the time spent on planning and regulation approvals is estimated to be around 20 weeks.

P6: Delivery time / availability of components and materials (Q)

The delivery time for natural gas engines and turbines is expected to be approximately 1 year if they are ordered today. The reason why it takes so long for the delivery is the fact that the manufacturers do not build an inventory of natural gas engines and turbines, they build the units when they are ordered. This is typically due to different requirements from the end user, which means that even though the gas engines and turbines are built as a modular unit, there can be a varying degree of capacity size and the manufacturers do not want to build a large inventory of different units, as the investment cost is quite high and there is no guarantee that the units will be purchased.

This means that when a gas engine or turbine is ordered, the manufacturer starts to order the components, such as engine blocks, cylinder heads, pistons, crankshafts etc. Some

of these components the manufacturer might craft themselves. But the process of receiving all these components takes time, as there currently is a constriction on the raw materials and components, which means that there will be a wait time before the components and needed materials are received. This delays the beginning of the assembly process, on top of the assembly process also requiring some time. Furthermore, through the interviews, it became apparent that there are some constraints on the availability of transformers, which with some exceptions are needed to couple the gas engine and turbine to the grid. The transformers are expected to be deliverable within 1 year, which means that even if the gas engine or turbine is assembled ahead of time, they might not be able to be coupled to the grid because of a missing transformer. Through the interviews, some manufacturers of gas engines expressed that a 0,5-1MW gas engine, might be connectable to the grid, without any transformer.

Compared to some of the other technologies, 1 year is considered to be in between in regards of delivery time.

P7: Requirements for logistics and transportation infrastructure (Q)

This unit and the components needed for the construction typically requires transport by equipment of the size of a semitruck, which requires a road. This means that the gas engine and turbine, have a low requirement for logistics and transportation infrastructure, as roads and semitrucks are easily available.

P8: Technical installation time (min time after clearance) (Q)

Installation time is dependent on the project size. For larger gas turbines and gas engines (2-5 MW or above), after the gas engine and turbine has been delivered to the target location, it will take around 26 weeks to do all the technical installation, even though the turbine or engine comes as a module. This is due to the fact that the site needs to be prepared for

construction and there needs to be built roads to the plant, utilities connections and other necessary infrastructure. The foundation for the engines or turbines needs to be constructed, so do the associated structures. Then the engines or turbines can be installed together with the ancillary equipment. After this is done, the functionality, safety and production can be tested. All these processes are expected to take time, but can be lowered with some preparation, but even if this is done, it is expected to take 26 weeks in general as it cannot be expected that everything will operate smoothly. Contractors might be delayed or there might be some scheduling issues, which will cause some down time during the construction.

When compared to the other technologies, the installation time is expected to be in the medium range.

Smaller gas engines with a capacity up to about 1 MW (cascade systems with higher capacity are also possible) may be supplied in a container system allowing for a rapid installation within a few weeks.

P9: Requirements for skilled staff in construction phase (Q)

During the construction phase, general laborers, heavy equipment operators, concrete workers, welders, plumbers, electricians, HVAC technicians and safety specialist workers are required. These laborer types are easy to acquire for the construction phase, as they are readily available in Ukraine or can be sent from other countries, depending on company policies. If companies cannot send their employees to Ukraine to perform the construction due to security concerns, some companies can and will educate general laborers from Ukraine. During the interviews, it was established that the education for assembling a small gas engine or turbine plant, might take some month, which could take place during the assembly of the ordered gas engines or turbines, which is why the requirement for skilled staff is low during construction phase.

P10: Grid balancing capacity (R)

If there is natural gas or biogas available, the natural gas engine, -turbine and biogas engine, can produce electricity at any hour of the day and the startup is very quick. Therefore, the grid balancing capacity is considered to be high for all these technologies.

P11: Requirements for electricity grid infrastructure (Q)

Depending on the generation capacity of the gas engines or turbines, there will be different requirements for the electricity grid, when coupling the gas engines and turbines to the power grid. As gas turbines can have a generation capacity above 10MW, the requirements for connecting the gas turbines to the grid are higher than that of a gas engine. Which is why the requirement for the coupling of the gas turbine to the grid, is considered to be moderate, as they can be connected to almost any grid, as long as the gas turbines are coupled via a transformer. As previously mentioned, the gas engines might not require a transformer if the generation capacity is below 1MW and the gas engines can be connected to the grid almost anywhere, which is why the connection of a gas engine to the electricity grid is expected to be easy.

P12: Requirements for skilled staff for operation and maintenance and for special spare parts (R)

To keep a gas engine or turbine plant in operation, operations-, maintenance-, instrumentation-, electrical- and mechanical technicians are required. Depending on the plant size, these technicians might not be needed for full time employment but can be called in when there is a specific problem regarding their field of work. Depending on the plant size an operations technician can manage multiple small units from the same control room. Because each of these professions can be spread out on multiple plants, and they can quickly be educated while the order of gas turbines or engines

is under way, the requirement for skilled labor is considered to be low, in comparison to other technologies.

P13: Possibility for camouflage and sheltering (R)

Gas turbines and engines have a small footprint, which means that they can easily be put into a bunker, that can be camouflaged. Therefore, the possibility for camouflage and sheltering is rated to be of high potential.

P14: Risk associated with fuel supply (R)

As Russia has invaded Ukraine and uses the gas supply as a leverage on European countries, the risk associated with gas as a fuel supply is considered as a medium level, because

European countries suddenly might not have any available gas to send to Ukraine via the gas lines. But Ukraine also has a considerable gas production, which they might utilize for the gas engines and turbines, but the fuel lines might be subjected to Russian terror which might lower the availability of gas for shorter periods of time, until the gas pipes have been fixed again. If the availability of gas is lowered, some gas engines or turbine plants might have to shut down for smaller periods of time.

If the gas engines utilize biogas, the risk associated with the fuel supply is expected to be low, as the biogas stems from Ukraine's own biogas facilities to which the engines are typically connected directly. The biogas facilities are expected to use agricultural waste products, which there is an abundance of in Ukraine.



Photovoltaics

Capacity
in wintertime



Implementation
speed



Technology
resilience



Levelized cost
of electricity



General Score:



PHOTOVOLTAICS

The rating on the frontpage shows the score for the technology achieving the highest general score among the sub technologies evaluated in the chapter. The more icons the better

performance⁴. For PV technologies it is the rooftop PVs that achieve the best score. The scores for all sub-technologies are shown in Table 9.

Criteria evaluation	2.a. PV residential rooftop	2.b.5.b PV comm. & industrial - with battery	2.b. PV comm. & industrial	2.c. PV utility scale, ground mounted	2.d. PV Utility scale, floating
Capacity in wintertime	W	W	W	W	W
Implementation speed	QQQ	QQQ	QQQ	QQ	QQ
Technology resilience	RRR	RRR	RRR	RR	RR
Levelized cost of electricity	C	C	C	C	C
General score (1-3)	2.0	2.0	2.0	1.5	1.5

Table 9: Photovoltaics - Overall criteria evaluation matrix

This chapter covers four different types of photovoltaic (PV) technologies:

- PV residential rooftop
- PV commercial, industrial, and public rooftop
- PV utility-scale
- Floating utility-scale PV

Firstly, a common brief technology description is explaining the fundamental technical details that is general for PV. Hereafter, each technology is outlined in individual subchapters

consisting of a brief technology description, criteria evaluation, and data sheet in annex F. The parameter evaluation for each technology, conversely, is conducted collectively, considering their shared similarities. Where possible a distinction between the technologies is made.

Brief technology description

Solar energy converts energy from sunlight to electricity with the help of photovoltaic panels consisting of solar cells. A solar cell is a semiconductor component that generates electricity

⁴ See detailed explanation in Table 2: Overview of which parameters contribute to which criteria and visualizing of the ratings, the more icons the better rating.

when exposed to solar irradiation. For practical reasons, several solar cells are typically interconnected and laminated to (or deposited on) a glass pane to obtain a mechanical ridged and weathering protected solar module.

In addition to PV modules, that are grid connected PV system or deliver to AC systems also includes Balance of System (BOS) consisting of a mounting system, DC to AC inverter(s), cables, combiner boxes, optimizers, monitoring/surveillance equipment and for larger PV power plants also transformer(s).

The photovoltaic (PV) modules are typically 1-2.5 m² in size and the best modules have a power capacity in the range of 220W/m² (and a technical efficiency around 22%). They are sold with a product warranty of typically ten to twelve years, a power warranty of minimum 25 years and an expected lifetime of more than 30 years depending on the type of cells and encapsulation method. There are no large new PV projects installed currently within the reach of Russian military actions, because there is no warranty against military damage.

Solar PV plants can be installed at the distribution (roof top of single-family houses and on the roof top of or in relation to commercial or public building), at transmission level (utility-scale PV or floating PV) or used off-grid applications.

The production pattern of solar PV makes the technology attractive to combine with a short time battery storage, for example lithium-ion batteries. While it would be clear cut to combine floating PV placed on dams of hydropower

plants with pumped hydro storage. Anyways all types of solar PV could be combined with storage batteries, but in this report only an example of combining the PV on commercial or public buildings with a lithium-ion battery.

To calculate the generalized power generation from PV, in different Ukrainian regions, a raster map covering all of Ukraine was used. The raster map originated from Global Solar Atlas⁵. The map is shown in Figure 9, it shows the expected annual PV generation in full load hours (FLH: MWh per MW installed capacity) in different regions of Ukraine. More details on the calculation methodology can be found in Appendix D.

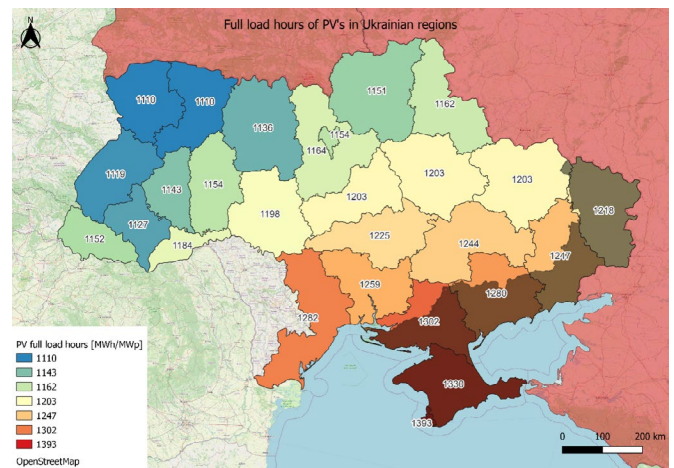

Figure 9: Expected PV generation (MWh per MW installed capacity) in different regions of Ukraine. An annual production of 1200 MWh/MW corresponds to a capacity factor of 14%. The maps are set up calculating the generalized power generation from photovoltaics, in the different Ukrainian regions, Global Solar Atlas covering the period between 1994-2018 was used.

⁵ <https://globalsolaratlas.info/map>

Overall assessment of the 4 criteria for PV

Solar PV technology offers significant generation potential and represents a scalable option for distributed energy generation which contributes positively to the resilience of the technology. In comparison to other renewable technologies, such as wind power and hydro, it boasts a relatively rapid development process, especially in the case of small-scale solar PV installations. However, when considering LCOE for the short lifetime and wintertime production PV exhibits one of the highest values, among all considered technologies. Regardless of providing one of the lowest LCOEs when calculated over the entire lifetime of energy production.

PV residential rooftop

Brief technology description

A PV residential rooftop refers to a solar PV system installed on the roof of a one family house. This system is designed to capture sunlight and convert it into electricity for on-site use or to feed back into the grid. It typically comprises of solar panels, inverters, grid connection and mounting structures, allowing homeowners to harness clean and sustainable energy from the sun to power their households. It is assumed that the total capacity of the PV modules in a residential system is up to 10kW.

Criteria evaluation	2.a. PV residential rooftop
Capacity in wintertime	W
Implementation speed	QQQ
Technology resilience	RRR
Levelized cost of electricity	C
General score (1-3)	2.0

Table 10: PV residential rooftop – criteria evaluation matrix

Winter impact (production at wintertime)

Solar PV generally produce more during summer-time than during the winter period⁶. Only 30% of the total production is in winter. The average capacity

factor during winter is app. 8%, while the annual capacity factor of 14%. The potential PV generation differs across the country which for wintertime production is shown on the map in Figure 10. This is consistent for PV technology and does not differ across various sub-technologies within the PV category.

Implementing speed (Q)

In principle a residential PV can be commissioned in less than 5 weeks after the decision has been taken. Since, it can be installed within a week. While the preparation processes including inspection and calculation to conclude if the construction of the roof is appropriate for installing the modules could also be conducted in a day or two. Furthermore, there will be a delivery time, which could also be assumed to be relatively short and less than 2 weeks. It is not necessary to include time spent obtaining permits, then, consumers can install electricity generation units for self-consumption without a license. However, it is possible to enter into agreements to get an active consumer status is achieved by signing electricity purchase and sale agreements under the self-generation mechanism, agreements with guaranteed buyers or universal service providers for selling electricity at a feed-in tariff, this will cost extra time but that is not necessary for bringing the residential PV plants in operation.

Resilience (R)

Residential PV showcase considerable resilience in the face of potential threats, such as Russian strikes, owing to their dispersed layout. Solar PV technology presents significant potential for decentralized energy production. In the current Ukrainian context, distributed solar PV installations located near demand offer advantage such as reduced dependence on the transmission grid, mitigating risks associated with potential power production capacity loss. Operation and maintenance of solar PV installations do not require exceptionally specialized workforce making it easier to gather Ukrainian teams to service solar installations.

⁶ October to March

Generation costs (LCOE), short term and over the lifetime (C)

Residential PV technology exhibits one of the least competitive Levelized cost of electricity (LCOE) when analyzed over the short term (2 years) and only for wintertime production. This is due to the high capital cost and low production in wintertime. Seen over the entire lifetime, the LCOE for PV is on the other hand among the lowest among the technologies analyzed.

Data sheet
In Appendix F

PV commercial and public, rooftop and ground mounted

Brief technology description

PV commercial and public, rooftop and ground

mounted refers to a solar PV system installed on the roof of or at the ground in relation to commercial or public buildings. This system is designed to capture sunlight and convert it into electricity for on-site use or to feed back into the grid. It typically comprises of solar panels, inverters, grid connections, mounting structures, monitoring equipment that tracks the performance of the PV installation. Scale and Capacity: PV on commercial, industrial, and public rooftops range from small-scale installations to large projects, depending on the energy demand and available space. It is assumed that the total capacity of the PV modules in a residential system is up to 100 kW.

A variation that is considered in this analysis is the combination of a PV and an energy storage (a lithium-ion battery) to store surplus electricity for use during periods of low sunlight or as a backup power source.

Criteria evaluation	2.b. PV comm. & industrial	2.b.5.b PV comm. & industrial - with battery
Capacity in wintertime	W	W
Implementation speed	QQQ	QQQ
Technology resilience	RRR	RRR
Levelized cost of electricity	C	C
General score (1-3)	2.0	2.0

Table 11: PV commercial, industrial, and public rooftop – criteria evaluation matrix

Winter impact (production at wintertime)

Solar PV typically generates more power in the summer compared to the winter period⁷, with only around 30% of the total production occurring in winter. However, the capacity factor varies between the regions. The average capacity factor during winter is approximately 8%, while the average annual capacity factor is 14%. This is consistent for PV technology and does not differ across various sub-technologies within the PV category.

Implementing speed (Q)

The development of a commercial-scale solar PV project involves several key steps, including conducting preliminary feasibility and roof/land inspections, and performing technical and economic feasibility studies. Conducting Technical and Economic Feasibility Study (TEFS) and Project and Cost Estimate Documentation (PCED) varies based on the need of detailed analysis required. It is common to do a PCED to start with. Tenders for construction are announced, leading to the

⁷ October to March

project’s operation and transfer to local municipal companies for ongoing maintenance.

The timeframe for solar PV installations varies based on factors such as manufacturer, model, and order volume, ranging from weeks to months. In commercial-scale solar projects, the feasibility study takes about 5-7 days, inspections around 10 days, TEFS approximately one month, and PCED about 1.5 months (up to 4 months in less favorable circumstances). In the tendering process, contractors are required to maintain necessary equipment in stock and ensure delivery within 7 days during the tendering process.

The duration of the installation is assumed to 3 to 4 weeks.

Summing up to a total implementing time of approximately a little more than 20 weeks.

Resilience (R)

Commercial and public PV showcase moderate resilience in the face of potential threats, such as Russian strikes, owing to their dispersed layout. Solar PV technology presents significant potential for decentralized energy production. In the current Ukrainian context, distributed solar PV installations located near demand offer advantage such as reduced dependence on the transmission grid, mitigating risks associated with potential power production capacity loss. Operation and maintenance of solar PV installations do not require exceptionally specialized workforce making it easier to gather Ukrainian teams to service solar installations.

Combining with batteries improves the resilience. Furthermore, the batteries can be installed underground and or be sheltered and camouflaged, despite a considerable demand for cooling.

Generation costs (LCOE), short term and over the lifetime (C)

Commercial and public scale PV technology exhibit among the least competitive Levelized

cost of electricity (LCOE) when analyzed over the short term (2 years) and only for wintertime production. This is due to the high capital cost and low production at wintertime. Seen over the entire lifetime, the LCOE for PV is on the other hand is among the lowest among the technologies analyzed.

Data sheet
In Appendix F

PV utility-scale

Brief technology description

PV utility-scale refers to large-scale PV solar power generation systems that are designed and deployed to supply electricity to utility companies or the electrical grid. PV utility-scale systems are characterized by their substantial solar panel arrays, typically covering several acres of land.

Criteria evaluation	2.c. PV utility scale, ground mounted
Capacity in wintertime	W
Implementation speed	QQ
Technology resilience	RR
Levelized cost of electricity	C
General score (1-3)	1,5

Table 12: PV utility-scale – criteria evaluation matrix

Winter impact (production at wintertime)

Solar PV typically generates more power in the summer compared to the winter period⁸, with only around 30% of the total production occurring in winter. However, the capacity factor varies between the regions. The average capacity factor during winter is approximately 8%, while the average annual capacity factor is 14%. This is consistent for PV technology and does not differ across various sub-technologies within the PV category.

⁸ October to March

Implementing speed (Q)

The implementation speed of a utility-scale solar PV is set to moderate. The development of a utility-scale solar PV involves several key steps, including, identifying potential sites, securing land rights, screening the electrical grid's capacity, designing, obtaining permits, negotiating power purchase agreements, securing financing, procuring equipment, and finally, construction and test operations. The steps before ordering and construction are assumed to take a little more than 1 year.

If experienced construction companies are available, the solar park can be constructed within a time frame of approximately 6 months. Challenges include delays in grid connection, shortage of skilled engineers, and transportation obstacles. The delivery time for solar PV modules is in general short, because they can be found in large numbers in warehouses in Europe. The delivery time of inverters and the rest of the installations varies but is in general short. The Ukraine's infrastructure could pose challenges, but because of the modular structure, no parts of event large PV plants need to be transported as special transport. Despite ongoing war, solar PV installations continue in Ukraine, emphasizing the need for a proficient workforce. Integration into the electricity grid requires well-developed infrastructure, facing challenges from attacks on the grid during the war with Russia.

However, it is concluded that the total period from idea to operation is a little less than 2 years.

Resilience (R)

The resilience of utility scale PV is assessed to be moderate. In the current Ukrainian context, distributed solar PV installations located near demand centers offer advantages such as reduced dependence on the transmission grid, mitigating risks associated with potential power production capacity loss. Localized power generation enhances energy security

by minimizing the need for extensive electricity transmission.

Operation and maintenance of solar PV installations do not require exceptionally specialized workforce making it easier to gather Ukrainian teams to service solar installations. The resilience could be increased by including at least a two-year mandatory service contracts within tender specifications.

During war, protective structures, shelters, camouflage, or underground bunkers can be employed to protect the transformer station, but the possibility for protecting the modules is limited, and it could be assumed that risk for that the utility scale PV plant is seen as a target is higher.

Generation costs (LCOE), short term and over the lifetime (C)

Utility scale ground mounted PV technology exhibits the least competitive Levelized cost of electricity (LCOE) when analyzed over the short term (2 years) and only for wintertime production. This is due to the high capital cost and low production in wintertime. Seen over the entire lifetime, the LCOE for PV is on the other hand is among the lowest among the technologies analyzed.

Data sheet
In Appendix F

PV floating utility-scale

Brief technology description

Floating utility-scale PV refers to large-scale photovoltaic solar installations that are situated on bodies of water, such as dams and reservoirs, using floating platforms. In case, they are placed on the surface of the dam of a hydro power plants, transformers and grid can be shared, which is an advantage for the economy. The key difference to ground mounted Utility scale PV system is the specially designed floating structures or platforms are used to support solar panels on the water's surface. If the PV could benefit from the

more diffuse radiation due to the reflection on the surface of the dam, have not yet been documented.

As for the ground mounted utility scale PV Floating solar installations are typically connected to the electrical grid, allowing the generated electricity to be distributed and utilized as needed. Inverter systems are employed to convert the direct current (DC) electricity generated by the solar panels into alternating current (AC) suitable for the grid.

Criteria evaluation	2.d. PV Utility scale, floating
Capacity in wintertime	W
Implementation speed	QQ
Technology resilience	RR
Levelized cost of electricity	C
General score (1-3)	1.5

Table 13: PV utility-scale floating - criteria evaluation matrix

Winter impact (production at wintertime)

Solar PV typically generates more power in the summer compared to the winter period⁹, with only around 30% of the total production occurring in winter. However, the capacity factor varies between the regions. The average capacity factor during winter is approximately 8%, while the average annual capacity factor is 14%. This is consistent for PV technology and does not differ across various sub-technologies within the PV category.

Implementing speed (Q)

The implementation speed of a floating utility-scale solar PV is set to moderate. The development of a floating utility-scale solar PV involves several key steps, including, identifying potential sites, securing land rights, screening the electrical grid’s capacity, designing, obtaining permits, negotiating power purchase agreements, securing financing, procuring equipment, and finally, construction and test operations. The steps before ordering and construction are assumed to

take a little more than 1 year.

Given that floating PV is a relatively new technology, it could be a challenge to find and hire experienced construction companies. Therefore, it is assumed that it may take slightly longer to construct a floating solar park than a ground mounted, but that it can still be completed within approximately 8 months. Challenges include delays in grid connection, shortage of skilled engineers, and transportation obstacles. The delivery time of inverters and the rest of the installations varies but is in general short. The Ukraine’s infrastructure could pose challenges, but because of the modular structure, no parts of event large PV plants need to be transported as special transport. Integration into the electricity grid requires well-developed infrastructure but could faster if placed on a dam of a hydro plant, where the installations sufficient capacity is already available. However, it is concluded that the total period from idea to operation is a little more than 2 years.

Resilience (R)

The resilience of floating utility scale PV is assessed to be moderate. In the current Ukrainian context, distributed solar PV installations located near demand centers offer advantages such as reduced dependence on the transmission grid, mitigating risks associated with potential power production capacity loss. Localized power generation enhances energy security by minimizing the need for extensive electricity transmission.

Operation and maintenance of solar PV installations do not require exceptionally specialized workforce making it easier to gather Ukrainian teams to service solar installations. The resilience could be increased by including at least a two-year mandatory service contracts within tender specifications.

During war, protective structures, shelters, camouflage, or underground bunkers can be employed to protect the transformer station, but the possibility for protecting the modules is limited,

⁹ October to March

and it could be assumed that risk for that the utility scale PV plant is seen as a target is higher than for the smaller PV systems.

Generation costs (LCOE), short term and over the lifetime (C)

Utility scale floating PV technology exhibits among the least competitive Levelized cost of electricity (LCOE) when analyzed over the short term (2 years) and only for wintertime production. This is due to the high capital cost and low production

in wintertime. Seen over the entire lifetime, the LCOE for floating PV is on the other hand is in the middle among the technologies analyzed.

Data sheet
In Appendix F

PV parameter evaluation

Due to their similarities the parameter evaluation covers all sub-technologies of the PV segment. Where possible a distinction is made.

Parameters	2.a. PV residential rooftop	2.b.5.b PV comm. & industrial - with battery	2.b. PV comm. & industrial	2.c. PV utility scale, ground mounted	2.d. PV Utility scale, floating
P1-Electricity production at wintertime	<30%	<30%	<30%	<30%	<30%
P2-Levelized Cost of Electricity (LCOE) short lifetime, winter production [€/MWh]	3200	4350	3050	2550	3150
P3-Levelized Cost of Electricity (LCOE) over lifetime [€/MWh]	71	95	68	60	63
P4-Distributed generation	0,006 MW	0,1 MW	0,1 MW	15 MW	10 MW
P5-Regulation requirement in the project development process	Quick and easy	Quick and easy	Quick and easy	In between	In between
P6-Delivery time and availability of components and materials	Quick and easy	Quick and easy	Quick and easy	In between	In between
P7-Requirements for logistics and transportation infrastructure	Low	Low	Low	Medium	Medium
P8-Technical installation time (after clearance)	Quick and easy	Quick and easy	Quick and easy	Quick and easy	Medium-term
P9-Requirements for skilled staff in construction phase	Low	Low	Low	Low	Low
P10-Grid balancing capacity	Low	Medium	Low	Low	Low
P11-Requirements for electricity grid infrastructure	Easy	Easy	Easy	Challenging	Challenging
P12-Requirements for skilled staff for operation and maintenance and for special spare parts	Low	Low	Low	Low	Low
P13-Possibility for camouflage and sheltering	High potential	High potential	High potential	Medium potential	Medium potential
P14-Risk associated with fuel supply	Low risk	Low risk	Low risk	Low risk	Low risk

Table 14: Photovoltaic technologies - parameter evaluation matrix. The LCOE unit is [€/MWh].

P1 Electricity production at wintertime:

Solar PV generally produce more during summertime than during the winter period¹⁰. Only 30% of the total production is in winter. The average capacity factor during winter is app. 8%, while the annual capacity factor of 14%. Obviously, the production depends on the specific location. Figure 10 shows, the expected annual wintertime PV generation in full load hours (FLH: MWh per MW installed capacity) in different regions of Ukraine.

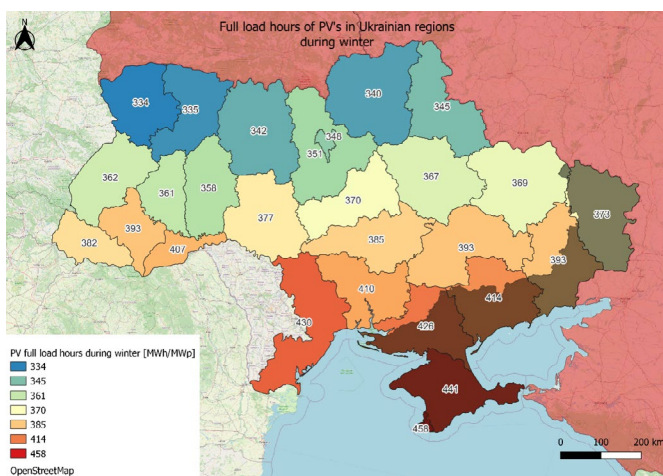

Figure 10 : Expected wintertime PV generation (MWh per MW installed capacity) in different regions of Ukraine. A wintertime production of 350 MWh/MW corresponds to app. 30 % of the annual production and a capacity factor of 8%. The maps are set up calculating the generalized power generation from photovoltaics, in the different Ukrainian regions, Global Solar Atlas covering the period between 1994-2018 was used.

P2: Levelized Cost of Electricity (LCOE) short lifetime, winter production (C)

The levelized cost of electricity generation over two winters (emergency perspective) amount to approximately:

- 3250 €/MWh for PV residential rooftop
- 4350 €/MWh for PV comm. & industrial - with battery

- 3050 €/MWh for PV comm. & industrial
- 2550 €/MWh for PV Utility-scale
- 3150 €/MWh for Floating PV

This is significantly higher than for all other technologies included in this analysis. This is due to the high upfront capital costs and the low production during winter.

P3: Levelized Cost of Electricity (LCOE) over lifetime (C)

On the other hand, solar PV technology shows low Levelized Cost of Electricity (LCOE) when considering production all year round and the project’s expected lifetime, which spans a minimum of 30 years, barring any unforeseen events:

- 70 €/MWh for PV residential rooftop
- 95 €/MWh for PV comm. & industrial - with battery
- 70 €/MWh for PV comm. & industrial
- 60 €/MWh for PV Utility-scale
- 65 €/MWh for Floating PV,

Which shows that LCOE over the lifetime of PV is in general lower than for all other technologies included in these analyzes, except for wind and hydro. Combining with batteries the LCOE increases by approximately 35%. The value of increasing the own consumption of the production from the PV by combining with a battery is not included in the LCOE calculation.

P4: Distributed generation (R)

Solar PV technology holds substantial generation potential as a scalable choice for decentralized energy production. Solar PV installations can vary in size, spanning from a few watts to multiple megawatts.

Given the current situation in Ukraine, there are several compelling reasons to favor distributed solar PV installations. These installations, located near demand centers, offer the

¹⁰ October to March

advantage of reducing dependence on the transmission grid, thereby mitigating the risks associated with potential power production capacity loss. Moreover, local power generation at the end-user's site diminishes the necessity for extensive electricity transmission, consequently bolstering energy security.

P5: Regulation requirement in the project development process (Q)

In general, if solar panels are installed on single-family dwellings and the production does not exceed the family's own consumption limits, it is not needed to seek approval or licensing.

The preparation processes for residential PV includes inspection and calculation to conclude if the construction of the roof is appropriate for installing the modules, which could also be conducted in a day or two. It is not necessary to include time spent obtaining permits, because consumers can install electricity generation units for self-consumption without a license. However, it is possible to enter into agreements to get an active consumer status is achieved by signing electricity purchase and sale agreements under the self-generation mechanism, agreements with guaranteed buyers or universal service providers for selling electricity at a feed-in tariff, this will cost extra time, but that is not necessary for bringing the residential PV plants in operation.

The development of a commercial-scale solar PV project typically involves the following steps:

1. Preliminary Feasibility Study: This involves a theoretical assessment of the potential for installing a station, based on basic energy consumption data, building photos, and other consumption-related information. It provides an initial evaluation of the necessary investment, project benefits, projected electricity production costs, and energy offset. The preliminary feasibility study could be conducted within 5-7 days.
2. Roof Inspection Report or Land Inspection Report: These reports are more comprehensive and typically funded by the city council or entity interested in acquiring the project. Certified engineers prepare these reports, ensuring that the structure can support the installation. This step is crucial to prevent unexpected expenses for structural modifications later in the process. Roof inspections typically take about 10 days to complete. For land inspections, the focus is on communication infrastructure and potential limitations, such as gas pipelines or other project-affecting factors.
3. Conducting a Technical and Economic Feasibility Study (TEFS) or Creating Project and Cost Estimate Documentation (PCED): The choice between these options depends on various factors. If there is certainty about available project funding, it is common to proceed directly to PCED. If a potential investor commits to funding the project regardless of potential additional factors, PCED may also be the starting point. However, if a more detailed analysis is required, the process begins with a TEFS. This involves an engineer conducting a thorough site inspection and performing detailed calculations based on various scenarios, accounting for factors such as panel quantity and electrical network quality. A TEFS could take about 1 month while PCED could take from 1.5 months to 4 months.
4. Announcing Tenders for Construction. It is considered that a 30-kW plant could be built within 7-10 days, and a 100kW plant in about 15-18 days if no critical issues arise. Subsequent documentation processes depend on the parties involved and how quickly they want to close the matter.

The development of a utility-scale solar PV farm typically involves the following steps:

1. Screening Phase: This initial phase entails assessing the capacity and availability of the electrical grid to connect the solar park to the power system. Grid integration

studies are conducted to ensure the grid can accommodate the injected power from the solar PV at the chosen connection point. The results of these grid studies are crucial before a solar power developer can commit to a specific project. Depending on the park's location, the wait time for grid connection can be substantial.

2. **Development Phase:** During this stage, potential sites for the solar park are identified, and the necessary land rights from landowners are secured, either through land purchase or leasing. It is recommended to engage in consultations with neighbours and discuss specific conditions relevant to PV installations to ensure local support before initiating political processes.
3. **Solar Park Design and Permitting:** This phase involves designing the layout and size of the solar park, as well as obtaining all the required permits and approvals from regulatory agencies. Environmental impact assessments (EIA) are not mandatory for solar power projects.
4. **Power Purchase Agreements:** This phase includes negotiating contracts with utilities or other off takers to sell the electricity generated by the solar park.
5. **Financing:** In this step, funding is secured from investors or lenders to cover the costs of developing, constructing, and operating the solar park.
6. **Procurement:** This phase involves acquiring or leasing all the necessary equipment, materials, and services for building and operating the solar park. The delivery time for new solar panels is typically less than 10 weeks, but for the transformer and inverters in some cases, it can extend up to two years. This phase also involves contracting with local construction companies for civil works, roads, construction sites, and electrical infrastructure.
7. **Construction and putting into Operations:** This phase encompasses the construction, testing, commissioning, and operation of the solar park over its lifetime. If experienced construction companies are available, the solar park can be constructed within a time frame of approximately 6 months.

To reduce the process for utility-scale solar farms, one effective approach is to commence with projects that have already undergone exhaustive due diligence.

P6: Delivery time / availability of components and materials (Q)

In general, PV modules are in stock on the market in EU, and thereby easily available. However, the delivery timeframe for solar PV installations in Ukraine can vary from a matter of weeks to several months, partly depending on the scale of the installation.

P7: Requirements for logistics and transportation infrastructure (Q)

The transportation of solar PV components, including panels, inverters and mounting equipment, do not in general require specialized vehicles, equipment, and routes, depending on the installation's size, while it in general can be divided in modules. Although, Ukraine's logistics and transportation infrastructure can present challenges for due to subpar road conditions in certain regions, port and crane damages, and security concerns in war-affected areas.

P8: Technical installation time (min time after clearance) (Q)

Construction and test operations: This phase encompasses the construction, testing and commissioning. If experienced construction companies are available, the solar park can be constructed within a time frame of approximately 6 months. While residential can be installed in less than a week and commercial / public plants in less than 3 weeks depending on the size.

P9: Requirements for skilled staff in construction phase (Q)

The construction of PV installations, necessitates a proficient workforce spanning multiple disciplines, including engineering,

project management, procurement, installation, commissioning, quality control, health and safety, and environmental protection. But not to the same extent as for large wind power.

However, the installation of mounting systems requires a certain level of expertise. Mentioned as an advantage is contracting experienced workforce not at least when it comes to putting up the mounting system.

Based on the previous experience with erecting about 6.6 GW of PV capacity it is expected that skilled staff will be available. Despite that it has been mentioned that the lack of qualified technical supervision experts for quality assessment of construction and installation is a challenge in Ukraine at the moment.

P10: Grid balancing capacity (R)

The grid balancing capacity for PV is low. However, PV plants may provide downregulation if generating or upregulation if not generating at maximum capacity. Usually, PV plants would operate at maximum capacity since this would maximize earnings in the power market under normal conditions. The PV could support the grid, by supplying electricity at distributed level near the consumers.

P11: Requirements for electricity grid infrastructure (R)

The integration of utility scale PV, into the electricity grid necessitates the presence of well-developed transmission and distribution lines, substations, balancing and ancillary services, as well as the implementation of smart grid technologies. It's crucial to note that Ukraine's electricity grid infrastructure has faced challenges, including attacks on its electricity infrastructure by missiles and drones from Russia during the ongoing war.

A significant aspect is the need for seamless

integration of solar energy into the power grid without overburdening it. Consequently, it becomes imperative to adopt a regional approach, precisely outlining the strategic deployment of solar energy, thus ensuring its effective and efficient incorporation into the national energy landscape. This approach shall aim to address the challenges of grid integration and coordinated planning for the sustainable growth of solar energy in Ukraine.

P12: Requirements for skilled staff for operation and maintenance and for special spare parts (R)

The operation and maintenance of solar PV installations typically do not demand an exceptionally skilled and specialized workforce, making it relatively straightforward to assemble a Ukrainian team capable of servicing the solar installation. However, it's important to emphasize that a security company is imperative to provide round-the-clock protection for the PV plant, as the risk of theft is considerably high, a challenge common to all PV (and hydro) installations in Ukraine.

In tender specifications, it is highly recommended to stipulate the inclusion of a mandatory service contract for at least the initial two years. Moreover, considering a service contract for professional maintenance beyond this period is also advisable. Presently in Ukraine, service technicians conduct bi-annual visits to solar installations, primarily to assess the quality of connections, ensure the absence of issues, and address any emerging concerns.

P13: Possibility for camouflage and sheltering (R)

It is not possible to camouflage or shelter utility scale PV due to their size, but it is possible to protect critical components such as transformer stations with fences and/or by establishing them underground in bunkers or by protecting them with concrete roofs.

The size and production of the residential and in some extent of the commercial and public PV is relatively low, thereby, the importance for the electricity system limited, therefore, the risk for these being enfiladed is assessed to be relatively low than for the larger plants.

The map provided below illustrates the potential reach of Russian artillery and close-range ballistic missiles (CRBM). It becomes evident that a substantial portion of Ukraine, with the exception of the central regions, falls within the CRBM range. Even in these relatively safer areas, the energy infrastructure remains susceptible to potential drone attacks or longer-range missile strikes. Notably, the maps (in the two figures below) also underscores that the central regions of Ukraine, which face a lower risk of Russian artillery or missile attacks, continue to offer reasonable electricity generation potential, even during the winter season.

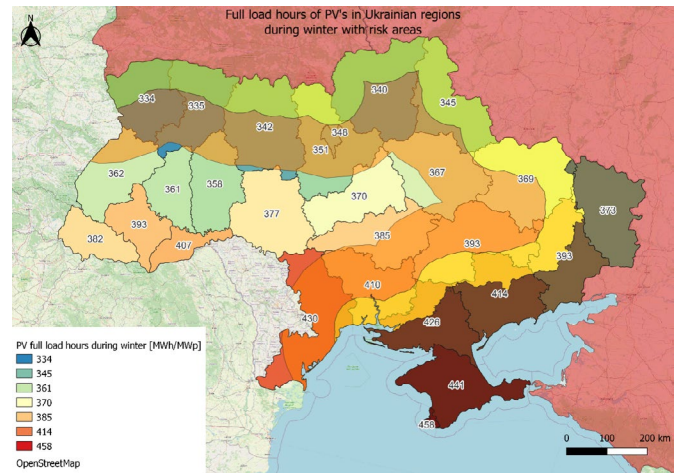

Figure 12: Expected wintertime PV generation (MWh per MW installed capacity) in different regions of Ukraine. And wintertime production of 350 MWh/MW corresponds to app. 30 % of the production and a capacity factor of 8%. Buffer zones of 100km and 280km was applied from Russian controlled areas and Belarus, accounting for the longest range of Russian artillery and CRBMs (close range ballistic missiles). The maps are set up calculating the generalized power generation from photovoltaics, in the different Ukrainian regions, Global Solar Atlas covering the period between 1994-2018 was used.

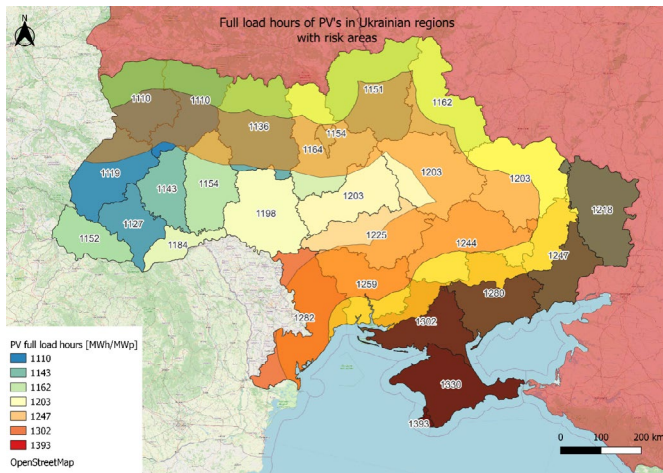

Figure 11: Expected annual PV generation (MWh per MW installed capacity) in different regions of Ukraine. An annual production of 1200 MWh/MW corresponds to a capacity factor of 14%. Buffer zones of 100km and 280km was applied from Russian controlled areas and Belarus, accounting for the longest range of Russian artillery and CRBMs (close range ballistic missiles). The maps are set up calculating the generalized power generation from photovoltaics, in the different Ukrainian regions, Global Solar Atlas covering the period between 1994-2018 was used.

P14: Risk associated with fuel supply (R)

Not relevant

Additional technology-specific insights from the interviews

Achieving a comprehensive large-scale transition towards green energy sources necessitates the attainment of cost competitiveness with conventional oil and gas alternatives. A pivotal factor in this transition involves the identification of reliable partners who possess bankable Power Purchase Agreements (PPAs).

According to insights from interviewed Ukrainian experts, the investment landscape in Ukraine is characterized by a scarcity of purely financial investments solely driven by

profit motives. Instead, stakeholders are often participants in co-financing endeavors, wherein they contribute equipment or financial resources, or provide support to Ukrainians in multifaceted ways. These contributors play an integral role in facilitating and advancing

sustainable projects within the Ukrainian landscape. E.g., the United Nations Development Programme on Energy service companies (UNDP ESCO) initiative's objectives aimed at enabling such investments¹¹.

¹¹ <https://www.undp.org/ukraine/publications/overview-best-practices-esco-market-design-and-recommendations-ukraine>

Onshore Wind

Capacity
in wintertime



Implementation
speed



Technology
resilience



Levelized cost
of electricity



General Score:



ONSHORE WIND

The rating on the frontpage shows the score for the technology achieving the highest general score among the sub technologies evaluated in the chapter. The more icons the better performance¹². For wind technologies it is the “used

onshore wind turbine farm” and the “household wind turbines” that achieve the best score. The scores for all sub-technologies are shown in Table 15.

Criteria evaluation	3.a. Wind onshore farms (>20MW)	3.b. Used wind onshore farms (>20MW)	3.c. Wind onshore cluster (4,2-20MW)	3.d. Wind household turbines (<100kW)
Capacity in wintertime	WW	WW	WW	WW
Implementation speed	Q	QQ	Q	QQQ
Technology resilience	RR	RR	RR	RRR
Levelized cost of electricity	CCC	CCC	CCC	C
General score (1-3)	2.0	2.3	2.0	2.3

Table 15: Wind Power - Overall criteria evaluation matrix

This chapter covers four different types of onshore wind technologies:

- Large-scale onshore wind farm (20-100 MW)
- Cluster of onshore wind turbines (5-20 MW)
- Used wind turbines for a large-scale onshore wind farm (20-100 MW)
- Household wind turbines

The three first technologies are all MW scale technologies, and their characteristics, challenges and opportunities are largely the same. Therefore, these technologies are treated together in most of the sections in the chapter.

Household wind turbines on the other hand are in the kW scale and intrinsically different from

¹² See detailed explanation in Table 2: Overview of which parameters contribute to which criteria and visualizing of the ratings, the more icons the better rating.

the large turbines, both regarding the technology and approval process, and are therefore considered in a separate chapter.

Onshore wind turbines (MW scale)

Brief technology description

Because of their similarities, this section covers large-scale onshore wind farm (20-100 MW), clusters of onshore wind turbines (5-20 MW) and used wind turbines for a large-scale onshore wind farm (20-100 MW).

The typical large onshore wind turbine being installed today is a horizontal axis, three bladed, upwind, grid connected turbine using active pitch, variable speed, and yaw control to optimize generation at varying wind speeds.

Wind turbines work by capturing the kinetic energy in the wind with the rotor blades and transferring it to the drive shaft. The drive shaft is connected either to a speed-increasing gearbox coupled with a medium- or high-speed generator, or to a low-speed, direct-drive generator. The generator converts the rotational energy of the shaft into electrical energy. In modern wind turbines, the pitch of the rotor blades is controlled to maximize power production at low wind speeds, and to maintain a constant power output and limit the mechanical stress and loads on the turbine at high wind speeds. A general description of the turbine technology and electrical system, using a geared turbine as an example, can be seen in Figure 13.

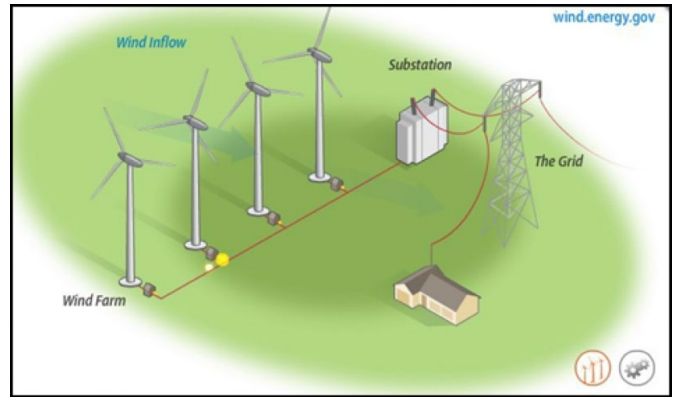

Figure 13 General wind turbine technology and electrical system

Three major parameters define the design of a wind turbine. These are hub height, nameplate capacity (or rated power) and rotor diameter. The last two are often combined in a derived metric called “specific power”, which is the ratio between nameplate capacity and swept area. The specific power is measured in W/m². At the beginning of 2020, the total installed capacity of Ukrainian wind farms was 1.17 GW. The wind resource in Ukraine is ample and studies have shown that Ukraine could potentially host more than 600 GW of wind capacity.



Figure 14 Four Vestas 3 MW wind turbines

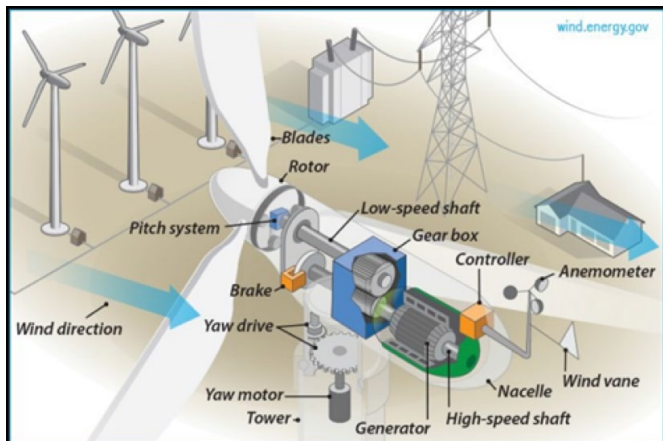

Figure 15 shows the expected annual wind turbine generation (MWh per MW installed capacity) in different regions of Ukraine. To calculate the generalized power generation from wind turbines, in different Ukrainian regions, a raster map covering all of Ukraine was used. The raster map originated from Global Wind Atlas. The raster map contains

the yearly capacity factor of wind turbines in the class IEC2¹³. More details on the calculation methodology can be found in Appendix E.

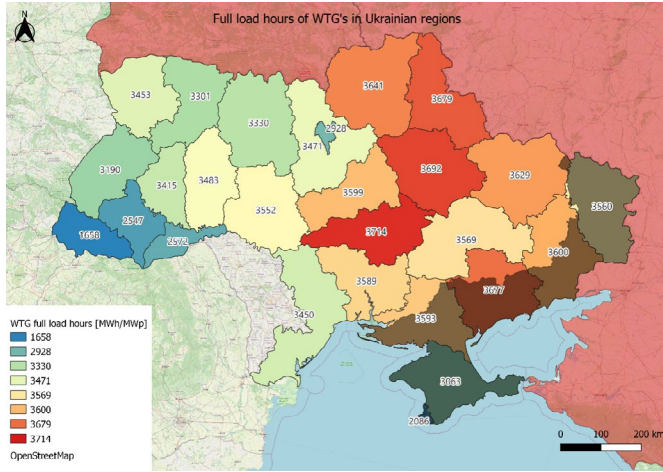

Figure 15: Wind resource chart, expected annual wind turbine generation (MWh per MW installed capacity) in different regions of Ukraine. An annual production of 3500 MWh/MW corresponds to a capacity factor of 40%.

Criteria evaluation

Large-scale onshore wind farm (20-100 MW)

Criteria evaluation	3.a. Wind onshore farms (>20MW)
Capacity in wintertime	WW
Implementation speed	Q
Technology resilience	RR
Levelized cost of electricity	CCC
General score (1-3)	2.0

Table 16: Wind Power - criteria evaluation matrix for Large-scale onshore wind farm (20-100 MW)

Winter impact, production at wintertime(W)

Large-scale onshore wind farm will be able to provide a significant contribution to the Ukrainian power system during wintertime. Obviously, the

production depends on the weather patterns and there will significant variations in generation over the winter season. However, Ukraine is a large country, and it is rarely calm everywhere. Large wind turbines demonstrate a capacity factor of about 40% during wintertime, meaning that on average 40% of the installed capacity can be utilized.

Implementing speed (Q)

In principle a wind farm may be erected within 6 months. However, the preparation processes are significant and involve environmental and legal permitting (1-2 years), delivery time for the wind turbines (up to two years) and feasibility studies and siting analyzes (about 1 year). Under ideal conditions and relaxed environmental approval procedures a green field wind farm project could be established within 2 years, but 4-5 years is a more realistic estimate for a large onshore wind farm given the current framework conditions in Ukraine.

Resilience (R)

Wind farms showcase considerable resilience in the face of potential threats, such as Russian strikes, owing to their dispersed layout. The transformer station connecting the wind farm to the high voltage power grid may be camouflaged or protected by a concrete ceiling. Therefore, it would require multiple attacks to take out a wind farm. Designing the wind farm with multiple 2-3 MW units, rather than fewer large units of perhaps 5-6 MW, would make the wind farm more resilient towards air strikes.

Generation costs (LCOE), short term and over the lifetime (C)

Large-scale wind farms exhibit one of the most competitive Levelized cost of electricity (LCOE)

¹³ IEC Class 1 turbines are generally for wind speeds greater than 8 m/s. These turbines are tested for higher extreme wind speed and more severe turbulence.

IEC Class 2 turbines are designed for average wind speeds of 7.5 m/s to 8.5 m/s.

IEC Class 3 turbines are designed for winds less than 7.5 m/s. These turbines will need a larger rotor to capture the same amount of energy as a similar turbine at a Class II site. Source: <https://www.lmwindpower.com/en/stories-and-press/stories/learn-about-wind/what-is-a-wind-class>

profiles among all available energy technologies. Even in the short term, involving the generation over just two winters, wind energy is fairly a cost-efficient option, despite its initial capital investment.

Cluster of onshore wind turbines (4,2-20 MW)

Criteria evaluation	3.c. Wind onshore cluster (4,2-20MW)
Capacity in wintertime	WW
Implementation speed	Q
Technology resilience	RR
Levelized cost of electricity	CCC
General score (1-3)	2.0

Table 17: Wind Power - criteria evaluation matrix for Cluster of onshore wind turbines (5-20 MW)

Winter impact (production at wintertime)

Onshore wind farm may provide a significant contribution to the Ukrainian power system during wintertime. The production depends on the weather patterns and there will show significant variations in generation, however, Ukraine is a large country, and it is rarely calm everywhere. Large wind turbines demonstrate a capacity factor of about 40% during wintertime, meaning that on average 40% of the installed capacity can be utilized.

Implementing speed

In principle a wind farm may be erected within 6 months. However, the preparation processes are significant and involve environmental and legal permitting (1-2 years), delivery time for the wind turbines (up to two years) and feasibility studies and siting analyzes (about 1 year). Under ideal conditions and relaxed environmental approval procedures a green field wind farm project could be established within 2 years, but 3-4 years is a more realistic estimate for a cluster of onshore wind turbines given the current framework conditions in Ukraine. Compared to large wind farms, up to 100 MW, it might be easier to site smaller projects at

locations where environmental and legal approval conditions are more favorable.

Resilience

Wind farms showcase considerable resilience in the face of potential threats, such as Russian strikes, owing to their dispersed layout. The transformer station connecting the wind farm to the high voltage power grid may be camouflaged or protected by a concrete ceiling. Therefore, it would require multiple strikes to take out a wind farm. Designing the wind farm with multiple 2-3 MW units, rather than a few large units of perhaps 5-6 MW, would make the wind farm more resilient towards air strikes. Generation costs (LCOE), short term and over the lifetime

Clusters of wind turbines are among the most competitive of all available energy technologies. Even in the short term, involving the generation over just two winters, wind energy is fairly a cost-efficient option, despite its initial capital investment.

Used wind turbines for a large-scale onshore wind farm (20-100 MW)

Criteria evaluation	3.b. Used wind onshore farms (>20MW)
Capacity in wintertime	WW
Implementation speed	QQ
Technology resilience	RR
Levelized cost of electricity	CCC
General score (1-3)	2.3

Table 18: Wind Power - criteria evaluation matrix for Used wind turbines for a large-scale onshore wind farm (20-100 MW)

Winter impact (production at wintertime)

Used wind turbines – typically 8-10 years old and with a capacity of 3 MW – applied in a large-scale (20-100 MW) wind farm may provide a significant contribution to the Ukrainian power system during wintertime. The production depends on the weather patterns and there will significant

variations in generation, however, Ukraine is a large country, and it is rarely calm everywhere. Large wind turbines demonstrate a capacity factor of about 40% during wintertime, meaning that on average 40% of the installed capacity can be utilized.

Implementing speed

In principle a wind farm may be erected within 6 months. However, the preparation processes are significant and involve environmental and legal permitting (1-2 years) and feasibility studies and siting analyzes (about 1 year). On the other hand, the delivery time for used wind turbines may, depending on the supplier, potentially be very short. Under ideal conditions and relaxed environmental approval procedures a green field wind farm applying used wind turbines project could be established within 1,5-2 years, but 3-5 years is a more realistic estimate given the current framework conditions in Ukraine.

Resilience

Wind farms showcase considerable resilience in the face of potential threats, such as Russian

strikes, owing to their dispersed layout. Since the transformer station connecting the wind farm to the high voltage power grid may be camouflaged or protected by a concrete ceiling, it would require multiple attacks to take out a wind farm. The upfront cost of a wind farm applying used wind turbines could be 30-40% lower than with new turbines, meaning less capital is at stake if the wind farm is attacked.

Generation costs (LCOE), short term and over the lifetime

Measured over their technical lifetime, wind turbines are among the most competitive of all available energy technologies – and this is also the case for used wind turbines, which can be expected to showcase LCOE's equivalent to new turbines. In the short term, involving the generation over just two winters, used wind turbines are more cost-efficient than new turbines, owing to their initial investment costs, but still higher than for example gas turbines or gas engines.

Parameter evaluation of onshore wind turbines

Parameters	3.a. Wind onshore turbines, farms (>20MW)	3.b. Used wind onshore turbines, farms (>20MW)	3.c. Wind onshore cluster (4,2-20MW)
P1-Electricity production at wintertime	50%	50%	50%
P2-Levelized Cost of Electricity (LCOE) short lifetime, winter production [€/MWh]	808	568	927
P3-Levelized Cost of Electricity (LCOE) over lifetime [€/MWh]	36	35	40
P4-Distributed generation	>20 MW	>20 MW	4,2-20 MW
P5-Regulation requirement in the project development process	Lengthy	Lengthy	Lengthy
P6-Delivery time and availability of components and materials	In between	Quick and easy	In between
P7-Requirements for logistics and transportation infrastructure	High	High	High
P8-Technical installation time (after clearance)	Medium-term	Medium-term	Medium-term
P9-Requirements for skilled staff in construction phase	Medium	Medium	Medium
P10-Grid balancing capacity	Medium	Medium	Medium
P11-Requirements for electricity grid infrastructure	Moderate	Moderate	Moderate

Parameters	3.a. Wind onshore turbines, farms (>20MW)	3.b. Used wind onshore turbines, farms (>20MW)	3.c. Wind onshore cluster (4,2-20MW)
P12-Requirements for skilled staff for operation and maintenance and for special spare parts	Medium	Medium	Medium
P13-Possibility for camouflage and sheltering	Medium potential	Medium potential	Medium potential
P14-Risk associated with fuel supply	Low risk	Low risk	Low risk

Table 19: Wind Power - parameters evaluation matrix for onshore (MW scale). The LCOE unit is [€/MWh].

Due to their similarities the quantitative parameter covers large-scale onshore wind farm (20-100 MW), clusters of onshore wind turbines (5-20 MW) and used wind turbines for a large-scale onshore wind farm (20-100 MW). Household wind turbines are evaluated in a separate section.

P1: Electricity production at wintertime (W)

The wind map shows that onshore wind turbines typically produce the same during winter and summer time, demonstrating a capacity factor of about 40%. Obviously, the production depends on the specific location. The abovementioned capacity factors assume that the wind turbines are erected in central and southern Ukraine, where the best wind conditions are found.

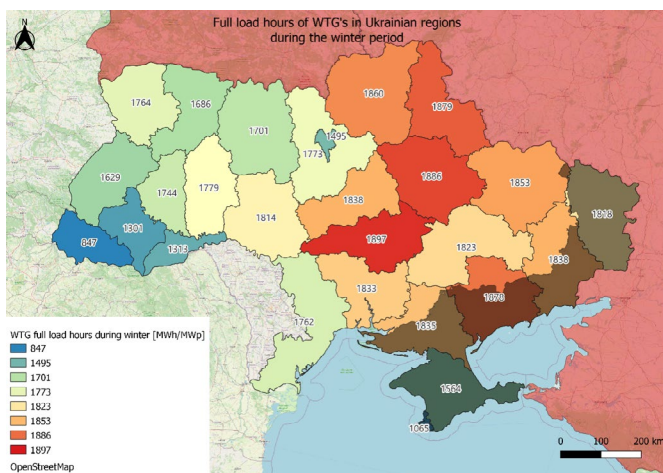

Figure 16: Expected Wind turbine generation (MWh per MW installed capacity) in different regions of Ukraine during wintertime (which in this context is defined as October-March, 4374 hours in total).

P2: Levelized Cost of Electricity (LCOE) short lifetime, winter production (C)

The levelized cost of electricity generation over two winters (emergency perspective) amounts to about 810 €/MWh for a large wind farm (20-100 MW) and slightly higher, about 830 €/MWh for wind farm up to 20 MW. This is significantly higher than for gas engines or gas turbines, which demonstrate costs down to around 300-400 €/MWh but still significantly less than for example solar technologies, batteries and certain biomass technologies.

The winter LCOE of used wind turbines could be about 30% lower than for new turbines due to lower upfront capital costs.

P3: Levelized Cost of Electricity (LCOE) over lifetime (C)

Large onshore wind farms (20-100 MW) demonstrate low LCOEs over lifetime of around 35 €/MWh over the lifetime of the turbines, which is minimum 25 years in absence of unexpected events. Since scaling effects are moderate, the LCOE of wind turbines in smaller clusters up to about 20 MW, is only expected to be about 10% higher.

The LCOE of used wind turbines is not expected to differ considerably from the LCOE of new turbines since the lower upfront capital costs are offset by shorter expected lifetime and (potentially) higher operation and maintenance costs.

P4: Distributed generation (R)

Onshore wind turbines are distributed over a relatively large area. Modern onshore wind turbines have installed capacity of 3 MW to 6 MW, and they are typically sited with a distance of between 300 to 500 meters depending on the size of the individual turbines. The fact that the turbines are spread over a large geographic area makes them less vulnerable to air strikes by artillery, missiles or drones.

P5: Regulation requirement in the project development process (Q)

The development of an onshore wind farm typically involves eight steps:

1. **Prospecting and land securing:** This phase involves identifying potential sites for the wind farm and securing the necessary land rights from landowners. Since modern wind farms cover a large area with multiple landowners, this can be quite complicated. The prospecting would also involve analysis of soil conditions. In total technical feasibility studies, excluding wind resource assessments, would take about 6 months to complete.
2. **Wind-resource assessment:** This phase involves measuring the wind speed and direction at the site to determine the potential energy output of the wind farm. Wind measurement may take about a 1 year to be sufficiently reliable. However, the Ukrainian Wind Energy Association expect that by February 2024 an electronic wind atlas will be ready covering on and offshore wind. The atlas is prepared in cooperation with NREL and is based on measurements at heights of 100-120 meters. The atlas could replace the need for physical measurements at site. Whether digital assessments are sufficient would often depend on the specific conditions set by the financing parties.
3. **Interconnection and transmission studies:** This phase involves evaluating the capacity and availability of the electrical grid to connect the wind farm to the power system.
4. **Wind-farm design and permitting:** This phase involves designing the layout, size, and number of wind turbines, as well as obtaining all necessary permits and approvals from regulatory agencies. The Ukrainian Wind Energy Association estimates that for large wind farms the process of obtaining environmental permits will take about three years. This includes ornithological studies, bat studies, ecological surveys, and geological research. The requirements for environmental impact assessments (EIA) have been slightly relaxed during the state of war. The ornithological studies, however, have not been changed, and they take a minimum of one year. Other deadlines, such as hearings where interested parties can submit comments to specific projects, have been shortened by about half or one-third.
5. **Power purchase agreements:** This phase involves negotiating contracts with utilities or other off takers to sell the electricity generated by the wind farm.
6. **Financing:** This phase involves securing funding from investors or lenders to cover the costs of developing, constructing, and operating the wind farm.
7. **Procurement:** This phase involves purchasing or leasing all necessary equipment, materials, and services for building and operating the wind farm. Delivery time for new wind turbines is typically one year, in some cases up to two years. This phase involves contracting contracts with local construction companies for civil works, roads, construction sites and electrical infrastructure
8. **Construction and operations:** This phase comprises building, testing, commissioning, and operating the wind farm over its lifetime. The wind farm may be constructed within a time horizon of 6 months if experienced construction companies are available.

The process of developing a wind farm is expected to be more or less the same independently of the size of the wind farm and whether new or used turbines are applied.

P6: Delivery time / availability of components and materials (Q)

The delivery time for onshore wind turbines depends on the manufacturer, the model, and the order volume. It can range from six months to two years.

However, it is worth noting that used wind turbines can be supplied on short notice. Used wind turbines would typically be around 8-10 years old and have a capacity of about 3-4 MW. There is a mature market for used turbines, and it is deemed realistic that at least 100 MW of used wind power capacity from Europe may be procured.

Ukrainian stakeholders in the wind industry have expressed concerns about using used wind turbines for different reasons: potentially more expensive spare parts, reliability of the turbines, lack of knowledge about how to service the old turbines. Therefore, it is important that any used turbines sold at the Ukrainian market are supplied with long-term guarantees or service contracts.

The overall time required for project's delivery depends on many factors such as size, complexity, access to grid, regulatory framework procedures etc. A typical renewable energy project such as an onshore wind farm may take three to five years to realize from planning to operation.

As a best estimate, developing a green field project in Ukraine would require minimum two years even if used wind turbines are applied, electronic wind speed measurements are available, and the project may be exempt from a lengthy environmental impact assessment process. Under less favorable conditions the total process may take up to five years.

If it is possible to resurrect wind farm projects already in process, but closed down or mothballed due to the war, this could allow for speedier project delivery.

The size of the wind farm, whether we are talking of a small-scale cluster of wind turbines up to 20 MW or are large scale farm of up to 100 MW, in itself has limited impact on the time for project delivery. However, it might be easier to site smaller projects at locations where environmental and legal approval conditions are more favorable.

P7: Requirements for logistics and transportation infrastructure (Q)

The transportation of onshore wind turbines requires special vehicles, equipment, and routes. The logistics and transportation infrastructure in Ukraine may pose some challenges for renewable energy development due to poor road conditions in some areas, damages to ports and cranes, and security risks in war areas. Transportation through Poland is feasible by road but challenging due to expensive and oversized components. However, when one gets closer to Central Ukraine, the issue becomes more complicated. There is an example of a company that during the war, managed to transport all the wind turbines through Poland.

The ports have been heavily damaged, and shipments that used to come through Denmark and Germany via the Black Sea have become nearly impossible.

Ensuring access to adequate transport infrastructure may be a critical parameter in the process of identifying sites for wind farms.

Communication infrastructure (preferably through optical fibers) is required to control the wind turbines from a distance.

P8: Technical installation time (min time after clearance) (Q)

Less than one year. If experienced construction companies are present, a large-scale wind farm (20-100 MW) may be constructed within a time horizon of 6 months.

P9: Requirements for skilled staff in construction phase (Q)

The construction of renewable energy projects such as onshore wind farms requires skilled staff in various fields, such as engineering, project management, procurement, installation, commissioning, quality control, health and safety, and environmental protection. Based on the previous experience of erecting about 1.17 GW of wind capacity it is expected that skilled staff will be available. Three wind farms have been constructed in Ukraine during the war.

Before the war, steel for the towers could be produced in Mariupol but this is obviously no longer an option, and therefore these components have to sources from elsewhere, for example Turkey, Poland, or other countries.

P10: Grid balancing capacity (R)

The integration of renewable energy sources such as onshore wind power into the electricity grid requires adequate transmission and distribution lines, substations, balancing and ancillary services, and smart grid technologies. The electricity grid infrastructure in Ukraine has been facing attacks on its electricity infrastructure by missiles and drones from Russia during the war. According to Ukrenergo, wind turbines are comparatively easy to integrate in the electricity grid because turbines are scattered across Ukraine and typically produce for several days in a row.

Wind turbines may contribute to the security of supply at regional level during situations with widespread power outages when critical transmission infrastructure and/or power plants are down. During December 2022, when there was a blackout, part of the Odesa region had electricity thanks to the work of three wind power stations.

In some regions there is electricity surplus, i.e. despite the war, there is more electrical capacity than required. Therefore, the state of the electricity grid should be factored in, as a criterion in the localization of new wind farms.

P11: Requirements for electricity grid infrastructure (R)

The electricity grid is considered robust enough to accommodate the integration of onshore wind power, and there are ample wind sites located at a reasonable distance from the grid. This ensures that wind projects should not encounter excessive challenges in connecting to the grid.

P12: Requirements for skilled staff for operation and maintenance and for special spare parts (R)

The operation and maintenance of renewable energy projects such as onshore wind farms require skilled staff in various fields such as monitoring, troubleshooting, repair, inspection testing cleaning optimization etc. The availability of skilled staff in Ukraine may be limited by factors such as lack of training programs or migration of qualified workers. Based on the previous experience of erecting about 1.7 GW of wind capacity it is expected that skilled staff will be available. Ukrainian Wind Energy Association hosts two service companies, Firewind and Enerproof.

P13: Possibility for camouflage and sheltering (R)

It is not possible to camouflage or shelter individual onshore wind turbines due to their size, but it is possible to protect critical components such as transformer stations with fences and/or by establishing them underground in bunkers or by protecting them with concrete roofs.

The map below shows the potential ranges of Russia artillery and close-range ballistic missiles (CRBM). It appears that a large part of Ukraine, with exception of the central and southeastern part, is within the range of CRBMs and even in these areas, energy infrastructure could potentially be struck by drones or longer-range missiles. The map also shows that the regions in central Ukraine, which are at least risk of being hit by Russian artillery or

missiles, demonstrate a high electricity generation potential during wintertime.

The risk associated with operation almost entirely relate to the risk of Russian attacks on the facilities. Due to the dispersed nature of the energy assets these risks are deemed to be fairly low, also considering that until now only about 10 wind turbines have suffered damage from the war. Transformer stations demonstrate good opportunities for protection through sheltering and camouflage.

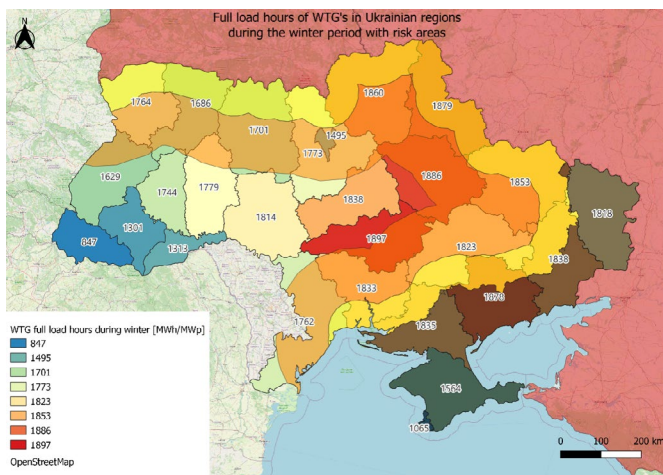

Figure 17: Expected wintertime wind turbine generation (MWh per MW installed capacity) in different regions of Ukraine during wintertime (which in this context is defined as October-March, 4374 hours in total) along with an indication of the range of Russian artillery and close-range ballistic missiles.

P14: Risk associated with fuel supply (R)

Not a relevant risk for wind turbines.

Additional technology-specific insights from the interviews

Foreign investors such as IBRD (The International Bank for Reconstruction and Development (IBRD), IFC (International Finance Cooperation) have stated that they are willing to invest during the war, but with one condition. They will invest and provide loans exclusively to foreign companies because it is easier to insure any risks with

foreign companies. Moreover, they expect support from the Ukrainian government in developing the projects, along with an insurance fund that would cover military risks.

Foreign renewable energy developers have suggested that fast development of wind turbine farms could be ensured if the state provided sites and building permits for them through expropriation or voluntary agreements with landowners.

The Ukrainian Wind Energy Association asserts that the policy of the National Energy and Utilities Regulatory Commission (NEURC), especially regarding making all RES producers with a capacity of > 1 MW responsibility for their imbalances. This could be seen as a hindering for the development of not only the wind sector but also solar energy.

Household wind turbines

Brief technology description

Household wind turbines have installed capacity of 0,5-25 kW, with a rotor swept area smaller than or equal to 200 m² and max. height of 25 m, generating electricity at a voltage below 1 000 V AC or 1 500 V DC

Household wind turbines are commonly cited close to buildings in residential areas. By Ukrainian law it is allowed to install household wind turbines with a capacity of up to 50 kW in private households. For the proper placement of household wind turbines, it is important to maintain a suitable distance, from the nearest neighbor. Small wind turbines can produce noticeable noise owing to their rapid rotations and high operating speed.

The capacity factor of small wind turbines varies a lot depending on the local conditions. The wind turbines are often located close to buildings and trees, which will reduce the annual production from the wind turbines because of turbulence from buildings and trees. The specific output power will, as with the larger turbines, have an impact on the capacity factor and so have the relative low hub

height. Household wind turbines can use generated electricity for in-house consumption, in addition to exporting power to the utility grid.



Figure 18 ANTARIS 2.5 kW household wind turbines

Criteria evaluation of household wind turbines

Criteria evaluation	3.d. Wind household turbines (<100kW)
Capacity in wintertime	WW
Implementation speed	QQQ
Technology resilience	RRR
Levelized cost of electricity	C
General score (1-3)	2.3

Table 20: Wind Power - criteria evaluation matrix for Household wind turbines.

Winter impact (production at wintertime)

Household wind turbines will be able to provide electricity to individual households and the power system during wintertime. The production depends on the weather patterns, according to analyzed data for Ukraine 51% of the full load hours occurred during the cold period (see Figure 16) Indicating that the wind turbines maintain a relatively steady level of electricity generation all year around.

Implementing speed

The overall process is estimated to take approximately four to five months from the initial

planning stages to the commissioning of the household wind turbine in Ukraine.

Planning and building a household wind turbine in Ukraine involve a relatively shorter and less complex regulatory process compared to larger onshore turbines. Delivery of components is expected to be the most time-consuming activity and is estimated to take approximately three months.

Once on-site, the technical installation time takes about 1-2 months, involving heavy machinery like excavators and cranes. After laying foundations, a waiting period of 2-6 weeks is necessary for the concrete base to cure. The actual installation process, including assembling the tower, generator, blade, and control panel, takes up to two days. Skilled staff from a specialized company are required for the installation and commissioning phases.

Resilience

A household wind turbine might be considered less likely to be a target for potential threats, such as Russian strikes, given its smaller size. Similar to rooftop PVs, these turbines offer advantages in terms of location and distribution. Placed near the demand points, they reduce reliance on the transmission grid, thus lowering the risks associated with potential power capacity loss. Furthermore, localized power generation at the user’s site reduces the need for extensive electricity transmission, contributing to enhanced energy security.

Generation costs (LCOE), short term and over the lifetime

Over two winters, from an emergency perspective, the LCOE for a household wind turbine amounts to approximately 2600 €/MWh, notably higher than larger onshore wind turbines but comparable to residential rooftop PVs. Looking at the lifetime perspective (20 years), LCOE of around 170 €/MWh

of household wind turbines, is considered medium height compared to the alternatives investigated in this technology catalogue.

Parameter evaluation household wind turbines

In summary, household wind turbines in Ukraine offer steady electricity generation,

with advantages in distribution, regulatory processes. Their smaller size may also enhance resilience to potential threats. The LCOE over two winters is around 2800 €/MWh, which is more than three times the cost per MWh as larger onshore wind turbines but comparable to residential rooftop PVs. Over the lifetime, household wind turbines demonstrate a LCOE of around 180 €/MWh.

Parameters	3.d. Wind household turbines (<100kW)
P1-Electricity production at wintertime	50%
P2-Levelized Cost of Electricity (LCOE) short lifetime, winter production [€/MWh]	2795
P3-Levelized Cost of Electricity (LCOE) over lifetime [€/MWh]	177
P4-Distributed generation	0,1 MW
P5-Regulation requirement in the project development process	Quick and easy
P6-Delivery time and availability of components and materials	Quick and easy
P7-Requirements for logistics and transportation infrastructure	Low
P8-Technical installation time (after clearance)	Quick and easy
P9-Requirements for skilled staff in construction phase	Medium
P10-Grid balancing capacity	Medium
P11-Requirements for electricity grid infrastructure	Easy
P12-Requirements for skilled staff for operation and maintenance and for special spare parts	Low
P13-Possibility for camouflage and sheltering	High potential
P14-Risk associated with fuel supply	Low risk

Table 21: Wind Power - parameters evaluation matrix for onshore household turbines (kW scale). The LCOE unit is [€/MWh].

P1: Electricity production at wintertime (W)

According to analyzed data for Ukraine 51% of the full load hours occurred during the cold period (see Figure 16). Indicating that the wind turbines maintain a relatively steady level of electricity generation, regardless of the season.

P2: Levelized Cost of Electricity (LCOE) short lifetime, winter production (C)

The levelized cost of electricity generation over two winters (emergency perspective) amounts to about 2800 €/MWh for a household wind turbine. This is significantly higher than for larger

onshore wind turbines. The cost is approx. at the same level as residential rooftop PVs.

P3: Levelized Cost of Electricity (LCOE) over lifetime (C)

Household wind turbines demonstrate medium LCOEs of around 180 €/MWh over the lifetime of the turbines, which is minimum 20 years in absence of unexpected events.

P4: Distributed generation (R)

Household wind turbines have similar benefits, regarding location and distribution, as rooftop

PVs. The installations, located near demand, offer the advantage of reducing dependence on the transmission grid, thereby mitigating the risks associated with potential power production capacity loss. Moreover, local power generation at the end-user's site diminishes the necessity for extensive electricity transmission, consequently bolstering energy security.

P5: Regulation requirement in the project development process (Q)

It is worth noting that the regulatory process for household wind turbines is often shorter and less complex than that of larger onshore wind turbines. In Ukraine it is also easier to get permission to set up used household wind turbines, as they do not have to undergo the same lengthy project development process as larger wind turbines.

P6: Delivery time / availability of components and materials (Q)

The delivery time for a household wind turbine in Ukraine is estimated to be approx. three months. Before the war, steel for the towers could be produced in Mariupol but this is no longer an option, and therefore these components have to sources from elsewhere, for example Turkey, Poland, or other countries.

P7: Requirements for logistics and transportation infrastructure (Q)

It is important that there is good access to the installation site for a truck, i.e., a wide road with sufficient load bearing capacity.

P8: Technical installation time (min time after clearance) (Q)

The technical installation time for a household wind turbine is approx. 1-2 months. The installation process for a wind turbine system may require the use of heavy machinery such as an excavator and crane, depending on the size and type of the turbine. Additionally, it is typically necessary to wait for 2-6 weeks after

the laying of foundations to allow the concrete base to cure. After the base is cured the wind-mill is erected. The tower, generator, blade, and control panel are delivered and assembled, and the mill is commissioned. The installation work can take up to two days.

P9: Requirements for skilled staff in construction phase (Q)

To install a household wind turbine a specialized company is required to perform the installation and commissioning.

P10: Grid balancing capacity (/demands) (R)

Household wind turbines can, in the same way as larger wind turbines, be used for downregulation, where wind turbines are switched off when there is a surplus of electricity in the electricity grid and a need for downward regulation. If weather conditions permit energy production, wind turbines from a downregulated state can be relatively easily brought back to an upregulated state.

Wind turbines may also contribute to the security of supply during situations with widespread power outages when critical transmission infrastructure and/or power plants are down.

P11: Requirements for electricity grid infrastructure (R)

The electricity grid is considered robust enough to accommodate the integration of the amount of energy supplied by household wind turbines.

P12: Requirements for skilled staff for operation and maintenance and for special spare parts (R)

Regular servicing, repair, and maintenance of all wind turbines are essential to prevent any potential hazards to the safety and well-being of both humans and animals. Wind turbine servicing must be conducted by an authorized or certified service provider.

P13: Possibility for camouflage and sheltering (R)

It is not possible to camouflage or shelter individual onshore wind turbines due to their size, but it is possible to protect critical components such as transformer stations with fences and/or by establishing them underground in bunkers

or by protecting them with concrete roofs. A household wind turbine might be considered less likely to be a target for potential threats, such as Russian strikes, given its smaller size.

P14: Risk associated with fuel supply (R)

Not a relevant risk for wind turbines.



Batteries

Capacity
in wintertime



Implementation
speed



Technology
resilience



Levelized cost
of electricity



General Score:

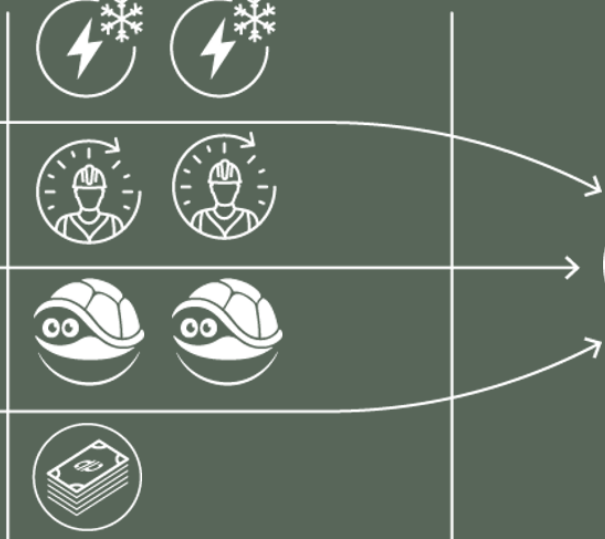

BATTERIES

The rating on the frontpage shows the score for the technology achieving the highest general score among the sub technologies evaluated in the chapter. The more icons the better

performance¹⁴. For Li-ion batteries, it is the “Li-ion batteries community scale” that achieve the best score. The scores for all sub-technologies are shown in the table below.

Criteria evaluation	5.a. Bat, Li-Ion Utility scale	5.b. Bat, Li-Ion community scale
Capacity in wintertime	WW	WW
Implementation speed	QQ	QQQ
Technology resilience	RR	RR
Levelized cost of electricity	C	CC
General score (1-3)	1,8	2,3

This chapter covers lithium-ion batteries (LIB) of two different sizes:

- Grid-scale batteries, (capacity app. 1-150MW, energy storage 2-500 MWh)
- Community batteries (capacity app. 40-500 kW, energy storage 40-600kWh)

With increasing shares of renewable energy in power systems, the role of electricity storage grows in importance. Batteries could also be relevant as distributed electricity storages in

places, especially where there is no access to the existing pumped hydro storages. The demand could be covered by pumped hydro storage¹⁵ which is already available in Ukraine.

Furthermore, batteries have experienced notable cost declines in the past years. This is especially true for certain LIB types. Lithium-ion batteries (LIB) have completely dominated the market for grid scale energy storage solutions in the last 5-8 years and appear to be the

¹⁴ See detailed explanation in Table 2: Overview of which parameters contribute to which criteria and visualizing of the ratings, the more icons the better rating.

¹⁵ e.g., hydro power with dams, including the facility to pump hydro from lower to higher reservoirs

dominating battery solution. For this reason, this chapter focuses on LIB.

Brief technology description

A typical LIB installed nowadays has a graphitic anode, a lithium metal oxide cathode and an electrolyte that can be either liquid or in (semi-) solid-state. LIB commonly comes in packs of cylindrical cells and can reach energy densities of up to 300 Wh/kg. The battery required an area around 5 m²/MWh.

The potential applications of batteries in electricity systems are very broad, ranging from supporting weak distribution grids, e.g., with frequency regulation and black-starting to the

provision of bulk energy services or off-grid solutions.

To understand the services batteries can provide to the grid, Rocky Mountain Institute performed a meta-study [2] of existing estimates of grid and customer values by reviewing six sources from across academia and industry. The study’s results illustrated that energy storage can provide a suite of thirteen general services to the electricity system (see Figure 19). These services and the value they create generally flow to one of three stakeholder groups: customers, utilities, or independent system operators/regional transmission organizations (ISO/RTOs).

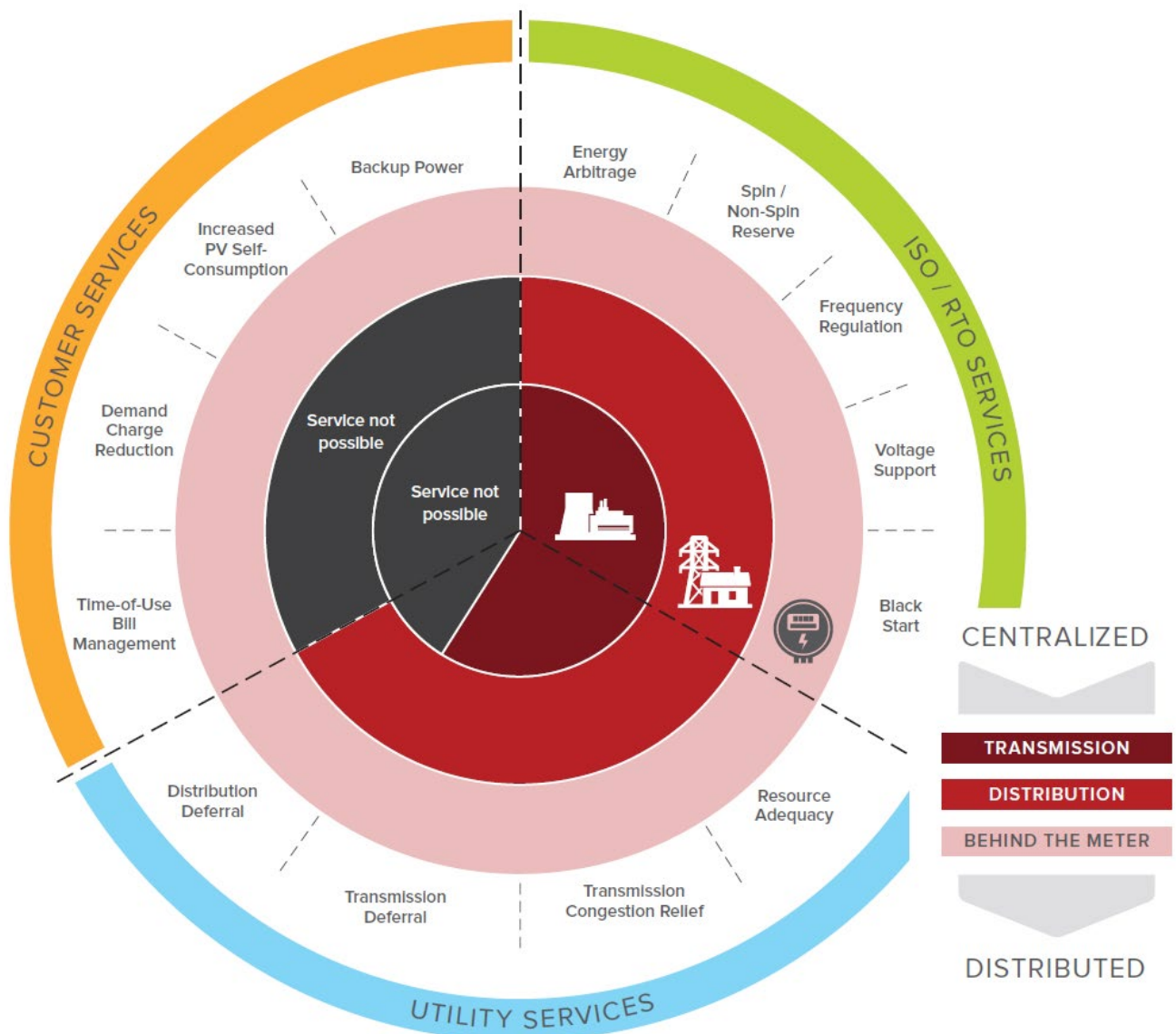

Figure 19: Services LIB can provide to different stakeholder groups [2]

This technology description focuses on batteries for provision of bulk energy services and customer energy management services, i.e., time-shift over several hours (arbitrage)— for example moving PV generation from day to night hours –, the delivery of peak power capacity, demand-side management, power reliability and quality.

In order to fully capitalize on the benefits of LIB storage in the grid, the implementation of dispatching strategies with frequent intervals such as hourly or 15 minutes planning is recommended to get the full benefit of the batteries.

Grid-scale batteries

Brief technology description

Grid-scale batteries are a type of energy storage technology that can store large amounts of

electricity for later use. They can help balance the supply and demand of electricity, especially when there is a high penetration of renewable energy sources, such as wind and solar, that are variable and intermittent. Grid-scale batteries can also provide other benefits to the power system, such as frequency regulation, voltage support, peak shaving, and black start capability.

A schematic overview of a battery system and its grid connection can be seen in Figure 20. A Thermal Management System (TMS) controls the temperature in the battery packs to prevent overheating and thermal runaway. The Energy Management System regulates the energy exchange with the grid. Power electronics (inverters) convert DC into AC before power is injected into the grid. In some cases (high-voltage grids), a transformer might be required to feed electricity into the grid.

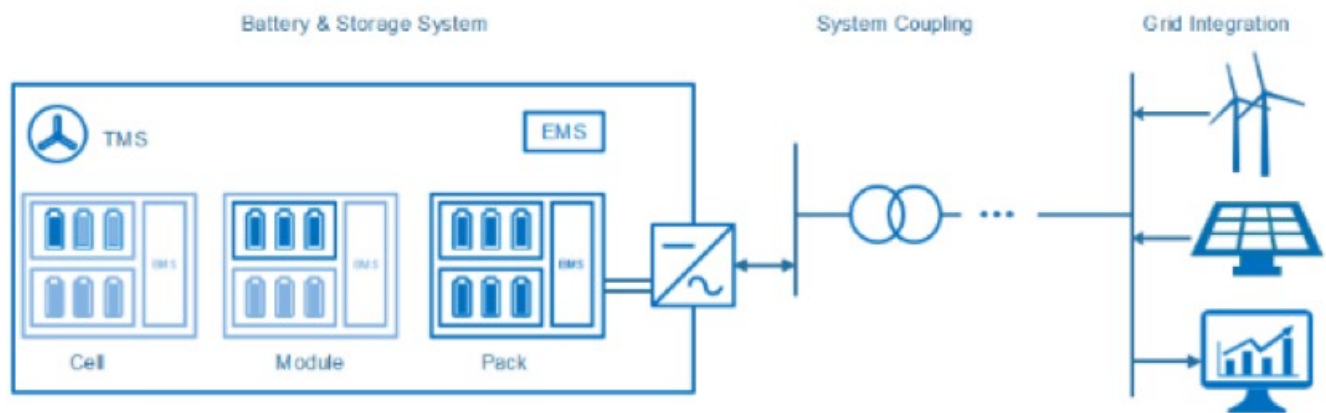

Figure 20: Schematic illustration of a grid-scale battery storage system

Charging and discharging rates of LIB are often measured with the C-rate, which is the maximum capacity the battery can deliver relative to its energy volume. For example, if a battery can be fully discharged in 20 minutes, 1 hour or 2 hours then it has C-rates of 3C, C or C/2 respectively. Operations at higher C-rates than specified in the battery pack could be possible but would lead to a faster degradation of the cell materials [3]. LIB do not suffer from the memory effect issue (the effect of batteries gradually losing their maximum energy capacity if they

are repeatedly recharged after being only partially discharged) and can be used for variable depths of discharge at short cycles without losing capacity [4]. The relationship between battery volume (in MWh) and loading/unloading capacity (in MW) can be customized based on the system needs and to obtain a better business case.

The lifetime of battery energy technologies is measured by the total number of cycles undergone over the lifetime. Nowadays, a Li-Ion

battery typically endures around 10,000 full charge/discharge cycles.

Criteria evaluation for LIB utility scale

Criteria evaluation	5.a. Bat, Li-Ion Utility scale
Capacity in wintertime	WW
Implementation speed	QQ
Technology resilience	RR
Levelized cost of electricity	C
General score (1-3)	1,8

Table 22: LIB utility scale - criteria evaluation matrix

Winter impact (production at wintertime)

LIBs are suitable for electricity storage in all seasons of the year. In systems with variable renewable energy (VRE) sources, LIBs are an efficient technology for ensuring stability because they can deliver full power within seconds. However, the effectiveness of batteries diminishes in colder temperatures, particularly below 0°C. And batteries can have trouble starting charging or discharging in colder temperatures. Furthermore, LIBs are not suitable for storing over a longer time periods e.g. over more weeks, thereby, not suitable for seasonal shift of energy production because of a relatively high rate of self-discharging and the high cost of the storage part.

Implementing speed

The implementation speed of batteries in Ukraine is influenced by several factors, such as the delivery time, the technical installation time, the logistics, and the knowledge requirements. The delivery time of batteries is a minimum of six months. For very large systems (100 MW) the delivery time may extend up to 1-2 years. The logistics of transporting batteries to Ukraine can be challenging, as suppliers only delivers to Poland or Romania, and the buyer must plan the transportation from there to Ukraine. However, batteries are optimized

for transportation – they are heavy but optimized in containers.

The technical installation time of batteries in Ukraine is about 2-3 weeks, depending on the complexity of accessing the electrical system. The installations time also depends on the functions of the battery, e.g., if it needs to be able to restart the system in case of a blackout. The implementation of batteries in Ukraine requires an electrical engineer.

Altogether, this results in an implementation period of a minimum of 7 months for systems of approx. 20MW. Larger systems are expected to have a longer delivery time, increasing the implementation time.

Resilience

The use of battery systems is effective for ensuring stability in power supply. In situations where the electricity grid or electricity production is damaged, batteries can briefly function as a backup as they can deliver their full effect within a few seconds. However, in the context of war, batteries, like other energy infrastructure, face vulnerability. Unlike wind turbines, large scale batteries are easier targets since it is one unit of a relatively large size.

The compact nature of batteries does however also mean that they potentially can be camouflaged or protected by layers of concrete.

Generation costs (LCOE), short term and over the lifetime

Over a two-year span, considering an emergency scenario, the Levelized Cost of Electricity (LCOE) for batteries is projected to be 2025 EUR/MWh, presenting a comparatively higher figure than several technologies, but a lower cost than e.g., solar PVs

Examining the lifetime perspective, the LCOE of 264 EUR/MWh for batteries is regarded as notably high when contrasted with the array of alternatives explored in this technology catalogue.

While battery costs have fallen dramatically in recent years due to the scaling up of electric vehicle production, market disruptions and competition from electric vehicle makers have led to rising costs for key minerals used in battery production, notably lithium. It is now becoming evident that further cost reductions rely not just on technological innovation, but also on the prices of battery minerals.

Community batteries

Brief technology description

Battery energy storage systems can have manifold applications and thus can be installed at different scales and voltage levels (see Figure 19). BESS architecture is ultimately shared across use types, with minor differences depending on the single applications. In off-grid and micro-grid (e.g., community batteries) contexts, grid connection costs are reduced totally or partially.

A community battery is a shared solution for a local neighborhood that allows both that neighborhood and the wider community to access the multiple benefits batteries can provide.

Industry and households can install batteries behind the meter to reshape the own load curve and to integrate distributed generation such as rooftop or industrial PV. The major benefits are related to retail tariff savings, peak tariff reduction, reliability, and quality of supply [5]. Batteries can boost the self-consumption of electricity and back up the local grid by avoiding overload and by deferring new investments and reinforcements. In case of bi-directional flows to/from the grid (prosumers), BESS can increase the power quality of distributed generation and contribute to voltage stability. In developed market settings, these functions might not only reflect requirements enforced by the regulation, but also materialize in remunerated system services.

Criteria evaluation for community scale LIB

Criteria evaluation	5.b. Bat, Li-Ion community scale
Capacity in wintertime	WW
Implementation speed	QQQ
Technology resilience	RR
Levelized cost of electricity	CC
General score (1-3)	2,3

Table 23: LIB community scale- criteria evaluation for community scale LIB

Winter impact (production at wintertime)

Batteries are suitable for electricity storage in all seasons of the year. However, the effectiveness of batteries diminishes in colder temperatures, particularly below 0°C. And batteries can have trouble starting charging or discharging in colder temperatures. Furthermore, LiBs are not suitable for storing over a longer time periods e.g. over more weeks, thereby, not suitable for seasonal shift of energy production because of a relatively high rate of self-discharging and the high cost of the storage part.

Implementing speed

Community batteries and other smaller battery systems exhibit greater agility compared to the larger batteries. One notable advantage of community batteries lies in their shorter delivery times compared to larger-scale batteries. The modular design and smaller scale contribute to a more streamlined manufacturing process, allowing for quicker production and dispatch.

Resilience

The use of battery systems is effective for ensuring stability in power supply. In situations where the electricity grid or electricity production is damaged, batteries can briefly function as a backup as they can deliver their full effect within a few seconds. In the context of war, batteries, like other energy infrastructure, face vulnerability. Unlike wind turbines, batteries are easier targets since it is one unit of a relatively large size.

The compact nature of batteries does however also mean that they potentially can be camouflaged or protected by layers of concrete.

Generation costs (LCOE), short term and over the lifetime

Over a two-year span, considering an emergency scenario, the cost of community batteries is

estimated to be 1899 EUR/MWh. This is higher than many other technologies but a slightly lower price than for grid-scale batteries. Looking at the overall lifetime, the cost of community batteries is 437 EUR/MWh. This is considered high compared to the other options we've explored in this technology catalog.

Parameter evaluation for batteries

Parameters	5.a. Bat, Li-Ion Utility scale	5.b. Bat, Li-Ion community scale
P1-Electricity production at wintertime	50%	50%
P2-Levelized Cost of Electricity (LCOE) short lifetime, winter production [€/MWh]	2025	1899
P3-Levelized Cost of Electricity (LCOE) over lifetime [€/MWh]	264	439
P4-Distributed generation	5-150 MW	40-200 kW
P5-Regulation requirement in the project development process	In between	In between
P6-Delivery time and availability of components and materials	In between	In between
P7-Requirements for logistics and transportation infrastructure	Low	Low
P8-Technical installation time (after clearance)	Quick and easy	Quick and easy
P9-Requirements for skilled staff in construction phase	Low	Low
P10-Grid balancing capacity	High	High
P11-Requirements for electricity grid infrastructure	Easy	Easy
P12-Requirements for skilled staff for operation and maintenance and for special spare parts	Low	Low
P13-Possibility for camouflage and sheltering	Medium potential	Medium potential
P14-Risk associated with fuel supply	Medium risk	Medium risk

Table 24:Parameters evaluation matrix for batteries. The LCOE unit is [€/MWh].

P1: Electricity Production at Wintertime (W)

Batteries, while versatile for electricity storage throughout the year, experience diminished effectiveness in colder temperatures, particularly below 0°C, impacting their winter production capabilities. And batteries can have trouble starting charging or discharging in colder temperatures. Furthermore, LiBs are not suitable for storing over longer time periods e.g. weeks, thereby, not suitable for seasonal shift

of energy production because of a relatively high rate of self-discharging and the high cost of the storage part.

P2: Levelized Cost of Electricity (LCOE) Short Lifetime (C)

Lithium-ion batteries are relatively expensive technologies compared to some production technologies assessed in this technology catalog, such as solar PVs. The cost of batteries has been on a decreasing trend over the past

years due to significant investments in developing efficient batteries for electric vehicles.

P3: Levelized Cost of Electricity (LCOE) Over Lifetime (C)

Over the lifetime, the cost for batteries is comparatively high cost when compared to alternative technologies explored in this technology catalog.

P4: Distributed Generation (R)

Batteries contribute to distributed generation, offering localized power storage and distribution capabilities.

P5: Regulation Requirement in the Project Development Process (Q)

The regulatory aspects in the development process for battery projects need to consider optimal integration within the energy landscape. For the time being UA are missing legislation on connecting of batteries at system level.

P6: Delivery Time/Availability of Components and Materials (Q)

Delivery times for grid-scale batteries range from a minimum of six months to 1-2 years for very large systems, impacting implementation speed. Community batteries generally have shorter delivery times.

P7: Requirements for Logistics and Transportation Infrastructure (Q)

The containerized design of batteries facilitates transportation to Ukraine using trucks, streamlining logistics.

P8: Technical Installation Time (Min Time After Clearance) (Q)

The technical installation time for batteries in Ukraine is approximately 2-3 weeks, contingent on factors like access to the electrical system and specific functionalities.

P9: Requirements for Skilled Staff in Construction Phase (Q)

Implementing batteries during the construction phase in Ukraine necessitates skilled staff, particularly electrical engineers.

P10: Grid Balancing Capacity (/Demands) (R)

Batteries contribute to grid balancing capacity and demands, enhancing stability in power supply.

P11: Requirements for Electricity Grid Infrastructure (R)

The use of batteries requires careful consideration of electricity grid infrastructure requirements to ensure compatibility and optimal performance.

P12: Requirements for Skilled Staff for Operation and Maintenance and for Special Spare Parts (R)

The operation and maintenance of batteries in Ukraine demand skilled staff, impacting long-term resilience. Additionally, the need for special spare parts adds complexity to the maintenance process.

P13: Possibility for Camouflage and Sheltering (R)

Batteries can potentially be camouflaged or sheltered. Community batteries, being smaller, may be considered less likely targets for potential threats.

P14: Risk Associated with Fuel Supply (R)

Unlike some other energy sources, batteries are not subject to risks associated with fuel supply, contributing to their reliability.

Data sheet
In Appendix F



Biogas

BIOGAS PLANT

Biogas plants have not been evaluated.

The biogas plant is only included as a technology which produce fuel to the gas engine, fueled by biogas, solely supplied by a green-field project biogas plant. In this section only a brief technology description of the biogas plant is included. The evaluation of the biogas power produced by the gas engine is made in the section.

Brief technology description

Biogas produced by anaerobic digestion is a mixture of several gases. The most important part of the biogas is methane but also CO₂ will make up a considerable part. Biogas has a caloric value between 23.3 – 35.9 MJ/m³, depending on the methane content. The percentage of volume of methane in biogas varies between 50 to 72% depending on the type of substrate and its digestible substances, such as carbohydrates, fats and proteins. If the material consists of mainly carbohydrates, the methane production is low. However, if the fat content is high, the methane production is likewise high. For the operation of power generation or CHP units with biogas, a minimum concentration of methane of 40 to 45% is needed. The second main component

of biogas is carbon dioxide. Its share in biogas reaches between 25 and 50% of volume. Other gases present in biogas are hydrogen sulphide, nitrogen, hydrogen, steam, and carbon monoxide [6], [7]

Anaerobic digestion (AD) is a complex microbiological process in the absence of oxygen used to convert the organic matter of a substrate into biogas. The population of bacteria which can produce methane cannot survive with the presence of oxygen. The microbiological process of AD is very sensitive to changes in environmental conditions, like temperature, acidity, level of nutrients, etc. The temperature range that would give better cost-efficiency for operation of biogas power plants are around 35 – 38°C (mesophilic) or 55 – 58°C (thermophilic). Mesophilic gives hydraulic retention time (HRT) between 25 – 35 days and thermophilic 15 – 25 days [6]

Examples of expected feedstocks of biogas production in Ukraine are manure, Jatropha, Castor, Croton, and related seeds. Biogas production units could also be used for treatment of municipal solid waste. Some of the biomass potential can be converted to biogas.

Biogas from a biodigester is transported to the gas cleaning system to remove sulphur and moisture before entering the gas engine to produce electricity. The excess heat from power generation with internal combustion engines can be used for space heating, water heating, process steam covering industrial

steam loads, product drying, or for nearly any other thermal energy need. The efficiency of a biogas power plant is about 35% if it is just used for electricity production. The efficiency can go up to 80% if the plant is operated as combined heat and power (CHP).

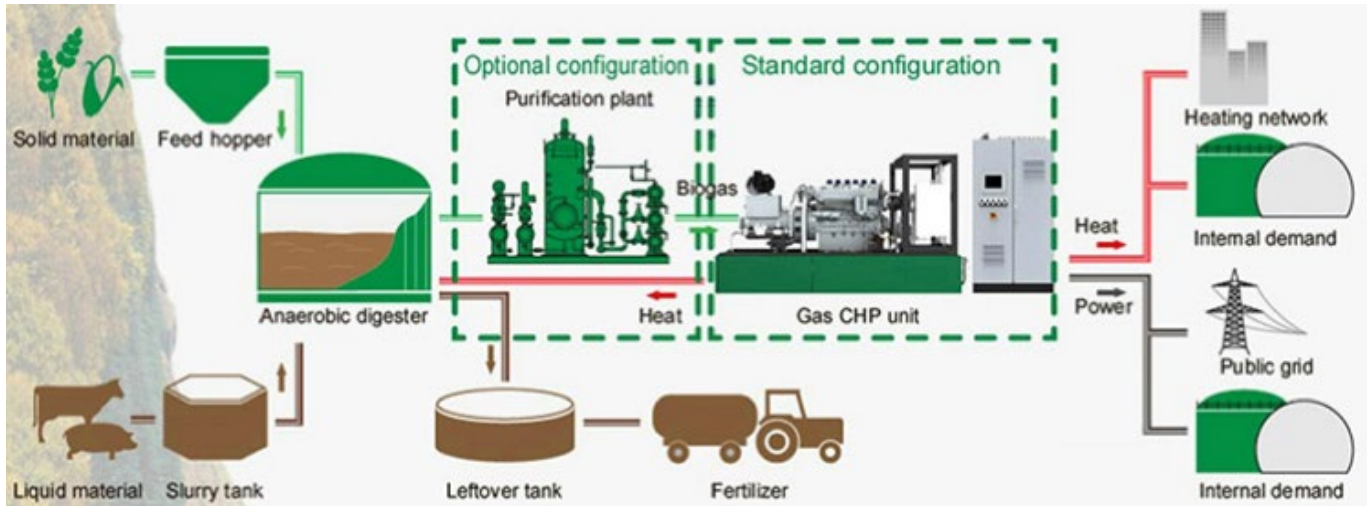

Figure 21: Schematic diagram for a biogas CHP system [8]

Coal Power Plants, Repair and Lifetime Extension

Capacity
in wintertime



Implementation
speed



Technology
resilience



Levelised cost
of electricity



General score:



COAL POWER PLANTS, REPAIR AND LIFE-TIME EXTENSION (REPLACEMENT OF EQUIPMENT)

The rating on the frontpage shows the score for the technology achieving the highest general score among the sub technologies evaluated in the chapter. The more icons the better

performance¹⁶. The two sub- technology measures achieve the same score. The scores for all sub-technologies are shown in Table 25.

Criteria evaluation	4. Coal retrofit- ting	4. Coal repair
Capacity in wintertime	WWW	WWW
Implementation speed	QQ	QQ
Technology resilience	R	R
Levelized cost of electricity	CCC	CCC
General score (1-3)	2.3	2.3

Table 25: Coal power - overall criteria evaluation matrix

This chapter covers the possibility of extending the lifetime of coal-based power plants, as well as giving some insights to the proportion of the cost for each component category which a coal-based power plant consists of.

generation capacity of 18.59 GW from coal-based power plants, in 2021. In that year the power generation from coal-based power plants was 43,51 TWh, making up 29% of Ukraine's total power generation.

Based on data from the ENTSO-E Transparency platform, the Ukrainian power system had a

The proportion of the cost is reported, because as of 2021 a large part of the power generation

¹⁶ See detailed explanation in Table 2: Overview of which parameters contribute to which criteria and visualizing of the ratings, the more icons the better rating.

capacity in Ukraine, consisted of coal-fired power plants and some of the coal-based power plants might not need a full lifetime extension, but a replacement of a single component category. Replacements of the components are necessary, as the Ukrainian energy infrastructure is under constant attack from Russia, which means that some of the coal-fired power plants either are or will be completely or partially destroyed.

Brief technology description

A coal-fired power plant works by taking delivery of shipments of coal, through railway, barges, and/or ships, where it is stored in a coal yard. Thereafter, the coal is typically ground to powder for efficient burning and blown into the combustion chamber of a boiler, where water is heated to extremely high temperatures turning the water into highly pressurized steam. In some coal plants, the coal is fed directly into the combustion chamber, without being ground. The steam is led through a turbine, which drives the driveshaft connected to the generator, that produces electricity with each revolution of the magnet within the generator. The steam is led to a condenser, with a heat exchanger, that transfers the steam back into hot water which is led into the boiler again. This is done, so that there is no need for a huge temperature change in the water, for it to become steam. The heat exchanger transfers the heat energy to the water in a district heating grid or to cold water sourced from the area, which is led out to the local environment again. As the water passes through a heat exchanger, it does not absorb any of the pollutants of the combustion process, only the heat energy.

When a coal power plant has been in operation for a long time (e.g., 25 years or more), the reliability of its components and systems will likely decrease leading to reduced availability and/or increased O&M costs. Therefore, based on experience, it will usually be necessary and beneficial to carry out a larger package of work that addresses repairs, renovation, and replacement of selected components and systems depending on their actual condition. Often also, improvement of environmental performance may be required, e.g., by improving the flue gas cleaning performance. This 'Life Time Extension' (LTE) is done with the purpose of restoring the plant to come close to its original conditions in terms of availability, efficiency and O&M costs. The exact scope and extent of such a campaign though, shall be tailored to the actual plant in question and will depend on its design, previous records of operation, earlier major works carried out, etc. Also, the expected/desired future operation of the plant is considered. Whether or not to extend the life of a power plant is therefore not a simple decision but involves complex economic and technical factors.

It may be convenient to carry out all necessary work in one campaign, to reduce the overall down time. For this case it is assumed that all work is done in one campaign. It is expected that the original plant complies with the environmental legislation at the time of the LTE. The costs of bringing it up to date prior to the LTE are therefore not considered. The LTE described here does not take specific measures to increase the efficiency, emissions level standards, or regulation abilities of the plan

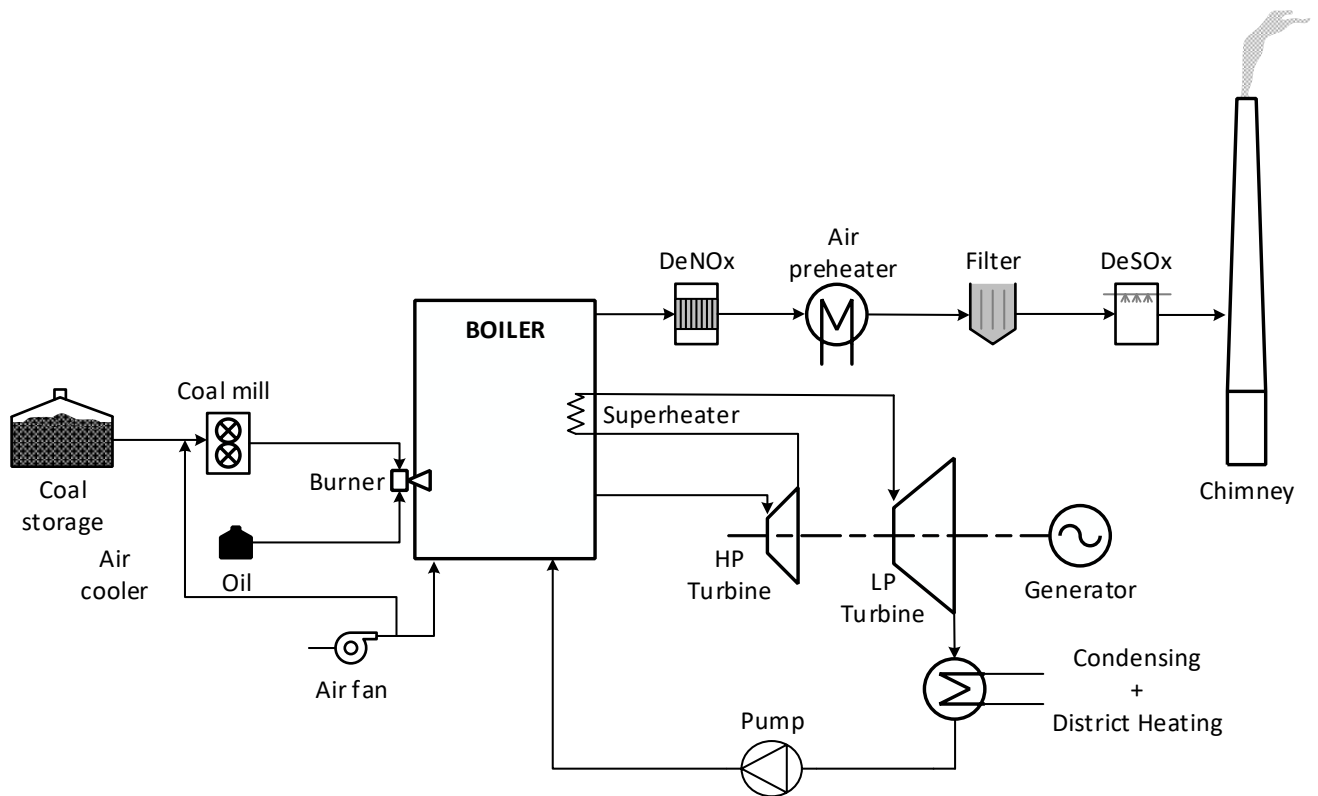

Figure 22: Sketch of the main elements of a large coal fired CHP plant

In connection with the LTE the plant will be out of operation for a period, typically 6-9 months. The cost of the LTE will depend on the scope of the campaign and specific component categories that are to be replaced. These are given as follows:

- Revision of electrical systems
- Instrumentation and control systems replacement
- Pulverizes upgrade or replacement (fuel supply and disposal)
- Boiler upgrade
- Turbine refurbishment (possibly generator refurbishment)
- Water systems (heat exchanges for condensers and district heating)
- Buildings
- Flue gas cleaning

To decide which component categories that needs to be refurbished and included in the LTE, the plant's condition needs to be investigated to obtain an understanding of its condition. This can be done by using diagnostic

systems and making a detailed remaining life assessment. The proportion of the investment cost for the lifetime extension of a coal-fired power plant is given in Figure 23.

Share of a coal-fired power plants component cost - LTE

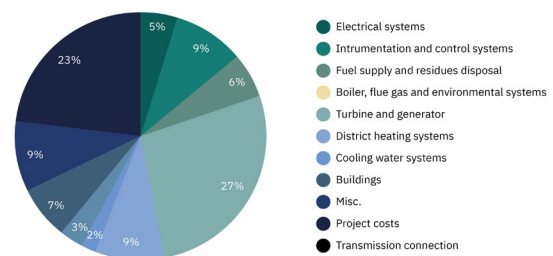

Figure 23: Illustrates the proportion of the investment cost, when a coal-fired power plant's lifetime is extended. [13]

Sometimes whole parts of the plant need to be replaced, and in the case of Ukraine, the parts of the plant i.e. the component categories might

have been destroyed by Russian bombardments. The expenditure for the repairs is different from the lifetime extension of the plant, as the components probably need to be fully replaced. The price for the component categories are therefore considered to be similar to the investment cost of a new coal-fired power

plant. Figure 24 presents the proportions of investment costs for different component categories within a new coal-fired power plant. This can be used as an indicator for what the expected price of a component category might be, when a coal-fired power plant is repaired.

Share of a coal-fired power plants component cost - New coal-fired power plant

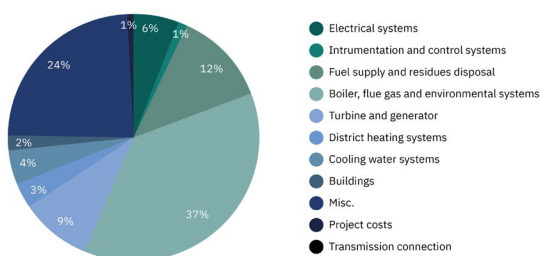

Figure 24: Illustrates the proportion of the investment cost, when a coal-fired power plant’s component category is replaced with new components. The proportion should be multiplied by the cost of a new coal-fired power plant.

Criteria evaluation coal plants Coal Power Plants, Lifetime Extension

Criteria evaluation	4. Coal retrofiting	4. Coal repair
Capacity in wintertime	WWW	WWW
Implementation speed	QQ	QQ
Technology resilience	R	R
Levelized cost of electricity	CCC	CCC
General score (1-3)	2.3	2.3

Table 26 Coal Power Plants, Lifetime Extension – criteria evaluation matrix

Winter impact, production at wintertime (W)

Lifetime extension or repairs of existing Ukrainian Coal-fired Power Plants can significantly contribute to the Ukrainian power system in the winter.

Lifetime extension can have a significant impact, because the refurbishment of the coal-fired power plants, can lead to increased

output capacities, as the older power plants may have lower production levels than their design parameters and the refurbishment then raises the plant’s production to their normal levels. Furthermore, during the lifetime extension, newer technologies can be implemented, which can further increase output levels.

Repairs of a coal-fired power plant can have a significant impact, as a power plant is quickly

reintroduced to the electricity system.

Coal-fired power plants can regulate their generation allowing them to produce at full capacity during wintertime.

Implementing speed (Q)

Even though many of the coal-fired power plants are readily available to receive a lifetime extension or repairs and the refurbishment typically takes 6-9 months, the implementation of the lifetime extension is still expected to take around 1.5 years. This is because on top of the implementation, the components for the plants need to be sourced, there is a planning and training process for the refurbishment of the coal-fired plants.

Resilience (R)

The lack of resilience of the lifetime extension of coal-fired power plants is attributed to the high capacity of a single power plant. The capacity of the coal-fired power units in Ukraine ranges between 150-325 MW and plants range up to 2300 MW, which means that a large portion of the power generation can be taken out, through a single strike on a power plant. Which can happen right after its refurbishment, either through drone, artillery or missile strike. Furthermore, due to the size of a coal-fired power plant, it cannot be expected that the whole plant can be bunkered, although some critical parts can be.

The majority of Ukrainian coal, which was used to fire the coal plants, originated from Ukrainian coal mines in the Donbass region. At the present time, this region is either occupied by Russian forces or an active warzone, which means that the coal mines are inaccessible for mining. Therefore the coal for the power plants, needs to be sourced from the

international market. The availability of coal has significantly dropped for the Ukrainians, meaning that coal as a fuel is less reliable.

Generation costs (LCOE), short term and over the lifetime (C)

Due to the lifetime extension of coal fired power plant's, low upfront cost and great potential for generation during the winter, using life time extension as a solution demonstrate to have the lowest generation cost among all the technologies over two winters. In the case of the LCOE over the lifetime, the LTE of a coal-fired power plant is expected to be around medium in comparison to all the other assessed technologies, which means the price is approximately two times higher than onshore windturbines.

There can be many different forms of repairs needed for a coal-fired power plant, which has been struck via dronestrike, missiles or artillery. Some coal-fired power plants might need to be fully repaired while others only need small repairs. Therefore the proportions of the investment cost needed for replacing a component category has been given on Figure 24. In the assesment of the LCOE for a coal-fired power plant which needs to be repaired, it is assumed that the cost for repairing a coal-fired power plant is 30% of the cost for a new coal-fired power plant. In this case the LCOE over two winters is still expected to be the second best, right after the LTE of a coal-fired power plant. The LCOE of a repaired (30%) coal-fired power plant over the whole lifetime, is expected lie in the medium range, in comparison to the LCOE of the other technologies.

Parameter evaluation coal plants

This section covers the parameter evaluation of coal-fired power plants, which was used as the basis for the criteria evaluation.

Parameters	4. Coal retrofitting	4. Coal repair
P1-Electricity production at wintertime	>75%	>75%
P2-Levelized Cost of Electricity (LCOE) short lifetime, winter production [€/MWh]	160	149
P3-Levelized Cost of Electricity (LCOE) over lifetime [€/MWh]	119	117
P4-Distributed generation	500 MW	500 MW
P5-Regulation requirement in the project development process	In between	In between
P6-Delivery time and availability of components and materials	In between	In between
P7-Requirements for logistics and transportation infrastructure	Medium	Medium
P8-Technical installation time (after clearance)	Medium-term	Medium-term
P9-Requirements for skilled staff in construction phase	Medium	Medium
P10-Grid balancing capacity	Medium	Medium
P11-Requirements for electricity grid infrastructure	Moderate	Moderate
P12-Requirements for skilled staff for operation and maintenance and for special spare parts	Low	Low
P13-Possibility for camouflage and sheltering	Low potential	Low potential
P14-Risk associated with fuel supply	Medium risk	Medium risk

Table 27 Coal Power Plants, Lifetime Extension – parameters evaluation matrix. The LCOE unit is [€/MWh].

P1: Electricity production at wintertime (W)

If there is fuel available, coal fired power plants may operate at their full capacity any hour of the day, except for the planned and forced outages. Depending on the specific power plants there are different requirements for when the plant should be refurbished, meaning that there will be some weeks of the year where it is planned that the coal plants will be out of operation. Typically, the refurbishment is planned to be done during the summer, when the need for the plant is greatly lower. Forced outages can happen for multiple reasons, but typically occur due to some form of breakdown, which occurs during production.

As mentioned, the need for a coal-fired power plant is lower during the summer. The power consumption is lower. Furthermore, coal-fired power plants also compete amongst each other and against VREs and other power plants.

Due to these reasons, it is assumed that a coal-fired power plant will operate, to what equates as, full capacity for 5.000 hours during a year, so-called Full Load Hours (FLH). As the majority of the production is likely to happen during the winter period, it is assumed that 75% of the FLH will occur during the wintertime, which means that it is assumed that a coal-fired power plant, will operate with 3.750 full load hours during wintertime (86% capacity factor). This corresponds to the annual FLH of a wind turbine, located in the Ukrainian region with the best wind profiles and above twice the annual FLH of a PV plant located in the Ukrainian region with the best solar profile. If Ukrainian power plants do not cannibalize on each other, due to missing capacity caused by Russian bombardments, then the FLH can be expected to be higher. Furthermore, coal-fired power plants are expected to generate power in the intermediate and base load hours, which means that the FLH for coal-fired power plants can be expected to be higher than gas engines and turbines.

P2: Levelized Cost of Electricity (LCOE) short lifetime, winter production (C)

In the emergency scenario, where the lifetime extension of the coal-fired power plant is only utilized for two winter periods, the LCOE is the lowest of all the assessed technologies. The LCOE is calculated to be 160 €/MWh. For the explorative scenario, where the price for repairs is expected to be 30% of the initial plant investment cost, the LCOE is calculated to be 149 €/MWh – note that the LCOE of the repaired coal-fired power plant is indicative, there are many scenarios regarding the repairs of a bombarded coal-fired power plant.

The lifetime extension and repair of a coal-fired power plant stands out because the majority of the life-time expenditure is caused by the CO₂ emissions and fuel consumption, whereas the investment cost is relatively low, and so is the cost for operation and maintenance. As less fuel is consumed and the emissions are lower, as the operational period is significantly shorter, the fuel and emissions costs are proportionately lower in comparison to the investment cost, regarding the LCOE.

P3: Levelized Cost of Electricity (LCOE) over lifetime (C)

The LCOE over the lifetime extension period of a coal-fired power plant is expected to be approximately 120 €/MWh. This is 1.5 – 2.5 times higher than utility scale solar and wind power, but less than new gas engines and turbines. The emissions costs make up the vast majority of costs and therefore obviously, the generation cost from lifetime extended coal-fired power plants, are highly sensitive to cost of CO₂. The projected LCOE assumes a long-term CO₂ cost of 63 €/MWh. Secondly comes the fuel price, which is 29 €/MWh.

P4: Distributed generation (R)

Typically, the power generation capacity of a coal-fired power units in Ukraine ranges

between 150-325 MW and plants ranges up to 2300 MW, which means the generation capacity is very centralized.

P5: Regulation requirement in the project development process (Q)

The regulation requirement for lifetime extension of coal-fired power plants, is expected to be swift and easy, as the plant can be assumed to already hold a license to operate. But the planning process for what to refurbish the plant expects to take time. It is estimated that the planning process will be around 26 weeks, which is rated to be a medium time frame.

P6: Delivery time / availability of components and materials (Q)

The delivery time of all components and materials, for the refurbishment of a coal-fired power plant, is expected to be approximately 26 weeks from the initial purchase date. This is because there is an ongoing supply chain shortage for electrical components, where some of the components take between 26-52 weeks to be delivered, but it is expected that during the refurbishment or repairs, only some components are expected to be newly produced, and this varies between each coal plant. So, in general it is expected to take 26 weeks to source the components for the different coal plants. This is a medium time frame for sourcing components.

If a coal-fired power plant needs to be repaired, due to it being bombarded, the delivery time can vary significantly for the different components which are needed for the repairs. Through the interviews conducted with producers, it was hard to get a clear estimate for when they could deliver specific parts, but the estimates for when they could deliver the entire technological solution was clearer.

If no transformers are available and the transformer for a specific coal-fired power plant has been destroyed, it will take approximately

1 year before a new transformer can be obtained.

P7: Requirements for logistics and transportation infrastructure (Q)

This unit and the components needed for the construction, as well as the fuel, typically requires transport by equipment of the size of a train or a boat, which requires that the coal-fired power plant is located beside a harbor or railway. But as the coal plants are already built and only need to be refurbished or repaired, it is assumed that the coal plants are already located beside a railway or harbor. This means that the refurbishment or repair of a coal-fired power plant has a medium requirement for logistics and transportation infrastructure, as railways or harbors are already available, but they are still reliant on the transportation infrastructure. But there is probably no need for building new harbors or railways.

P8: Technical installation time (min time after clearance) (Q)

When the refurbishment of a coal-fired power plant is initialized, the refurbishment typically takes 26-39 weeks. Considering that the work need be undertaken while the plant is in risk of air attacks from Russia, special precautions may have to be taken and hence the upper level of the interval, i.e. 39 weeks, is considered a realistic time frame for refurbishment. If a coal plant has been struck by Russia, the time to repair the power plant depends heavily on how much has been destroyed. Some repairs will be faster than 26 weeks, but if the majority of the plant is destroyed, the amount of time required for repair works may resemble the construction time for a new plant. 39 weeks is considered to be a medium time frame.

P9: Requirements for skilled staff in construction phase (Q)

During the construction phase, general

laborers, heavy equipment operators, concrete workers, welders, plumbers, electricians, HVAC technicians and safety specialist workers are required. These laborer types should be available in Ukraine or can be sent from other countries, depending on company policies. If companies cannot send their employees to Ukraine to perform the construction due to security concerns, it is reasonable to assume that some companies can and will educate general laborers from Ukraine. As each coal-fired power plant is different from another and they are not based on modular builds, engineers are needed in some parts of the construction phase to oversee quality control. Furthermore, engineers are needed to adjust building schematics if something in the construction does not work as expected or properly. These are common issues for plants that are tailor made, in comparison to modular build solutions that are well tested. This is why the requirement for skilled staff is considered to be medium during the construction phase.

According to estimates provided by the Ukrainian partners, Ukraine is short of up to 5 million workers. Which means that during the construction phase, it might be hard to source the number of laborers needed for a large construction project.

P10: Grid balancing capacity (/demands) (R)

Assuming coal is available, a lifetime extended or repaired coal-fired power plant can produce electricity at any hour of the day. It takes several hours to conduct a cold startup, as components need to be heated gradually to avoid thermal stress and damage as a result. If the plant has not completely cooled down, it can conduct a warm startup which takes less time than a cold startup. If the plant has been briefly shut down, it can conduct a hot startup, which takes around 1 hour. In comparison to gas-fired power plants, coal-fired power plants are slower in ramping up their production.

Coal-fired power plants are often used for baseload or intermediate loads. By operating below their nominal capacity, coal-fired power plants may provide upregulating power in case another power plant suddenly shuts down. If some coal plants have been deliberately turned off, while others are running at full capacity, the up-regulation capacity is significantly reduced, as the coal-plants must conduct a cold startup in the case of a power plant outage, instead multiple coal-fired power plants ramping up.

Since coal-fired power plants are large units of several hundred MW, the failure of a power plant may bring the power system out of balance if the access to fast-regulating reserve units or flexible consumers present is insufficient.

Taking the considerations above into account, coal-fired power plants are expected to deliver a medium level of grid balancing capability.

P11: Requirements for electricity grid infrastructure (R)

As coal-fired power plants have a high electricity generation capacity, with a high minimum load, the requirement for the electricity grid infrastructure is quite high. The coal-fired power plants need to be connected to the transmission grid through a transformer.

As the LTE or repair of coal-fired power plants are conducted on existing facilities, it can be assumed that the plants are already integrated into the power grid, and placed in areas where the power is easily dispatched. So, unless the electricity grid infrastructure has been destroyed, there will be no need for further improvements to the power grid.

P12: Requirements for skilled staff for operation and maintenance and for special spare parts (R)

To keep a coal-fired power plant in operation,

operations-, maintenance-, instrumentation-, electrical- and mechanical technicians are required. Depending on the plant size, some of these technicians might not be needed for full-time employment but can be called in when there is a specific problem regarding their field of work. Operations technicians are needed for full-time employment, so they can operate the plant from its control room. The requirement for skilled labor is considered to be low, in comparison to other technologies.

P13: Possibility for camouflage and sheltering (R)

There is no possibility for camouflaging existing refurbishable or repairable coal-fired power plants, as they are large and immovable. Moreover, their location can be assumed to be well known by Russian intelligence.

Large parts of the coal-fired power plants cannot be sheltered, but some critical components, such as the transformer, may be reinforced or covered with steel plating, to minimize the damage from a direct strike on the plant. The transformer is relatively small and therefore can be sheltered, furthermore it is a critical component that would take up to a year for a supplier to deliver as brand new.

All in all, the possibility of camouflage and sheltering is considered to be low.

P14: Risk associated with fuel supply (R)

The majority of Ukrainian coal, which was used to fire the coal plants, originated from Ukrainian coal mines in the Donbass region. At the present time, this region is either occupied by Russian forces or an active warzone, which means the coal mines are inaccessible for mining. This means that coal for the power plants, needs to be sourced from the international market. Which means that the availability of coal has significantly dropped for the Ukrainians, meaning that coal as a fuel is less reliable than before the war.

Although, through freight trains running through Europe, coal can be purchased on the international markets and transported to the Ukrainian powerplants. Therefore, the risk associated with coal as a fuel supply is expected to be in the medium range.

Biomass Cogeneration Technologies

Capacity
in wintertime



Implementation
speed



Technology
resilience



Levelized cost
of electricity



General Score:



BIOMASS COGENERATION TECHNOLOGIES

The rating on the frontpage shows the score for the technology achieving the highest general score among the sub technologies evaluated in the chapter. The more icons the better

performance¹⁷. For the biomass CHP, it is the Wood pellets CHP(back pressure) medium that achieve the best score. The scores for all sub-technologies are shown in the table below.

Criteria evaluation	7.a. Wood pellets, CHP medium	7.b. Wood pellets, CHP Small	7c Wood Chips, CHP Medium	7d Wood Chips, CHP Small	7e Straw, CHP Medium	7f Straw, CHP Small
Capacity in wintertime	WWW	WWW	WWW	WWW	WWW	WWW
Implementation speed	QQ	QQ	Q	QQ	Q	QQ
Technology resilience	RR	RR	RR	RR	RR	RR
Levelized cost of electricity	CCC	C	CCC	C	CCC	C
General score (1-3)	2.5	2.0	2.3	2.0	2.3	2.0

This chapter covers the possibility of constructing new biomass-fired combined heat and power plants (CHP), to supply Ukraine with electricity and heat. These types of biomass-fired CHPs are:

- CHP, back pressure, fueled by wood pellets.
- CHP, organic Rankine cycle, fueled by

wood pellets.

- CHP, back pressure, fueled by wood chips.
- CHP, organic Rankine cycle, fueled by wood chips.
- CHP, back pressure, fueled by straw/stalks/husk.
- CHP, organic Rankine cycle, fueled by straw/stalks/husk.

¹⁷ See detailed explanation in Table 2: Overview of which parameters contribute to which criteria and visualizing of the ratings, the more icons the better rating.

Back pressure technologies can be manufactured across a broad spectrum of sizes, ranging from around tenths of megawatts to hundreds of megawatts. Organic Rankine cycle technologies range from a few kilowatts to multiple megawatts. In this project, the focus is on back pressure CHPs with around 25MW capacity and organic Rankine cycle CHPs with capacities around 3MW.

Brief technology description – Back pressure

This chapter focuses on solid biomass for combustion destined to combined heat and power generation (CHP). Wood chips, wood pellets and straw/stalks are considered for the biomass plants. Other types of biomasses e.g. other forest industry residues; sawdust and nut shells may be relevant as energy source, while different fuels set different technical requirements for the plant, these differences will not be addressed.

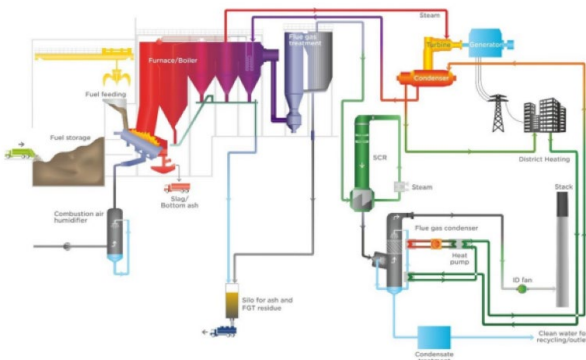

Figure 25: Main systems of a CHP facility, example waste to energy CHP facility [Technology Data - Energy Plants for Electricity and District heating generation, 2016, Danish Energy Agency]

The main systems are presented in Figure 25. The core components of a biomass fired backpressure CHP plant are: - Fuel reception and storage area, - Furnace or firing system including fuel feeding - Steam boiler - Steam turbine and generator, - Flue gas treatment (FGT) system potentially including an SCR-system for NOx reduction - Systems for handling of combustion and flue gas treatment residues

- Optional flue gas condensation system -
Optional combustion air humidification system.

The energy contained in the biomass is extracted through the combustion of the fuel, inside a combustion chamber. Water is led through a medium in the combustion chamber, heating it to extremely high temperatures, transforming the water to highly pressurized steam. The steam is led through a turbine connected to a generator, to produce electricity. The steam is then condensed back to water through a heat exchanger, which uses the waste heat in a district heating grid. CHP production from biomass has been used in an increasing scale for many years utilizing different technologies. The turbine is either a backpressure – or an extraction turbine. In the backpressure turbine, the expansion ends in the district heat condensers, in the extraction unit the expansion is extended to the lowest possible pressure, which is provided by a water-cooled condenser. Extraction units may run in backpressure or condensing mode as well as every combination in between.

Application of flue gas condensation for further energy recovery is customary at biomass fired boilers using feedstock with high moisture content, e.g., wood chip, except at small plants below 1 - 2 MWth input due to the additional costs. Plants without flue gas condensation are typically designed for biomass fuels with less than 30% moisture content. The flue gas condensation may raise the heating efficiency with 5-10%.

Brief technology description - Organic Rankine Cycle

An alternative type of CHP plant is the organic Rankine cycle plants (ORC plants), where the (biomass-) boiler is used for heating (no evaporation) thermal oil. This heated oil transfers the heat to an ORC plant which is similar to a steam cycle but uses a refrigerant instead of water as working medium.

To keep investments costs low, ORC plants are normally delivered in standardized complete modules in combination with 'a boiler' that only

is used for heating oil. The ORC technology is a waste heat recovery technology developed for low temperature and low-pressure power generation. The ORC unit is a factory assembled module making them less flexible but relatively cheap and thus more attractive particularly for small scale CHP facilities. The ‘Rankine’ part indicates that it is a technology with similarities to water-steam (Rankine) based systems.

The main difference being the use of a medium i.e., a refrigerant or silicone oil (an organic compound that can burn but does not explode) with thermodynamic properties that makes it more adequate than water for low temperature power generation.

Criteria evaluation - Biomass CHP medium scale back pressure

Criteria evaluation	7.a. Wood pellets, CHP medium	7c Wood Chips, CHP Medium	7e Straw, CHP Medium
Capacity in wintertime	WWW	WWW	WWW
Implementation speed	QQ	Q	Q
Technology resilience	RR	RR	RR
Levelized cost of electricity	CCC	CCC	CCC
General score (1-3)	2.5	2.3	2.3

Table 28 Criteria evaluation matrix for back pressure CHPs using wood pellets, -chips and straw as fuels.

Winter impact, production at wintertime (W)

Biomass back pressure Combined Heat and Power (CHP) plants have the potential to significantly contribute to the Ukrainian power system, particularly during winter. In addition to supplying power, these plants can provide heating to local urban areas. They have the ability to regulate their generation, enabling them to operate at full capacity in the colder months. However, it is important to note that unlike gas turbines or engines, biomass back pressure CHP plants are unable to rapidly scale their production.

Implementing speed (Q)

The timeline for the implementation of a biomass back pressure CHP plant hinges significantly on the project size. The planning process for such a plant is expected to be around half a year and the time of delivery after a biomass back pressure CHP plant has been ordered, is

expected to be one and a half years. Based on previous experience installation time is estimated to take around one year. Accounting for planning and regulatory approvals, the overall project delivery time and the installation time, the project can be expected to take 3 years, before it is completed.

Resilience (R)

The resilience of biomass back pressure Combined Heat and Power (CHP) plants hinges on two key factors. First, these plants, each with a capacity of around 25MW, can be strategically distributed across a wide geographic area. This allows them to collectively deliver a substantial production capacity while only moderately affecting the balance of the power grid if one plant is targeted by missiles, artillery, or drones. Second, despite the relatively large footprint of a 25MW biomass back pressure CHP plant, its design permits a significant portion of the power plant to be bunkered, enhancing its resilience.

Generation costs (LCOE), short term and over the lifetime (C)

Considering the Levelized Cost of Energy (LCOE), both short-term and over the lifetime, biomass back pressure CHP plants exhibit a competitive edge. When operational over two winters, these plants demonstrate a lower LCOE compared to several other evaluated technologies. However, it is worth noting that their LCOE falls on the higher end of the 'low' category, bordering the 'medium' price range. Over their lifetime, the LCOE for these plants, when using wood pellets and chips as fuel, is

categorized as 'medium'. When straw is used as fuel, the LCOE is classified as 'low'. For all biomass CHP technologies, the costs of electricity generation are dependent on the revenues from selling heat to district heating companies.

Parameter evaluation – Back pressure CHP plants

This section covers the parameter evaluation of biomass CHP medium scale back pressure, which was used as the basis for the criteria evaluation.

Parameters	7.a. Wood pellets, CHP medium	7c Wood Chips, CHP Medium	7e Strawhusk/ stalks, CHP Medium
P1-Electricity production at wintertime	>75%	>75%	>75%
P2-Levelized Cost of Electricity (LCOE) short lifetime, winter production [€/MWh]	1153	1351	1306
P3-Levelized Cost of Electricity (LCOE) over lifetime [€/MWh]	146	148	137
P4-Distributed generation	20-35 MW	20-35 MW	24-26 MW
P5-Regulation requirement in the project development process	In between	In between	In between
P6-Delivery time and availability of components and materials	Lengthy and complicated	Lengthy and complicated	Lengthy and complicated
P7-Requirements for logistics and transportation infrastructure	Medium	Medium	Medium
P8-Technical installation time (after clearance)	Lengthy and complicated	Lengthy and complicated	Lengthy and complicated
P9-Requirements for skilled staff in construction phase	Medium	Medium	Medium
P10-Grid balancing capacity	Medium	Medium	Medium
P11-Requirements for electricity grid infrastructure	Moderate	Moderate	Moderate
P12-Requirements for skilled staff for operation and maintenance and for special spare parts	Medium	Medium	Medium
P13-Possibility for camouflage and sheltering	Low potential	Low potential	Low potential
P14-Risk associated with fuel supply	Low risk	Low risk	Low risk

Table 29: Parameter evaluation matrix of biomass CHP medium scale back pressure plants. The LCOE unit is [€/MWh].

P1: Electricity production at wintertime (W)

If there is fuel available and a sufficient demand for district heating, biomass back pressure

CHP plants may operate at their full capacity any hour of the day, except for the planned and forced outages. Depending on the specific CHP plants there are different requirements for

when the plant should be refurbished, meaning that there will be some weeks of the year where it is planned that the biomass plants will be out of operation. Typically, the refurbishment is planned to be done during the summer, when the need for the plant is lower. Forced outages can happen for multiple reasons, but typically occur due to some form of breakdown taking place during production.

As mentioned, the need for biomass CHPs is lower during the summer. The power consumption is lower. Furthermore, there are a competition amongst each other and against VREs and other power plants.

During summer, electricity generation from biomass back pressure plants may be constrained by a low demand for heat. Extraction plants provide a higher degree of flexibility as they can run in condensing mode when the heat demand is insufficient.

Due to these reasons, it is assumed that a biomass CHP plant will operate, to what equates as, full capacity for 5.000 hours during a year, so-called Full Load Hours (FLH). As the majority of the production is likely to happen during the winter period, it is assumed that 75% of the FLH will occur during the wintertime, which means that it is assumed that a biomass CHP, will operate with 3.750 full load hours during wintertime (86% capacity factor). This corresponds to the annual FLH of a wind turbine, located in the Ukrainian region with the best wind profiles and above twice the annual FLH of a PV plant located in the Ukrainian region with the best solar profile. Furthermore, biomass back pressure CHP plants are expected to generate power in intermediate and base load hours, which means that the FLH for biomass back pressure CHP plants can be expected to be higher than gas engines and turbines.

P2: Levelized Cost of Electricity (LCOE) short lifetime, winter production (C)

In the emergency scenario, where the biomass back pressure CHP plants is only utilized for

two winter periods, the LCOE is the highest price in the lower category. The LCOE is calculated to be 1150 €/MWh for a wood pellet plant, 1350 €/MWh for a wood chip plant and 1300 €/MWh for a straw-fired plant.

The majority of these costs are tied to the CapEx and finance costs, as the plants will not be able to deliver power for their full lifetime expectancy.

P3: Levelized Cost of Electricity (LCOE) over lifetime (C)

The LCOE over the wood pellet back pressure CHP plants lifetime is expected to be approximately 146 €/MWh. The LCOE for the wood chip back pressure CHP is calculated to be 148 €/MWh and for the straw-fired back pressure CHP it is calculated to be 137 €/MWh. For the wood pellet and wood chip CHP plant, this LCOE is considered to lie in the medium price range, but the straw-fired CHP lies in the lower price range. These prices are 2.5 – 3.5 times higher than onshore wind power and 1.5 – 2.5 times higher than utility scale photovoltaics, but equivalent to new gas engines and turbines.

The generation costs of biomass back pressure CHP plants are approximately equally distributed among operational expenses (OpEx), fuel costs, and capital expenditures (CapEx).

P4: Distributed generation (R)

Biomass back pressure Combined Heat and Power (CHP) plants are projected to have a power generation capacity of approximately 25 MW. This capacity is somewhat centralized when compared to wind turbines and gas engines but decentralized in comparison to coal-fired power plants or nuclear power plants. As a result, the distribution capability of these medium-sized biomass back pressure CHP plants is considered to be moderate.

In light of the current situation in Ukraine, there are several arguments in favor of distributed installations. These installations, strategically

located near demand centers, have the advantage of reducing reliance on the transmission grid. This mitigates the risks associated with potential losses in power production capacity. Furthermore, generating power locally at the end-user's site reduces the need for extensive electricity transmission, thereby enhancing energy security.

P5: Regulation requirement in the project development process (Q)

With a capacity of around 25 MW, biomass back pressure CHP plants are not anticipated to significantly impact the local environment. This suggests that the environmental approval process could be more straightforward compared to larger facilities. Their relatively modest capacity also implies that the grid connection approval process might be less complex than for larger power plants.

Despite their benefits, biomass back pressure CHP plants do have a considerable footprint, necessitating time for the acquisition of suitable property. Taking these factors into account, the planning and regulatory process for a biomass back pressure CHP plant is estimated to span approximately 26 weeks. This duration places the planning process and regulatory approval within the medium range.

P6: Delivery time / availability of components and materials (Q)

The delivery time of all components and materials, for the construction of a new wood chip and straw-fired back pressure CHP plant, is expected to be approximately 91 weeks from the initial purchase date. For the wood pellet back pressure CHP plant, the timeframe is expected to be 78 weeks. This is because there is an ongoing supply chain shortage for electrical components and raw materials. The time estimates are based on previous experiences expressed by manufacturers constructing plants of similar capacity sizes. The timeframe for obtaining all the components for the wood pellet back pressure CHP plant is deemed to be shorter since

the process for handling wood pellets is simpler, meaning that less equipment is required.

Ukraine has a boiler manufacturing industry, producing one of the most advanced boilers for biomass burning up to 10 MWth in capacity. Additionally, larger boilers, ranging from 200-300 MW, are also produced in Ukraine, catering to both biomass and coal energy production.

P7: Requirements for logistics and transportation infrastructure (Q)

The unit, construction components, and fuel typically necessitate transportation via large equipment such as a semi-truck, train, or boat. This implies that the location of the biomass back pressure CHP plants should ideally be adjacent to a road, harbor, or railway. Consequently, the requirements for logistics and transportation infrastructure are categorized as "in between".

P8: Technical installation time (min time after clearance) (Q)

The anticipated installation time for the wood pellet back pressure CHP plants is 52 weeks. In contrast, the installation time extends to 65 weeks for wood chip back pressure CHP plants and further to 78 weeks for straw-fired back pressure CHP plants. This variation in installation time is primarily due to the complexities involved in handling different fuel types and introducing them into the plant's combustion chamber. For instance, conveying wood pellets into the combustion chamber is simpler compared to straw. Straw requires transportation via a conveyor belt or crane lift to be deposited into the combustion chamber through a hatch, while wood pellets can be injected via a screw pump.

P9: Requirements for skilled staff in construction phase (Q)

During the construction phase of a biomass back pressure CHP plant, a diverse workforce is required, including general laborers, heavy equipment operators, concrete workers, welders,

plumbers, electricians, HVAC technicians, and safety specialists. These workers can either be sourced locally in Ukraine or brought in from other countries, subject to company policies. If security concerns prevent companies from sending their employees to Ukraine, it is plausible that they might opt to train local laborers. Each medium-sized biomass back pressure CHP plant is unique and not based on modular builds, necessitating the presence of engineers during certain stages of construction to ensure quality control. Engineers are also required to modify building schematics if any aspect of the construction does not proceed as planned. This is a common issue for tailor-made plants, unlike modular build solutions which are well-tested. Consequently, the need for skilled staff during the construction phase is considered to be of 'medium' level.

According to information provided by the Ukrainian partners, Ukraine is facing a significant labor shortage, estimated to be up to 5 million workers, across all sectors due to the impacts of war and migration. This shortage is particularly noticeable in specialized fields such as biogas and biomethane installations, where there is a lack of qualified professionals. Therefore, it might be hard to source the number of laborers needed for a large construction project.

P10: Grid balancing capacity (/demands) (R)

Provided that biomass is readily available and the demand for heat is sufficient, a biomass back pressure CHP plant can generate electricity at any time of day. A cold startup, which involves gradually heating components to prevent thermal stress and damage, can take several hours. If the plant has not fully cooled down, it can undergo a warm startup, which is quicker and typically takes around 15 minutes. Compared to gas-fired power plants, biomass back pressure CHP plants take longer to ramp up their production.

Biomass back pressure CHP plants may influence the grid balance if they are disrupted

causing their production to cease abruptly. Given these factors, biomass back pressure CHP plants are expected to offer a medium level of grid balancing capability.

Taking the considerations above into account, Biomass back pressure CHP plants are expected to deliver a medium level of grid balancing capability.

P11: Requirements for electricity grid infrastructure (R)

As biomass back pressure CHP plants have a moderate electricity generation capacity, the requirement for the electricity grid infrastructure is medium, as these plants can be connected to the transmission grid or medium voltage grid.

P12: Requirements for skilled staff for operation and maintenance and for special spare parts (R)

Maintaining the operation of a biomass back pressure CHP plant requires a team of technicians specializing in operations, maintenance, instrumentation, electrical, and mechanical work. The need for full-time employment of these technicians can vary depending on the size of the plant, with some only required to address specific issues related to their field of expertise. However, operations technicians are essential for full-time roles, as they manage the plant from its control room. Compared to other technologies, the demand for skilled labor in this context is considered to be low.

P13: Possibility for camouflage and sheltering (R)

Camouflaging a biomass back pressure CHP plant is not feasible due to their large size and visibility via satellite imagery. While the majority of the plant cannot be sheltered, certain critical components, such as the transformer, can be reinforced or shielded with steel plating to mitigate damage from direct strikes. Given its relatively small size, the transformer can be effectively sheltered. Furthermore, it is worth noting

that this component is critical, and it could take up to a year or more to replace it if procured new from a supplier. Overall, the prospects for camouflage and sheltering are considered to be limited.

P14: Risk associated with fuel supply (R)

The majority of the biomass for the back pressure CHP plants is anticipated to originate from

Ukraine, which has a strong agricultural sector capable of producing substantial amounts of straw post-harvest. Additionally, the wood required for pellets and chips can be procured from Ukraine’s own forests, either through selective harvesting or the utilization of waste wood.

Criteria evaluation - Biomass CHP organic Rankine cycle

Criteria evaluation	7.b. Wood pellets, CHP Small	7d Wood Chips, CHP Small	7f Straw, CHP Small
Capacity in wintertime	WWW	WWW	WWW
Implementation speed	QQ	QQ	QQ
Technology resilience	RR	RR	RR
Levelized cost of electricity	C	C	C
General score (1-3)	2.0	2.0	2.0

Table 30: Criteria evaluation matrix for organic Rankine cycle plants, using wood pellets, wood chips and straw as fuel.

Winter impact, production at wintertime (W)

ORC CHP plants can contribute to the Ukrainian power system during wintertime. Furthermore, they can deliver heating to the local urban areas. ORC CHP plants can regulate their generation allowing them to produce at full capacity during wintertime. Although, the ORC CHP plants cannot scale their production as quickly as gas turbines or engines.

around 39 weeks, 52 weeks and 65 weeks for a wood pellet, wood chip and straw-fired ORC CHP plant. Accounting for planning and regulatory approvals, the overall project delivery time and the installation time, the project can be expected to respectively take 124 weeks for the wood pellet ORC CHP plant, 137 weeks for the wood chip ORC CHP plant and 150 weeks for the straw-fired ORC CHP plant. These timeframes are considered to lie within the medium timeframe.

Implementing speed (Q)

The timeline for the implementation of a biomass-fired ORC CHP plant hinges significantly on the project size. The planning process for such a plant is expected to be around 20 weeks and the time of delivery after the equipment for the biomass-fired ORC CHP plant has been ordered, is expected to be 65 weeks. Based on previous experiences the installation time is respectively estimated to take

Resilience (R)

The resilience of biomass ORC CHP plants is linked to two factors. Firstly, with a capacity being around 3MW, the plants can be dispersed throughout a broad geographic area, being able to deliver a combined sizeable production capacity, while having a medium effect on the balance of the power grid, in case one of the plants are struck with missiles, artillery or drones. Secondly, the footprint of a 3MW

biomass ORC CHP plants is fairly large in relation to its generation capacity, but a large part of the power plant can be bunkered.

Generation costs (LCOE), short term and over the lifetime (C)

In comparison to some of the other evaluated technologies, the LCOE of biomass ORC CHP plants is very high, when production is only available for two winters. Furthermore, The LCOE over the biomass ORC CHP plants lifetime is also very high. This is due to the

electrical efficiency of the technology, as it will consume more fuel per unit of electricity produced, thereby increasing the fuel costs considerably, in comparison to the biomass back pressure CHP plants.

Parameter evaluation – Organic Rankine cycle plants

This section covers the parameter evaluation of biomass-fired ORC CHP plants, which is used as the basis for the criteria evaluation.

Parameters	7.b. Wood pellets, CHP Small	7d Wood Chips, CHP Small	7f Straw, CHP Small
P1-Electricity production at wintertime	>75%	>75%	>75%
P2-Levelized Cost of Electricity (LCOE) short lifetime, winter production [€/MWh]	2277	2380	2491
P3-Levelized Cost of Electricity (LCOE) over lifetime [€/MWh]	250	242	246
P4-Distributed generation	3-3,15 MW	2,85-3 MW	2,95-3,10 MW
P5-Regulation requirement in the project development process	In between	In between	In between
P6-Delivery time and availability of components and materials	Lengthy and complicated	Lengthy and complicated	Lengthy and complicated
P7-Requirements for logistics and transportation infrastructure	Medium	Medium	Medium
P8-Technical installation time (after clearance)	Medium-term	Lengthy and complicated	Lengthy and complicated
P9-Requirements for skilled staff in construction phase	Medium	Medium	Medium
P10-Grid balancing capacity	Medium	Medium	Medium
P11-Requirements for electricity grid infrastructure	Easy	Easy	Easy
P12-Requirements for skilled staff for operation and maintenance and for special spare parts	Medium	Medium	Medium
P13-Possibility for camouflage and sheltering	Medium potential	Medium potential	Medium potential
P14-Risk associated with fuel supply	Low risk	Low risk	Low risk

Table 31: Parameter evaluation matrix of biomass-fired ORC CHP plants. The LCOE unit is [€/MWh].

P1: Electricity production at wintertime (W)

If there is fuel available, biomass ORC CHP plants may operate at their full capacity any

hour of the day, except for the planned and forced outages. Depending on the specific CHP plants there are different requirements for when the plant should be refurbished,

meaning that there will be some weeks of the year where it is planned that the biomass plants will be out of operation. Typically, the refurbishment is planned to be done during the summer, when the need for the plant is greatly lower. Forced outages can happen for multiple reasons, but typically occur due to some form of breakdown, which occurs during production.

As mentioned, the need for biomass CHPs is greatly lower during the summer as a large share of the electricity can be generated through baseload technologies like nuclear, wind and increasingly photovoltaics. Meanwhile the power consumption is also lower, as amongst other reasons, the heat demand is greatly reduced. Furthermore, biomass CHP plants also compete amongst each other and against other fuel-based power plants and combined heat and power plants, which means that some of the production will be cannibalized.

Due to these reasons, it is assumed that a biomass ORC CHP plant will operate, to what equates as, full capacity for 5.000 hours during a year, so-called Full Load Hours (FLH). As the majority of the production is likely to happen during the winter period, it is assumed that 75% of the FLH will occur during the wintertime, which means that it is assumed that a biomass CHP, will operate with 3.750 full load hours during wintertime (86% capacity factor). This corresponds to the annual FLH of a wind turbine, located in the Ukrainian region with the best wind profiles and above twice the annual FLH of a PV plant located in the Ukrainian region with the best solar profile. If Ukrainian power plants do not cannibalize on each other, due to missing capacity caused by Russian bombardments, then the FLH can be expected to be higher. Furthermore, biomass ORC CHP plants are expected to generate power in the intermediate and base load hours, which means that the FLH for biomass ORC CHP plants can be expected to be higher than gas engines and turbines.

P2: Levelized Cost of Electricity (LCOE) short lifetime, winter production (C)

In the emergency scenario, where the biomass ORC CHP plants is only utilized for two winter periods, the LCOE is amongst the highest prices. The LCOE is calculated to be 2280 €/MWh for a wood pellet plant, 2380 €/MWh for a wood chip plant and 2490 €/MWh for a straw-fired plant.

The majority of these costs are tied to the CapEx and finance costs, as the plants will not be able to deliver power for their full lifetime expectancy.

P3: Levelized Cost of Electricity (LCOE) over lifetime (C)

The LCOE over the wood pellet ORC CHP plants lifetime is expected to be approximately 250 €/MWh. The LCOE for the wood chip ORC CHP plants is calculated to be 240 €/MWh and for the straw/husk/stalks-fired ORC CHP plants it is calculated to be 245 €/MWh. For the wood pellet and wood chip CHP plant, this LCOE is considered to lie in the high price range. These prices are 5.5– 6 times higher than onshore wind power and 4 – 4.5 times higher than utility scale photovoltaics, and almost twice the price of new gas engines and turbines.

The cost allocation of the biomass ORC CHP plants is fairly spread out between the OpEx, fuel costs, CapEx and the finance costs. But the fuel cost, due to the electrical inefficiency of the ORC technology, does add a significant mark up on the price for these plants.

P4: Distributed generation (R)

The power generation capacity of the biomass ORC CHP plants is expected to be around 3 MW, which means that the biomass ORC CHP plants offer a choice of decentralized energy production. The distribution capability of biomass ORC CHP plants is therefore evaluated to be great.

Given the current situation in Ukraine, there are several compelling reasons to favor distributed installations. These installations, located near demand centers, offer the advantage of reducing dependence on the transmission grid, thereby mitigating the risks associated with potential power production capacity loss. Moreover, local power generation at the end-user's site diminishes the necessity for extensive electricity transmission, consequently bolstering energy security.

P5: Regulation requirement in the project development process (Q)

As the plants are around 3 MW capacity, they are not expected to have a large impact on the local environment, which means it can be assumed that the environmental approval process is easier. Furthermore, due to their relatively low capacity, it can be expected that the approval process for grid connection is also easier than larger power plants. Lastly, biomass ORC CHP plants come in modular builds, which are well known and can be pre certified for operation.

Due to these considerations the planning and regulation process for a biomass ORC CHP plant is expected to take around 20 weeks. This time consumption for the planning process and regulatory approval is in the medium range.

P6: Delivery time / availability of components and materials (Q)

The delivery time of all components and materials, for the construction of a new biomass ORC CHP plant, is expected to be approximately 65 weeks from the initial purchase date. This is because there is an ongoing supply chain shortage for electrical components and raw materials. The time estimates are based on previous experiences expressed by manufacturers constructing plants of similar capacity sizes. Due to the capacity size of the biomass ORC CHP plants, there is no expectation that fuel type will have an impact on the estimated delivery time.

P7: Requirements for logistics and transportation infrastructure (Q)

This unit and the components needed for the construction, as well as the fuel, typically requires transport by equipment of the size of a semitruck, train or a boat, which requires that the biomass ORC CHP plants is located beside a road, harbor or railway. Which means that the requirements for the logistics and transportation infrastructure is in the medium range.

P8: Technical installation time (min time after clearance) (Q)

The installation time for the wood pellet ORC CHP plants is expected to be 39 weeks. For the wood chip ORC CHP plant it's expected to be 52 weeks and for the straw-fired ORC CHP plants, it's expected to be 65 weeks. 39 weeks is categorized as a medium term for construction, whereas 52 weeks and above, is considered to be lengthy and complicated.

These installation times are within the parameters given in the Danish Technology Catalogue. But the difference in their installation time is attributed to the complexity of constructing the equipment handling the different fuel types and the equipment injecting the fuels into the plant's combustion chamber. I.e. it is easier to convey wood pellets into the combustion chamber than it is with straw. Straw needs to be transported via conveyor belt or lifted by crane, in order for it to be dumped into the combustion chamber via a hatch, whereas the wood pellets can be injected via a screw pump.

P9: Requirements for skilled staff in construction phase (Q)

During the construction phase, general laborers, heavy equipment operators, concrete workers, welders, plumbers, electricians, HVAC technicians and safety specialist workers are required. These laborer types should be available in Ukraine or can be sent from other countries, depending on company

policies. If companies cannot send their employees to Ukraine to perform the construction due to security concerns, it is reasonable to assume that some companies can and will educate general laborers from Ukraine. As each biomass-fired ORC CHP plant has an element to it, which is different from another ORC CHP plant, engineers are needed in some parts of the construction phase to oversee quality control. Furthermore, engineers are needed to adjust building schematics if something in the construction does not work as expected or properly. These are common issues for plants that are tailor made, in comparison to modular build solutions that are well tested. This is why the requirement for skilled staff is considered to be medium during the construction phase.

According to estimates provided by the Ukrainian partners, Ukraine is short of up to 5 million workers. Which means that during the construction phase, it might be hard to source the number of laborers needed for a large construction project.

P10: Grid balancing capacity (/demands) (R)

Assuming biomass is available, a biomass ORC plant can produce electricity at any hour of the day. It takes several hours to conduct a cold startup, as components need to be heated gradually to avoid thermal stress and damage as a result. If the plant has not completely cooled down, it can conduct a warm startup which takes less time than a cold startup, approximately 15 minutes. In comparison to gas-fired power plants, biomass ORC CHP plants are slower in ramping up their production.

Biomass ORC CHP plants have a production capacity which is too low to have any noticeable effect on the grid balance if they are bombarded and their production suddenly stops.

Taking the considerations above into account, Biomass ORC CHP plants are expected to deliver a medium level of grid balancing capability.

P11: Requirements for electricity grid infrastructure (R)

As ORC CHP plants have a low electricity generation capacity, the requirement for the electricity grid infrastructure is therefore low, as these plants can be connected to the medium voltage grid with a relatively small transformer.

P12: Requirements for skilled staff for operation and maintenance and for special spare parts (R)

To keep an ORC CHP plant in operation, operations-, maintenance-, instrumentation-, electrical- and mechanical technicians are required. Depending on the plant size, some of these technicians might not be needed for full-time employment but can be called in when there is a specific problem regarding their field of work. Operations technicians are needed for full-time employment, so they can operate the plant from its control room. The requirement for skilled labor is considered to be in the medium range, in comparison to other technologies, because the plant does have a size of around 3 MW which means there is some complicated work when maintaining the plant.

P13: Possibility for camouflage and sheltering (R)

There is some possibility for camouflaging ORC CHP plants. They are quite big, which might make them easy to spot, but their construction can be done so that they fit into the surroundings and the roofing can be covered with grass, which might make it harder for the Russians to spot the plant via arial footage. The smoke stack cannot be hidden, but the outlet can be placed further away from the rest of the plant.

Some parts of the biomass-fired ORC CHP plant cannot be sheltered, such as the smoke stack, but some critical components, such as the transformer, combustion chamber and generator, may be sheltered, to minimize the damage from a direct strike on the plant.

All in all, the possibility of camouflage and sheltering is considered to be medium.

P14: Risk associated with fuel supply (R)

The majority of the biomass for the ORC CHP plants, is expected to stem from Ukraine. Ukraine has a lot of agriculture, which can deliver large amounts of straw, af-ter each harvest. Furthermore, the wood for wood pellets and chips, can be sourced from Ukraines own forests, either through selective forest harvesting or use of waste wood.

Data sheet

In Appendix F are data sheets for

1. biomass CHP backpressure, medium scale for

- wood chips,
- wood pellets,
- straw/stalks/husk,

2. biomass CHP organic Rankine cycle, small scale for

- wood chips,
- wood pellets,
- straw/stalks/husk

Hydro Power

Capacity
in wintertime



Implementation
speed



Technology
resilience



Levelised cost
of electricity



General score:



HYDROPOWER

The rating on the frontpage shows the score for the technology achieving the highest general score among the sub technologies evaluated in the chapter. The more icons the better performance¹⁸. For the hydro power, it is the Hydro, RoR, micro which achieve the best score. It

should be noticed that no LCOE calculation are available for the “Retrofit of HPPs with dams incl. PHS”, thus the technology could have the highest score. The scores for all sub-technologies are shown in Table 32.

Criteria evaluation	8.a. Hydro, RoR, small	8.b. Hydro, RoR, micro	8.c Retrofit of HPPs with dams incl PHS
Capacity in wintertime	WW	WW	WWW
Implementation speed	Q	QQ	Q
Technology resilience	RR	RR	RR
Levelized cost of electricity	CCC	CCC	n.a.
General score (1-3)	2.0	2.3	n.a.

Table 32:Hydropower - overall criteria matrix for hydropower technologies.

This section covers the small-scale hydro generator types with the capability of being more distributed to supply Ukraine with electricity in case the largescale hydropower generation facilities are attacked by aggressors. The types of hydro generators concerned in this section are the following:

- Micro generators ranging from few kilo watts to 1 MW.
- Small generators ranging from 1 MW to 25 MW.
- Retrofit of existing HPPs with dams and pump storage.

¹⁸ See detailed explanation in Table 2: Overview of which parameters contribute to which criteria and visualizing of the ratings, the more icons the better rating.

Brief technology description

Hydropower has been a reliable and proven method for electricity production for more than hundred years. Application of hydropower for providing power to various human activities have been observed for several thousand years.

The hydropower concept exploits the head difference between two water reservoirs, be it natural or artificially created through dams and weirs. In a hydropower plant, the potential energy is converted into rotational kinetic energy, which spins the blades of a turbine connected to a generator. In total hydro power provides approximately 10% of the total installed generation capacity.

Hydropower plants can be classified in different ways, which for instance distinguish among head availability, plant size and operational regime. In terms of operational regime, the following classification is widely accepted (ref. 1):

Run-of-river (RoR) Hydro Power Plants.

A facility that channels flowing water from a river through a canal or penstock to spin a turbine. Typically, a run-of-river project has little or no storage facility. They are typically small and find application also in off-grid contexts.

A scheme for a RoR hydro power plants is presented in Figure 26 below.

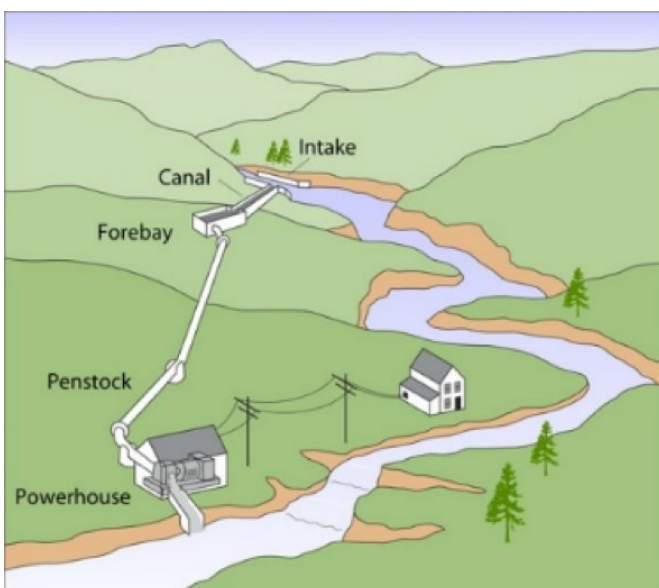

Figure 26: Run-of-river hydropower plant schematics (ref. 2, 3).

Storage/reservoir Hydro Power Plants. Uses a dam to store water in a reservoir (water impoundment). Electricity is produced by discharging water from the reservoir through a turbine, which activates a generator. They can span over a wide range of capacities, depending on the hydraulic head and reservoir size.

A scheme for a hydro power plant with dam is presented in Figure 27.

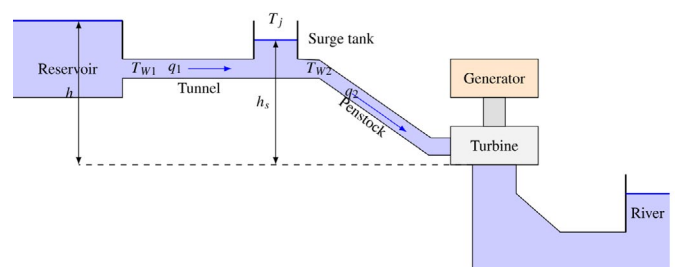

Figure 27: Reservoir hydropower plant schematic (ref. 2, 3).

Run-of-river and reservoir hydropower plants can be combined in cascading river systems and pumped storage hydro plants can utilize the water stored in one or several reservoir hydro power plants. In cascading system principle (Figure 28), the energy output of a run-of-river hydro power plant can be regulated by an upstream reservoir hydro power plant. A large reservoir in the upper catchment generally regulates outflows for several run-of-rivers or smaller reservoir plants downstream. This likely increases the yearly energy potential of downstream sites and enhances the value of the upper reservoir's storage function. However, this also creates the dependence of downstream plants to the commitment of the upstream plants. Forecasting of output from the various cascaded HPPs can be accurate as water flow measurements in the first HHP can be applied in calibrating the forecasting algorithm for all cascading power plants. As water cannot be compressed and a known part is evaporating or diverting the time schedule for the cascading plants can be forecasted accurate. In UA is two different cascading systems, namely, the Dnipro cascade (total of 9.900 MW) and the Dniester cascade (total of 730 MW)

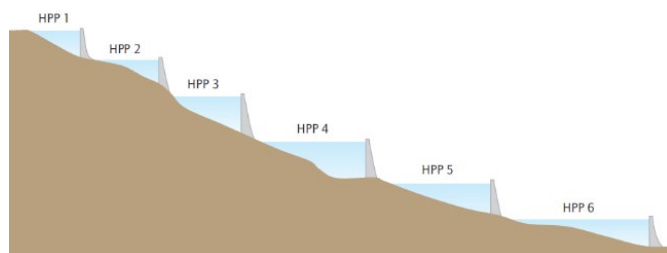

Figure 28: Cascading System principle (ref. 4)

Pumped Hydro Storage power plants. Provides peak load supply, harnesses water which is cycled between a lower and upper reservoir by pumps which use surplus energy from the electrical system at times of low demand and low costs. While plenty of pumped hydro storage plants exist and are under construction in the world, Ukraine has few of these facilities. The Kyiv Pumped-Storage Power Plant (235 MW), the Dniester Pumped Storage Power Station (972 MW) and the Tashlyk Pumped-Storage Power Plant (302 MW) in total a capacity of 1.509 MW.

A scheme for Pumped Hydro Storage power plants is presented in Figure 29.

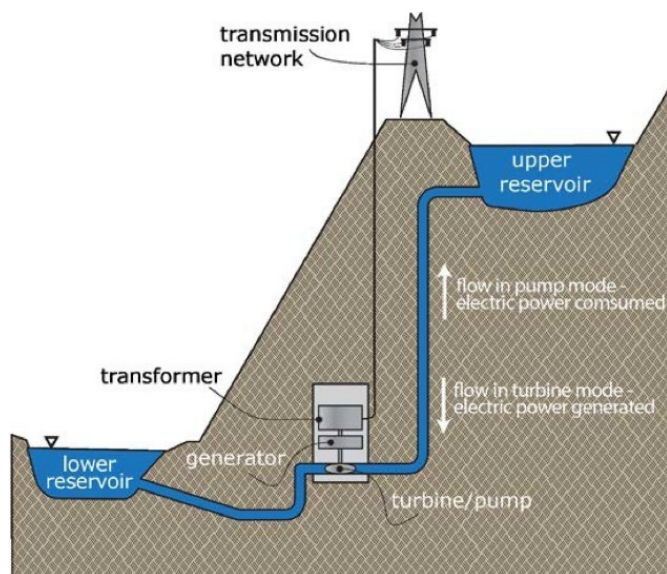

Figure 29: Pumped Hydro Storage power plant (ref. xx).

Pumped Hydro Storage (PHS) are one of the key balancing means to adapt variable renewable energy resources like solar, wind and run off river power generation as well as preserving the dynamic stability of the grid system in

low demand scenarios e.g. during nighttime and/or operating the grid system in intentional islanding for increasing the resilience to attacks.

Hydro power plants are ranging from kilo Watts to hundreds of Mega Watts. A classification based on the size of hydro power plants is presented in Table 33 (ref. 1).

Type	Capacity (international classification)
Large hydropower	> 100 MW
Medium hydropower	25 – 100 MW
Small hydropower	1- 25 MW
Mini/micro hydropower	< 1 MW

Table 33: Classification of hydropower plants based on capacity size.

Large hydropower plants often have outputs of hundreds or even thousands of megawatts and use the energy of falling water from the reservoir to produce electricity using a variety of available turbine types (e.g., Pelton, Francis, Kaplan) depending on the characteristics of the river, the hydraulic head and installation capacity. Small, micro hydropower plants are run-of-river schemes. These types of hydropower use Cross-flow, Pelton, or Kaplan turbines.

For high heads and small flows, Pelton turbines are used, in which water passes through nozzles and strikes spoon-shaped buckets arranged on the periphery of a wheel. A less efficient variant is the crossflow turbine. These are action turbines, working only from the kinetic energy of the flow.

For low heads and large flows, Kaplan turbines, a propeller-type water turbine with adjustable blades, dominate. Kaplan and Francis turbines, like other propeller-type turbines, capture the kinetic energy and the pressure difference of the fluid between entrance and exit of the turbine. Francis turbines are the most common type, as they accommodate a

wide range of heads (20 m to 700 m), small to very large flows, a broad rate capacity and excellent hydraulic efficiency.

The selection of the turbine type depends on the net head defined on Figure 30 and the flow rate of the river.

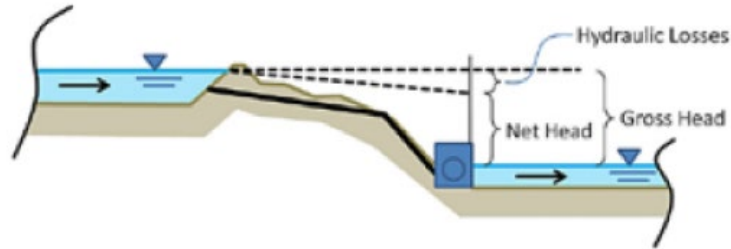

Figure 30: Hydro Power – definition of net and gross head (ref. 5)

The hydro power turbine application chart related to the net head and the flow rate of the river, is depicted in Figure 31.

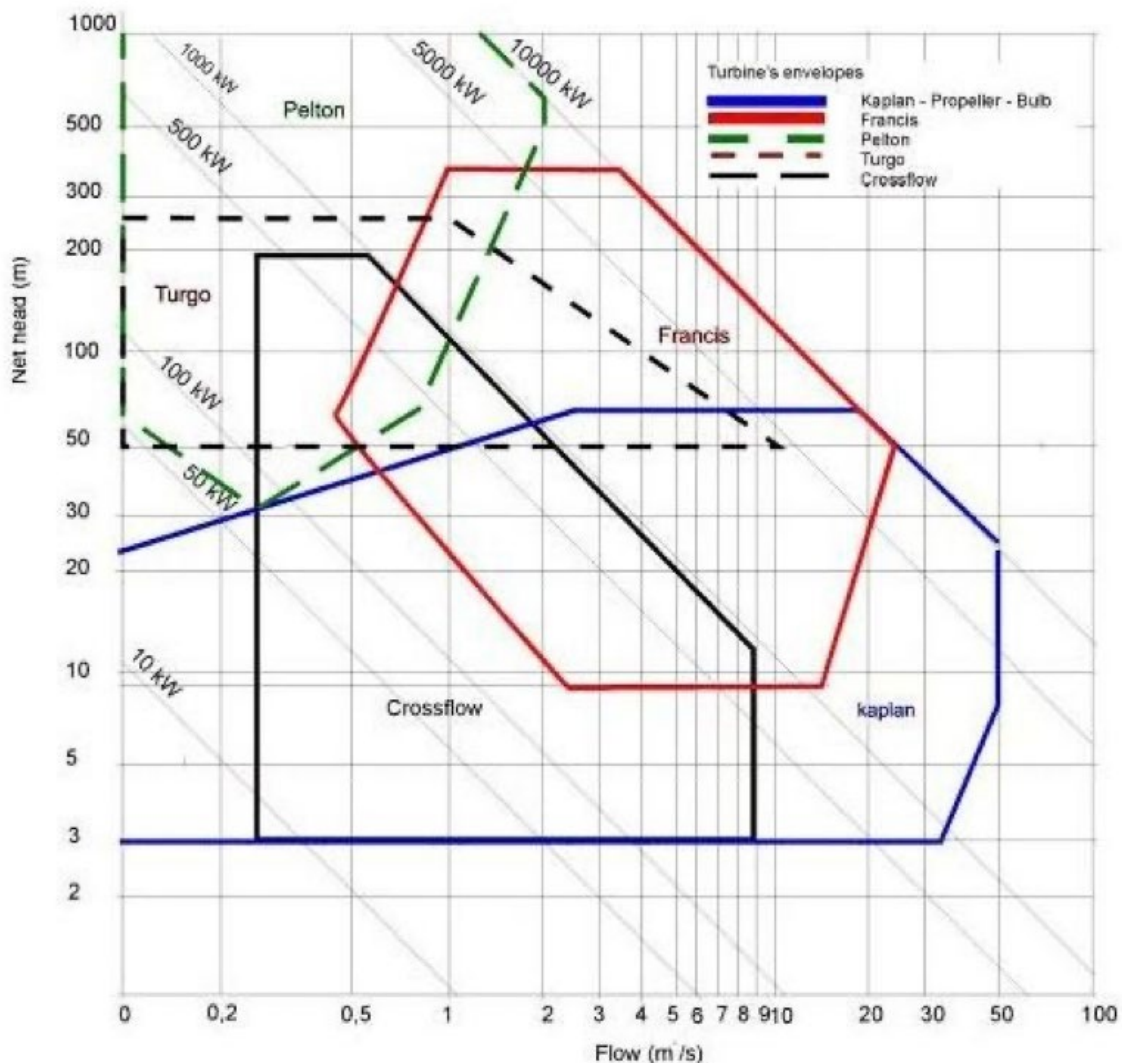

Figure 31: Hydropower turbine application chart (ref. 5)

The capacity factor achieved by hydropower projects needs to be looked at somewhat differently than for other generation projects. It depends on the availability of water and the purpose of the plants whether for meeting peak and/or base demand.

The average capacity factor of hydropower plants settled at 48% in 2010-2019 (world -wide figures), with a significant standard deviation across geography. The blue areas in the figure represent the standard deviation from the average (Figure 32).

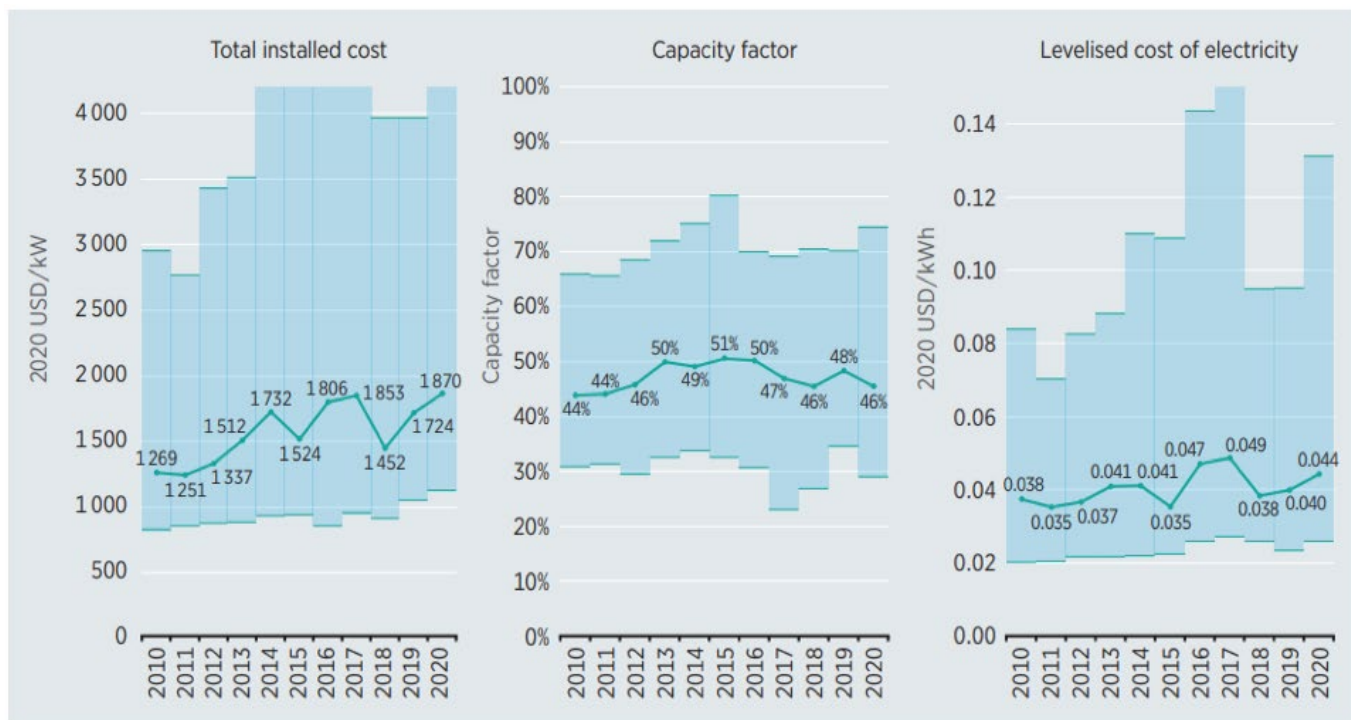

Figure 32: Total inst. cost, capacity factor, LCOE for hydropower (world) (ref. 6).

According to Ukrhydroenergo the following hydro power plants are currently in operation in Ukraine see Table 34. As a note the turbine technology is indicated.

Name	Location	Technology	Power (MW)	Year built	Note
<u>Dnieper Hydroelectric Station</u>	<u>Zaporizhzhia</u>	HPP	1,548	1927–1939; 1969–1980	Francis
<u>Dniester Hydroelectric Power Plant</u>	<u>Novodnistrovsk</u>	HPP	702	1973–1981	Kaplan
<u>Dniester Pumped Storage Power Station</u>		PHS	972	1983–2015	Francis
<u>Kyiv Hydroelectric Power Plant</u>	<u>Vyshhorod</u>	HPP	388.8	1964	Bulb
<u>Kyiv Pumped Storage Power Plant</u>		PHS	235	1970	Francis

Name	Location	Technology	Power (MW)	Year built	Note
<u>Kaniv Hydroelectric Station</u>	<u>Kaniv</u>	HPP	444	1972	
<u>Kaniv Pumped Storage Power Station [uk]</u>	<u>Buchak, Kaniv [uk]</u>	PHS	1,000	1986–1991; 2019–? (under construction)	Propeller
<u>Kremenchuk Hydroelectric Station</u>	<u>Svitlovodsk</u>	HPP	625	1959	Propeller
<u>Kakhovka Hydroelectric Station</u>	<u>Nova Kakhovka</u>	HPP	351	1950-1956	Destroyed 6 June 2023
<u>Middle Dnieper Hydroelectric Power Plant</u>	<u>Kamianske</u>	HPP	352	1963	Propeller
<u>Tashlyk Pumped-Storage Power Plant</u>	<u>Yuzhnoukrainsk</u>	PHS	302	1981-2007	Francis

Table 34: List of hydro power plants in UA HPP: Hydro Power Plant with dam; PHS: Pump Hydro Storage Power Plant; RoR: Run of River (without a dam)- variable like wind and solar.

Retrofit of HPPs with dams and pumped hydro storage

- Information exchange and data communications aspects are already in place

Retrofitting and/or upgrading of existing hydro-power facilities have a lot of quick wins and a series of low hanging fruits to be harvested. The following quick wins among others can be mentioned:

Retrofitting existing facilities can be very attractive in time for implementation as well as limited involved cost.

- The facilities are already grid connected
- The facilities are already commissioned and operative
- The facilities are already staffed
- All operational and security procedures are in place

Criteria evaluation – hydro power

This section covers the selected criteria evaluation of hydro power, which are intended for use as a guidance for selecting the most appropriate generation technology in the actual situation.

Criteria evaluation	8.a. Hydro, RoR, small	8.b. Hydro, RoR, micro	8.c Retrofit of HPPs with dams incl PHS
Capacity in wintertime	WW	WW	WWW
Implementation speed	Q	QQ	Q
Technology resilience	RR	RRR	RR
Levelized cost of electricity	CCC	CCC	CCC
General score (1-3)	2.0	2.5	2.3

Table 35: Criteria evaluation matrix of hydro power plants

The criteria evaluation is based on the parameter evaluation in section below.

Winter impact (production at wintertime)

Hydro Power Plants can contribute to the Ukrainian power system during wintertime as long as the minimum required water stream is available.

HPPs can regulate their generation allowing them to produce at full capacity during wintertime and add essential stability services as well as system inertia inherently provided by the synchronous generator technology.

Most of the micro hydro generators are based on non-synchronous technology and as such are lacking the capability for providing some of the stabilizing services as well as adding value to the system inertia.

Nearly all hydropower generators with a nominal capacity above 1 MW are based on synchronous technology and as such have the build-in capability to provide the minimum required stabilizing services as well as contributing to the system inertia.

Retrofit of existing hydropower facilities might be required to provide the required frequency service capability.

Implementing speed

The timeline for the implementation of a hydro power plant is highly depending on the facility size. Micro or small-scale facility sizes are quicker to implement than medium or large facilities as the components might be on the shelf.

Retrofit of existing facilities are comparable to implementation of small-scale and medium scale facilities if not quicker depending on the parts for retrofit. In the parameter evaluation the group 8.a and 8.c have the same estimated

project time of 136 weeks. The estimated project time for micro hydro facilities is 104 weeks. The variability of the estimated project time can be huge as local issues and supply chain issues can vary from area to area and time to time.

Resilience

The resilience of hydro power plants is linked to local issues of the topology of the water stream and the landscape. If the hydro power generators can be dispersed into smaller units and hidden along the water stream and being able to deliver a combined sizeable production capacity it will increase the resilience of the complete facility.

In case the landscape provides natural bunkering of large parts of the hydro power plant the resilience will be increased as well.

Using underground cabled wiring to transmit the power from the facility instead of overhead lines will also increase the resilience against aggressive attacks and sabotage.

Generation costs (LCOE), short term and over the lifetime

In comparison to the other evaluated technologies, the LCOE of hydropower plants are in general lower for micro and small-scale HPPs if their production is only available for two winters. Furthermore, the LCOE for HPPs are very low compared to other technologies as the fuel has no cost and the lifetime of HPP facilities are normally high. The global LCOE evolution through 2010 – 2020 for HPPs are depicted in Figure 32.

Parameter evaluation – hydro power

This section covers the parameter evaluation of hydropower, which are used as the basis for the criteria evaluation.

Parameters	8.a. Hydro, RoR, small	8.b. Hydro, RoR, micro	8.c Retrofit of HPPs with dams incl PHS
P1-Electricity production at wintertime	50%	50%	>75%
P2-Levelized Cost of Electricity (LCOE) short lifetime, winter production [€/MWh]	1008	1350	n.a
P3-Levelized Cost of Electricity (LCOE) over lifetime [€/MWh]	64	74	n.a.
P4-Distributed generation	10-100 MW	0-10 MW	100 MW
P5-Regulation requirement in the project development process	Lengthy	In between	Lengthy
P6-Delivery time and availability of components and materials	In between	In between	In between
P7-Requirements for logistics and transportation infrastructure	Medium	Low	Medium
P8-Technical installation time (after clearance)	Medium-term	Medium-term	Medium-term
P9-Requirements for skilled staff in construction phase	Medium	Medium	Medium
P10-Grid balancing capacity	Medium	Low	Low
P11-Requirements for electricity grid infrastructure	Moderate	Moderate	Low
P12-Requirements for skilled staff for operation and maintenance and for special spare parts	Low	Low	Low
P13-Possibility for camouflage and sheltering	High potential	High potential	Medium potential
P14-Risk associated with fuel supply	Low risk	Low risk	Low risk

Table 36: Parameter evaluation matrix of hydro power plants. The LCOE unit is [€/MWh].

P1: Electricity Production at Wintertime (W)

Hydro Power Plants can contribute to the Ukrainian power system during wintertime as long as the minimum required water stream is available. Therefore, it is estimated that the RoR plants are able to deliver at least 50 % of the capacity during the wintertime. While HPPs can regulate their generation allowing them to produce at full capacity during wintertime and add essential stability services as well as system inertia inherently provided by the synchronous generator technology.

Most of the micro hydro generators are based on non-synchronous technology and as such are lacking the capability for providing some of the stabilizing services as well as adding value to the system inertia.

Nearly all hydropower generators with a nominal capacity above 1 MW are based on synchronous technology and as such have the build-in capability to provide the minimum required stabilizing services as well as contributing to the system inertia.

Hydropower generation facilities with modern control capability are normally able to provide Frequency Containment Reserve services (FCR) as well as Frequency Restoration Reserve services (FRR) and Replacement Reserve services (RR). Retrofit of existing hydropower facilities might be required to provide the required frequency service capability.

P2: Levelized Cost of Electricity (LCOE) Short Lifetime, Winter Production (C)

In comparison to the other evaluated technologies, the LCOE over 2 years of wintertime

production for the RoR hydropower plants are lower than 80 % of the average for the other evaluated technologies. This is because the fuel has no costs and the investment costs are moderate. No LCOE has been calculated for the retrofitting of HHP with dams and PHS due to lack of data.

P3: Levelized Cost of Electricity (LCOE) Over Lifetime (C)

In comparison to the other evaluated technologies, the LCOEs over the lifetime production for the RoR hydropower plants are lower than 80 % of the average for the other evaluated technologies. This is because the fuel has no costs, the investment cost is moderate and the lifetime of HPP facilities is long. No LCOE has been calculated for the retrofitting of HHP with dams and PHS due to lack of data. However, examples of calculations of LCOE evolution for the through 2010 – 2020 for HPPs are depicted in Figure 32.

P4: Distributed Generation (R)

Micro RoR HHP is given the best assessment in relation to the possibility of distributed production. While small HHP RoR and HHP with dams and PHS are assessed to be medium in relation to the parameter “distributed production”.

In general, smaller distributed units are more resilient than large, centralized units. Several examples of the high risk with large centralized system can be given e.g. the captive of the Zaporizhzhia NPP facility and the sabotage of the Kakhovka HPP facility in 2023. Globally a long list of high risks related to large generation facilities could be mentioned. That’s why a more distributed approach is recommended in UA with an increase in resilience as the outcome.

P5: Regulation Requirement in the project development process (Q)

UA regulation on Environmental Assessment shall be applied to a project.

For grid connection the UA implementation of the EU grid connections network code for all generators according to the EU 631/2016 shall apply to all new installations.

For facility operation the UA implementation of the EU regulation for transmission system operational guideline Commission Regulation (EU) 2017/1485 and the Network code for Emergency and Restoration, the EU 631/2016 shall apply to all new installations.

For market operation the UA implementation of the COMMISSION REGULATION (EU) 1222/2015 of 24 July 2015 establishing a guideline on capacity allocation and congestion management and the FCA – the UA implementation of the Commission Regulation (EU) 2016/1719 of 26 September 2016 establishing a guideline on forward capacity allocation and the EB guideline the UA implementation of the Commission Regulation (EU) 2017/2195 of 23 November 2017 establishing a guideline on electricity balancing shall apply to all new installations.

From this, it is estimated that the periods for obtaining permits are 48, 26 and 52 weeks for respectively small and micro RoR hydro power plants and hydro power w. dams and PHS.

6: Delivery Time/Availability of Components and Materials (Q)

The delivery time of all components and materials, for retrofit of hydro power plant, is expected to be approximately 36 weeks from the initial purchase date. This is because there is an ongoing supply chain shortage for electrical components, where some of the components take between 26-52 weeks to be delivered, but it is expected that during the refurbishment or repairs, only some components will be newly produced, and this varies between the plant. So, in general it is expected to take 36 weeks to source the components for the different plants.

P7: Requirements for Logistics and Transportation Infrastructure (Q)

The transportation of components for the hydro power plant do to some extent require transportation by train, boat or special vehicles, equipment, or routes. The logistics and transportation infrastructure in Ukraine may pose some challenges due to poor road conditions in some areas, damages to railways, ports and cranes, and security risks in war areas.

Railways and the ports have been heavily damaged, and shipments that used to come through the Black Sea have become nearly impossible.

This means that the refurbishment or repair of HPP and Small RoR HPP have medium evaluations for the need for logistics and transportation infrastructure. While micro RoR HPP is given the best evaluations for the need for logistics and transportation infrastructure.

Ensuring access to adequate transport infrastructure may be a critical parameter in the process of identifying sites for HPPs especially for not micro scale plants.

P8: Technical Installation Time (Min Time After Clearance) (Q)

The installation time for the hydropower plants is expected to be 36, 26 and 48 weeks for respectively small and micro RoR hydro power plants and hydro power w. dams and PHS.

P9: Requirements for Skilled Staff in Construction Phase (Q)

No special requirements for the staff of hydropower facility are required expect all skills for building and construction according to the current UA legislation.

P10: Grid Balancing Capability (R)

All minimum grid connection requirements for functionality and parameter ranges are stated in the UA implementation of the EU grid

connections network code for all generators according to the Commission Regulation (EU) 2016/631 of 14 April 2016 establishing a network code on requirements for grid connection of generators.

HPPs with dams and PHS can regulate their generation and thereby add essential stability services as well as system inertia inherently provided by the synchronous generator technology.

Most of the micro hydro generators are based on non-synchronous technology and as such are lacking the capability for providing some of the stabilizing services as well as adding value to the system inertia.

Nearly all hydropower generators with a nominal capacity above 1 MW are based on synchronous technology and as such have the built-in capability to provide the minimum required stabilizing services as well as contributing to system inertia.

Hydropower generation facilities with modern control capability are normally able to provide Frequency Containment Reserve services (FCR) as well as Frequency Restoration Reserve services (FRR) and Replacement Reserve services (RR). Retrofit of existing hydropower facilities might be required to provide the required frequency service capability.

P11: Requirements for Electricity Grid Infrastructure (R)

As the hydropower plants of micro and small-scale have a moderate electricity generation capacity, the requirement for the electricity grid infrastructure is low or medium, as these plants can be connected to the distribution grid system at the medium voltage level. Voltage levels are not essential for grid stability so if a transmission line is passing the hydropower facility, it can be connected to the transmission grid system if it fulfils the minimum connection requirements in the UA implementation of the EU grid connections

network code for all generators according to the EU regulation 631/2016.

P12: Requirements for Skilled Staff for Operation and Maintenance and for Special Spare Parts (R)

No special requirements for the staff of hydropower facility except an understanding of the operational concept and a required qualification according to the UA implementation of the EU regulation for transmission system operational guideline Commission Regulation (EU) 2017/1485 and the Network code for Emergency and Restoration.

P13: Possibility for Camouflage and Sheltering (R)

The resilience of hydro power plants is linked to local issues of the topology of the water stream and the landscape. If the hydro power generators can be dispersed into smaller units and hidden along the water stream and then being able to deliver a combined sizeable production capacity it will increase the resilience of the complete facility.

In case the landscape provides natural bunkering of large parts of the hydro power plant the resilience will be increased as well.

Using underground cabled wiring to transmit the power from the facility instead of overhead lines will also increase the resilience against aggressive attacks and sabotage.

P14: Risk Associated with Fuel Supply (R)

As the UA river system of Dnieper as well as Dniester is collecting water from diversified areas with a large topographical variation the water level available for the various HPPs is evaluated not to have a big diversity, so this risk is low. In addition, requirements for farming irrigation bindings are neglectable or not existing. So, in conclusion, the fuel supply for hydropower does exist all year round.

An example of the rich water resources of the Dniester Hydro Power Complex with more than 15 rivers providing water for the generation facilities is depicted in Figure 33.

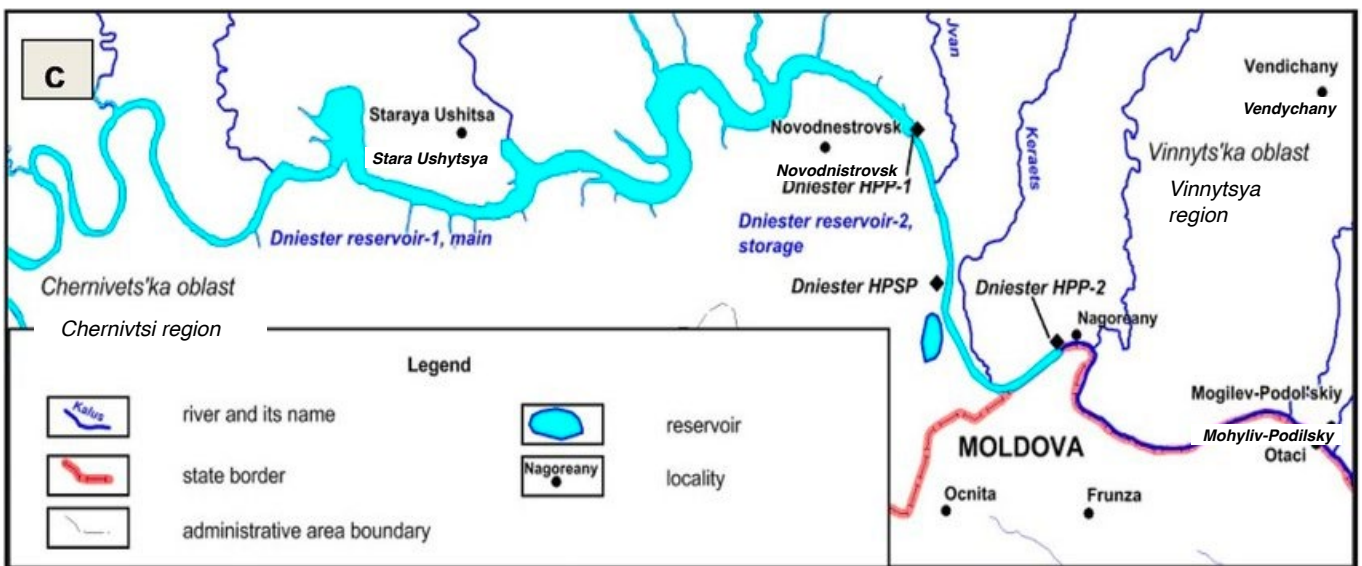

Figure 33: Dniester Hydro Power Complex, ref. [21].

Another example of the very rich water resources is the Dnieper River system. More than 89 rivers are providing water for the Dnieper River basin and the Dnieper Cascading

System with 6 HPPs involved. The Dnieper River dams, and cascading system is depicted in Figure 34.



Figure 34: Dnieper river dams and cascading system ref. [21]s.

Data sheet
In Appendix F

REFERENCES

- [1] “Nag, ‘Power plant engineering’, 2009 - Google Scholar.” Accessed: Oct. 16, 2023. [Online]. Available: https://scholar.google.com/scholar?hl=en&as_sdt=0%2C5&q=Nag%2C+%E2%80%9CPower+plant+engineering%E2%80%9D%2C+2009&btnG=
- [2] G. Fitzgerald, J. Mandel, J. Morris, and H. Touati, “The Economics of Battery Energy Storage - How Multi-use, Customer-sited Batteries Deliver the Most Services and Value to Customers and the Grid,” 2015.
- [3] K. Takei et al., “Cycle life estimation of lithium secondary battery by extrapolation method and accelerated aging test,” in *Journal of Power Sources*, 2001. doi: 10.1016/S0378-7753(01)00646-2.
- [4] Y. Nishi, “Lithium ion secondary batteries; Past 10 years and the future,” *J Power Sources*, vol. 100, no. 1–2, 2001, doi: 10.1016/S0378-7753(01)00887-4.
- [5] H. C. Hesse, M. Schimpe, D. Kucevic, and A. Jossen, “Lithium-ion battery storage for the grid - A review of stationary battery storage system design tailored for applications in modern power grids,” *Energies*, vol. 10, no. 12. 2017. doi: 10.3390/en10122107.
- [6] “Biogas Technology and Biomass, Renewables Academy,” Berlin, Germany.
- [7] “Jorgensen, 2009. Biogas – green energy, Faculty... - Google Scholar.” Accessed: Oct. 16, 2023. [Online]. Available: https://scholar.google.com/scholar?hl=en&as_sdt=0%2C5&q=1.%2009Jorgensen%2C+2009.+Biogas+%E2%80%93+green+energy%2C+Faculty+of+Agricultural+Sciences%2C+Aarhus+University%2C+2nd+edition%2C+Denmark&btnG=
- [8] “Danish Climate Strategy,” Copenhagen, Denmark, 2003.
- [9] DECC, “Electricity Generation Costs (December 2013),” 2013.
- [10] R. M. Ambrosini, “Life extension of coal-fired power plants.,” 2005.
- [11] Veringa, H. and P. Alderliesten. Veringa, “Advanced techniques for generation of energy from biomass and waste,” 2004.
- [12] G. Simbolotti, “Biomass for power generation and CHP,” 2007.
- [13] Danish Energy Agency, “Technology data Generation of Electricity and District heating, 2023.
- [14] International Finance Corporation, *Hydroelectric power*, 201
- [15] Department of Energy, USA, www.energy.gov/eere/water/types-hydropower-plants Accessed: 20th July 2017
- [16] Gil-González, W. et al., Passivity-based control and stability analysis for hydro-turbine governing systems, *Applied Mathematical Modelling*, 68 (2019), pp. 471-486.
- [17] IEA, 2012. *Technology Roadmap Hydropower*, International Energy Agency, Paris, France
- [18] Sangal Saurabh et al., Review of optimal selection of turbines for hydroelectric projects, *International Journal of Emerging Technology and Advanced Engineering*, 2013.
- [19] IRENA. (2021). *Renewable power generation costs in 2020*. www.irena.org
- [20] *Hydropower on the Mississippi River*, July 2017, Conference: Raising the Grade on the Upper Mississippi River - Hydro Potential on the Mississippi River, At: Moline, IL
- [21] Large and small reservoirs of Ukraine Valentyn Khilchevskyi, Vasyl Grebin, Sergiy Dubniak, Myroslava Zabokrytska, Hanna Bolbot

APPENDIX A: METHODOLOGY

Description of the new 14 parameters and how they are evaluated

The following subsections will delve into the underlying reasons for addressing each parameter in this technology catalogue and how they influence the implementation of power generation projects in the current Ukrainian context. Following this, we will explore the three-level assessment scale specific to each of these parameters.

P1: Electricity production at wintertime

Electricity production at wintertime, is defined as production between October and March including both months (4368 hours all in all).

This technology catalogue is to high extend concerned about the ability to generate electricity during wintertime. Ukraine has higher electricity demand, and it is needed for more critical functions in winter compared to summer and thus it is more challenging to cover demand during wintertime and to some extent more important that it is covered.

Technologies that do not contribute much to electricity generation at wintertime (e.g., solar power) will require the system to have an

alternative generation capacity to cover the missing capacity. Technologies that have reduced generation during wintertime either due to fuel shortage or due to being intermittent in nature with less natural resources in winter (e.g., solar power) will add a burden of increasing firm capacity of the power system to ensure security of supply at wintertime.

This qualitative parameter will be assessed on three-level scale, assessing the potential of each technology for generating electricity at wintertime as having:

- Good: High potential, the ability to deliver more than 75 % of the annual capacity factor during winter times; **preferred**
- Medium: Moderate potential, the ability to deliver more than 40% and less than 75 % of the annual capacity factor during winter times.
- Bad: low potential: the ability to produce less than 40% of the annual capacity factor during winter times.

P2: Levelized Cost of Electricity (LCOE) short time and winter production and P3: LCOE over the technical lifetime and total production

LCOE is used for assessing the value of the technology to be able to evaluate the cost efficiency of installing the technology.

Two different LCOEs are calculated for each sub-technology:

1. LCOE short time and winter production. LCOE is calculated for the production over the lifetime and only for the production in wintertime. The cost of the CO₂ emissions is not included in this calculations.
2. A general LCOE calculated over the full lifetime and for full lifetime production.

Because of the current situation in UA it is valuable to know the cost efficiency both in the critical situation. Here it is the production at wintertime that is crucial and the technology is set up knowing that it will maybe only be operating for two years. There is also a chance that the technology will be in operation its full lifetime, therefore it is also interesting to analyze the LCOE over the full lifetime.

Levelized Cost of Electricity (LCOE) is used for assessing and comparing unit cost (€/kWh) of generating electricity using different technologies. The calculation of the LCOE is based on the equivalence of the present value of the sum of discounted revenues and the present value of the sum of discounted costs. LCOE considers all costs associated with building, operating, and maintaining a power generation plant over its expected lifetime or another defined period. The LCOE calculations are described in details in appendix B.

The LCOE is a qualitative parameter and is used for assessing the technologies on three-level scale, the thresholds will be defined according to the distribution of the plants included, and will of course differ between the short time winter production LCOE and the lifetime LCOE:

- Good: Technologies with low LCOE, more than 25 % lower than average; **preferred**
- Medium: Technologies with medium LCOE less than or 25 % lower and more than or 25 % higher than average
- Bad: Technologies with high LCOE more

than 25 % higher than average

A CO₂ cost of 80 €/ton is considered in the LCOE calculations corresponding to the current (Oct. 2023) price of CO₂-allowances in the EU ETS.

P4: Distributed generation

The property of being able to produce at a distributed scale is evaluated. Because under the current situation in Ukraine, the property can mitigate the risks of losing significant power production capacity, thus seen as more favored.

A significant number of large power plants, substations and grid have been targeted with air strikes, leading power loss for many consumers.

The reasons for the assumption of higher robustness for delivering power in the current situation for In Ukraine for distributed technologies are:

- could be located near demand centers, reducing reliance on the transmission grid
- the interest in destroying the plant is assumed to be dependent on how much capacity can be taken out of operation for each impact point

This parameter “applicable for distributed operation” is assessed on a three-level scale, assessing the typical size of each technology to be used as distributed generator as technologies with typical capacities:

- Good: Technologies with capacities below 5 MW. For the scope of this technology catalogue, technologies with typical capacities below 5 MW are **preferred**
- Medium: Technologies with capacities between 5-20 MW
- Bad: Technologies with capacities between 20-60 MW

P5: Regulation requirement in the project development process

Before the actual construction of the power

generation technology can begin, it may in many cases be necessary to obtaining permits, conducting comprehensive environmental studies, and performing various assessments such as soil analysis, solar radiation evaluation, and wind condition examinations. After that, financing agreements must be secured. All in all, this can lead to significant time consumption. Furthermore in general, the UA implementation of the EU requirements for all generators must be followed.

These sequential tasks significantly influence the overall timeline from project conception to commission. Hence, it is essential to develop a comprehensive timeline that outlines the anticipated duration required for these processes. This parameter is assessed on three-level scale, assessing the speed and the simplicity of the process under:

- Good: quick and easy process, less than three month; **preferred**
- Medium: in between process, between three month and 9 months
- Bad: lengthy and complicated process, more than 9 months

P6: Delivery time / availability of components and materials

The delivery time and availability of power plant components are crucial for a quick installation. Therefore, it is crucial to account for the availability of required technology, components and materials (e.g. steel and cement) when considering the timeframe on constructing power generation plants.

Essential materials such as steel and cement may be scarce and compete with defense-related purposes for their use in the installation of power-generating technologies.

The time for manufacturing the component or the whole plant of the technology impacts the delivery time, but the capacity to manufacture plants and components for Ukraine may be limited by a high demand in general.

Some systems and components for systems are only produced on demand and are not available in stock. But the delivery time can be considerable reduced if a storage of already produced components or plants exist (which e.g. is the case for PV modules) or it is possible to buy second hand plants. In the same way, it could be possible to reduce the delivery time considerable for components e.g. transformers and inverters if it is possible to obtain some that are produced for another purpose produced for another propose. Therefore, these possibilities are also examined in the interviews.

This parameter is assessed on three-level scale, assessing the delivery time and the availability of required components and material. For this scope of technology catalogue, technologies with less delivery time are favored.

- Good: delivered within less than 13 weeks (for operation winter 2023/2024); **preferred**
- Medium: delivered within more than 13 and less than 65 weeks (for operation winter 2024/2025)
- Bad: delivered within 65 weeks or more for operation in more than two years

P7: Requirements for logistics and transportation infrastructure

War conditions affects the transportation infrastructure to a high extend, therefore technologies with less requirements for transportation infrastructure are highly valuable.

For transporting construction materials and project components, a domestic transportation infrastructure is needed, which may involve roads, railways, ships, etc. This infrastructure is essential for moving both imported and domestically sourced materials and components to power project sites.

This qualitative parameter is assessed on three-level scale, assessing the dependency on transportation infrastructure as:

- Good: low level of demands: the size and the weight of the modules / components of the technology make it possible to transport

on a normal size lorry; **preferred**

- Medium: medium level of demands. the size and the weight of the modules / components of the technology have a size and a weight that make it necessary to transport some of the components as special transport
- Bad: high level of demands. the size and the weight of the modules / components of the technology have a size and a weight that make it necessary to transport some of the components as special transport and or there is a need reinforcement of the roads or construction of new roads

P8: Technical installation time

The technical installation time is crucial because power capacity must be rapidly delivered to meet high winter demand.

The technical installation time includes the process of preparation of the building site, construct the plant and all processes until the technology is commissioned.

This qualitative parameter is assessed on three-level scale, assessing the timeframe for the installation of the technology:

- Good: Installation can happen on short-term which is less than 3 months; **preferred**
- Medium: Installation can happen on medium-term which is between 3 months 9 months
- Bad: Installation can happen on long-term which is more than 9 months Long-term

P9: Requirements for skilled staff in the construction and installation phase

The successful execution of energy projects depends on the availability of staff with the necessary skills and expertise.

A skilled workforce, such as experienced and qualified construction workers, engineers, project managers, environmental specialists, geologists, and safety professionals, could be more vital for some technologies than for others when it comes to the installation of energy projects.

The evaluation will rate the importance of the workforce for each technology.

This qualitative parameter is assessed on three-level scale, assessing the requirements for skilled staff in the construction phase as:

- Good: Require lower skilled staff in the construction phase (low); **preferred**
- Medium: Require medium skilled staff in the construction phase
- Bad: Require highly skilled staff (high)

P10: Grid balancing capacity

Effective grid balancing is critical for the reliability of the supply of electricity. Therefore, this quality is assessed in the evaluation.

The stability of the grids is exposed to sudden system disruptions caused by attacks on transmission lines and power plants.

Grid balancing capacity refers to the ability of a power system to adjust and stabilize electricity frequency, voltage, and reactive power within acceptable ranges. Furthermore, it should be able to ensure that the supply of electricity matches the demand of electricity at any moment. The qualities such as performing black start-ups and providing inertia are also taken into account in the evaluations.

The qualitative parameter is addressed on a three-level scale, assessing the technologies abilities to balance the grid.

- Good: high ability to balance the system, e.g. open cycle gas turbine power plants (OCGT), Wind power plants (WPPs), Hydro power plants (HPP), battery systems (BESS); **preferred**
- Medium: medium ability to balance the system e.g. TPPs with a high dynamic range, closed cycle gas turbine (CCGT)
- Bad: low ability to provide the fundamental balancing services to the grid system like TPPs with low flexibility and all inverter-based generation like PV, BESS, Wind Turbine. Most asynchronous generation do not contribute to the system inertia

P11: Requirements for electricity grid infrastructure

The requirements for the grid infrastructure that are critical for enabling the technology to operate are evaluated. This parameter evaluates the level of critical requirements related to the technology's ability to operate. Grid services that the technology can provide by itself will be taken into account when evaluating.

The qualitative parameter is assessed on a three-level scale, which evaluates the technology's requirements for connecting to the electricity grid infrastructure.

- Good: Easy to connect, **preferred**
- Medium: Moderate
- Bad: Challenging

P12: Requirements for skilled staff for operation and maintenance and special spare parts

In times of war, finding qualified personnel and specialized spare parts to operate and maintain energy production units can be challenging. Furthermore, it is a question of the possibility for relying on foreign workforce.

Specialized technicians and spare parts can be crucial for the ongoing maintenance of some energy systems. They conduct inspections, perform repairs, and ensure system reliability. The more specialized requirements for the O&M the higher risk for forced outage and longer periods of no production.

This qualitative parameter is assessed on three-level scale, assessing the requirements for skilled staff for operation and maintenance as:

- Good: do not require lower skilled staff during operation and maintenance and of specialized spare parts (low); **preferred**

- Medium: Require medium to highly skilled staff during operation and maintenance and of specialized spare parts, but the skilled staff and spare parts can be found in UA
- Bad: Require highly skilled staff (high) during operation and maintenance and of specialized spare parts, And the skilled staff and spare parts cannot be found in UA

P13: Possibility for camouflage and sheltering

Evaluation the properties of being able to camouflage and shelter is one way to assess how difficult it is to protect the technologies from attach and how easily it is for the enemy to identify the location of the technologies. Therefore, it is important properties for the resilience of operation in Ukraine in the current situation. Technologies that have a high potential for camouflaging and sheltering are preferred.

The evaluation only clarifies how easy it is to protect the technology by camouflaging or sheltering, e.g., by covering it with a lid of concrete or protecting it with an anti-drone net¹⁹. Therefore, the assessment is based on the physical configuration²⁰ of the technology. Thus, there is no evaluation of what types of attacks the different shelters can withstand.

The rating of the parameter is given based solely on assessment of the surface area and the height above ground of the technology, seen in relation to attacks. For example, for wind turbines, it is difficult to protect them from drone attacks at 100 m height, while technologies that is at ground level (or maybe even can be installed below ground level) could be easier to protect. Therefore, both the height and the size of surface area of the technologies and appurtenant components e.g., fuel storage is taken into account. Thus, for example biomass and coal plants and biogas engines fueled by gas

¹⁹ Anti-drone nets are devices that are used to capture and disable drones that are flying in restricted or unwanted areas. They are usually launched from guns, bazookas, or other drones, and they have weights or hooks that can entangle the rotors of the target drone.

²⁰ Physical configurations mean the surface area and the height above ground of the technology.

from a biogas plant receives lower rating than, than gas turbines and gas engines fueled by natural gas from the grid.

Chimneys are in this context similar to wind turbines, but they are less expensive to replace and less attractive to attack. Therefore, having a chimney does not necessarily mean a bad rating.

While the deployment of distributed energy generation units underground during wartime offers several advantages, it also presents challenges, including the cost of construction, maintenance, and the need for specialized expertise.

This qualitative parameter is assessed on three-level scale, assessing the potential for camouflage and sheltering of a specific technology as:

- Good: easy to shelter or camouflage the most essential parts or a part, e.g. has a surface area that is insignificant and do not need to be uncovered or to be installed over surface level, and the need for discharge of exhaust gases is limited; **preferred**
- Medium: possible to shelter or camouflage the most essential parts and do not have parts, which has a surface area that is significant but is not put 100% out of service

if only a small part of it is hit (e.g. biomass CHPs)

- Bad: not possible to shelter or camouflage the most essential parts (e.g. wind and PV) or a part, which has a surface area that is significant and that is put out of service if only a small part of it is hit(e.g. biogas plants)

P14: Risk associated with fuel supply

An essential consideration is the risk related to fuel, and potentially also spare parts supply, because of the challenging supply situation. Hence, technologies that require minimal on-going supplies after installation are preferred, such as renewable energy sources (wind, solar, water) that do not rely on fuel supply.

This parameter is assessed on three-level scale, assessing the risks associated with the fuel and spare part supply:

- Good: low risk associated, defined as no need for fuel (e.g. hydro, PV and Wind); **preferred**
- Medium: medium risk associated, defined as need for fuel that is local produced (e.g., biomass and biogas)
- Bad: high risk associated, defined as need for fuel that is not local produced e.g., natural gas and oil

APPENDIX B: LCOE CALCULATIONS

The calculation of the Levelized cost of electricity (LCOE), has been done by dividing the expenditures into the following categories, capital expenditure, operational expenditure, finance costs, fuel costs and CO2 costs.

Every category supplies the expenditures per unit nominal power. This expenditure has then been divided by the estimated

production, which is going to be supplied by that unit of nominal power, to obtain the LCOE.

The capital expenditure per MW power was supplied by the Danish technology catalogue. Specifically for the battery, it is assumed that the battery should be able to deliver 1 MW for 4 hours, when the battery is fully charged.

The operational expenditure was derived by accounting for the fixed and variable operation and maintenance costs for the given technology's entire lifetime. The whole fixed O&M was derived by multiplying the annual fixed O&M with the technology's estimated lifetime. Both values were obtained from the Danish technology catalogue. The whole variable O&M was calculated by taking the cost per unit power produced, which was supplied by the Danish technology catalogue and multiplying it with the estimated power production.

The estimated power production for wind turbines and photovoltaics, is described in the chapters that describe how the PV and WPP production for each Ukrainian region is mapped. For plants that rely on fuels, the expected full load hours are 3750 in the cold period and 5000 during the whole year. The battery is expected to charge 4 hours during low consumption hours and discharge 4 hours during high consumption hours.

The fuel costs have been calculated, by dividing the estimated power production with the name plate efficiency of each technology, which gives the fuel consumption, and then multiplying with the price of the fuel.

The nameplate efficiency of the technologies is provided in the data sheets and the fuel prices stem from the Socioeconomic Calculation Assumptions provided by the Danish Energy Agency. Specifically for the battery plant, it is expected that the plant will charge with power produced from coal plants, as cheaper power plants will be used for baseload and the battery will not be expected to charge from peak load power sources. Therefore, the power price for the battery is expected to be the same as the marginal price for coal.

The CO₂eq emission costs have been calculated, by multiplication of the emission per MWh consumed fuel by fuel type, the fuel consumption and the price per emission. The emission per MWh consumed fuel, originates from the Socioeconomic Calculation Assumptions provided by the Danish Energy Agency and the cost of emitted CO₂eq is set as 80€ per ton.

The finance cost is equivalent to what it would cost to finance the investment cost via a loan with an interest rate of 10% over 20 years or the full lifetime in case the full lifetime is shorter than 20 years.

APPENDIX C: CROSS CUTTING ISSUES

Grid stability related issues

Operational challenges in the UA grid system

The current operational challenges in the UA grid system are characterized by frequent alerts or even emergencies in several areas. When a system operates in islanding mode, it is practicing being more robust against infrastructure disturbances. These disturbances include:

- Missile/drone attack on grid substations, transmission, and distribution lines

- Dropout of large generation and demand facilities
- Lack of information exchange capability in some areas
- Limited or temporary capability for control and monitoring of the grid system.

Recommended power generation technologies must have the capability to function in grid operational scenarios with intentional islanding, operating in a more distributed and autonomous manner adding a better dynamic stability

to the individual grid islands. This is essential due to potential disruptions in communication and monitoring capabilities, including dropouts and extended periods of no data connection or data interrupting attacks from aggressive hackers. Therefore, robustness requirements for information security should be one of the highest priorities for new power generating systems, to secure the power supply even in isolated grid situations.

Challenges related to integration of renewable energy technologies.

To fully leverage the capabilities of variable renewable energy technologies, it is imperative that the operational strategies of the transmission system operator are specifically designed to manage the changes in the generation portfolio as well as the dynamics of the demand portfolio have changed over the years.

Taking into consideration the aforementioned information an interview was conducted with the transmission system operator “Ukrenergo”, which offered valuable insights into their current operational practices. Based on the interview it appears that the current practices are not favorable for the implementation of renewable energy. The following will outline how.

The present operational planning and dispatching procedures lack the flexibility required to accommodate changes in the operation of variable renewable energy (VRE) sources. In order to ensure the optimal integration of VRE sources, such as wind power, solar power, battery/energy storage systems and run of river hydro power it is essential to operate the system with maximum flexibility, as close to the time of production as possible.

Adjustments of the balancing time window must be reconsidered for creating the room for more optimal VRE integration. While conventional generation portfolios typically operate with an operational planning window of several days or even a week, portfolios with a significant amount of VRE often operate with a planning

window of less than an hour, sometimes as short as 5 or 15 minutes.

When addressing the necessity of flexibility, it is worth noting that a large amount of hydroelectric power plants (HPPs) with dams and pumped storage hydro (PHS) are already installed in Ukraine. HPPs and PHS are adding a large amount of flexibility to the UA energy system. HPPs and PHS are already used as storage systems for balancing and integrating variable renewable energy sources in parts of the Northern and Central European energy systems.

Another issue brought up in the interview is the practice of curtailing solar generation in September 2022, this suggests that an optimal dispatching based on least cost (economical dispatching) may not be currently applied.

The transition towards a more flexible power generating portfolio (more VRE) would require modernizing operational practices, e.g., to incorporate a better forecasting of VRE to ensure an efficient economical operation of the energy technologies.

Standardized and secured information exchange

To cope with the current and near future situations with more and more intensive interruptions from cyberattacks it is recommended to follow an international standardized digital approach (based on the IEC 61850, the IEC 61400-25 (wind and solar) series, the IEC 62351 series) when retrofitting, extending, or repairing damaged data communication systems applied in the electricity sector. Based on the coming EU Network Code for Cyber Security (NCCS) a series of coordinated activities on information exchange is recommended to be implemented as soon as possible.

The Network Code on Cybersecurity aims to set a European standard for the cybersecurity of cross-border electricity flows. It includes rules on cyber risk assessment, common

minimum requirements, cybersecurity certification of products and services, monitoring, reporting and crisis management. This Network Code provides a clear definition of the roles and responsibilities of the different stakeholders for each activity.

With the new Network Code in mind, robustness requirements for information security should be one of the highest priorities for implementing new power generating systems, to secure the supply in all system states and to support a strong cross border exchange of power with UA and all European interconnected countries.

Financial issues

Under the current situation there could be some special requirement related to the financing. In the interviews some stakeholders mentioned that it can be difficult and expensive to get projects financed in UA because the accepted repayment period is low and interest rates are high. Moreover, foreign investors such as IBRD (The International Bank for Reconstruction and Development and IFC (International Finance Cooperation) have stated that they are willing to invest during the war, however they will exclusively invest and provide loans to foreign companies because it is easier to insure any risks with foreign companies. Moreover, they expect support from the Ukrainian government

in creating a so-called Master Plan or General Plan and in developing the projects, along with an Insurance Fund that would cover military risks.

Transformers

Transformers are a critical component in the transmission and distribution of power. In the electrical supply the transformer changes the voltage of an alternating current. In power generation plants, such as gas turbines, diesel generators and wind turbines, the change of the voltage is essential to obtain the same voltage as that of the grid, to which the plants are connected. The voltage levels of the grid depend on specific designs, but typically the further that power is transmitted, the higher the voltage levels.

Furthermore, transformers are also used to step down the power levels, to stages until it matches the power level of the consumer.

Because transformers are needed to couple the plants with a specific electrical grid, transformers can become a limiting factor for the different power producing technologies.

Transformers come in many complexities and capacities. They can be supplied in modular forms or be tailor made to the given plant. The general categories are provided below.

Category	Apparent power rating	Weight	Description
Small transformers	<500 kVA	1kg – 2 tons	Transformers used in residential neighborhoods
Medium transformers – Distribution grids	500 kVA – 10 MVA	1-15 tons	Transformers used in substations – Step down
Medium transformers – Plants	1 MVA – 50 MVA	5-100 tons	Used for smaller plants – Step up
Large transformers	50 MVA <	70-400tons	Used for major substations and power generation plants -Step up

Table 37 : Transformers categories and their key parameters

The weight, shape and size can limit the use case for different transformers in Ukraine. Some cannot be transported across bridges due to their weight and some might have the wrong size to transport.

The weight and shape and size depends on whether the transformer is dry type or oil immersed, the oil immersed is anticipated to be most relevant in this context.

The delivery time of a transformer might pose a hinderance to the completion of a project, even though that gas turbines, diesel generators, wind turbines etc. are available, it might not be plausible to couple them to the grid, therefore the delivery time of the transformers needs to

be taken into consideration. The delivery time of large transformers is estimated to around 1-2 years whereas small transformers may be supplied within a couple of weeks.

Category	Time estimates for delivery
Small transformers	2 weeks
Medium transformers – Distribution grids	40 weeks
Medium transformers – Plants	20-28 weeks
Large transformers	1-2 years

Table 38: Estimated delivery time per transformer's category

APPENDIX D: METHODOLOGY FOR DETERMINING PV RESOURCE POTENTIALS IN UKRAINE

Calculation methods and assumptions for the charts

This section refers to the Figure 11 that shows the expected annual PV generation (MWh per MW installed capacity) in different regions of Ukraine. The maps are set up calculating the generalized power generation from photovoltaics, in the different Ukrainian regions, a raster map covering all of Ukraine from Global Solar Atlas was used. The raster map of Ukraine contains the yearly average potential production [kWh/kWp], covering the period between 1994-2018, given in a pixel containing the average value. Each raster pixel is given in a resolution corresponding to a measurement per approximately 650 m. The potential production average is based on the average theoretical production, which is based on solar

irradiance measured by geostationary satellites and the theoretical power production of a free-standing photovoltaic power plant, with stationary modules mounted at the optimal tilt in order for the modules to obtain a monthly maximum power production at the specific site.

Through Quantum Geographic Information System (QGIS), the values of the raster layer have been aggregated as an average for each Ukrainian region, so that the annual potential production average of photovoltaics [kWh/kWp] is given for each Ukrainian region.

This section refers to Figure 10 that shows the expected wintertime PV generation (MWh per MW installed capacity) in different regions of Ukraine. To calculate the average potential

production of photovoltaics in the winter period, October to March, multiple raster maps from Global Solar Atlas was used. These raster maps contained the daily potential production average from 1994-2018, for each of the corresponding months. Meaning that the daily values, was an average aggregate of the days in the corresponding month. Therefore, the daily values for each month, was calculated for each Ukrainian region and the average daily values for each Ukrainian region were multiplied by the number of days in the corresponding month and the summarized with the potential production of the other months in the cold period, where the monthly values were obtained in the same manner.

This calculation was also done for all of Ukraine, and the average power production of the photovoltaics in all of Ukraine, on an annual basis and during the cold period, was used as the estimated power consumption in the LCOE calculation.

As large photovoltaic power plants might be easily targeted by artillery and close-range ballistic missiles (CRBM), a buffer zone of 100km and 280km was applied from Russian controlled areas and Belarus, accounting for the longest range of Russian artillery and CRBMs. These two means of attack are considered, as the projectiles might be harder to intercept for the Ukrainian missile defense system.

APPENDIX E: METHODOLOGY FOR DETERMINING WIND RESOURCE POTENTIALS IN UKRAINE

To calculate the generalized power generation from wind turbines, in different Ukrainian regions, a raster map covering all of Ukraine was used. The raster map originated from Global Wind Atlas. The raster map contains the yearly capacity factor of wind turbines in the class IEC2²¹. This capacity factor has been derived through the calculation of power curves of IEC2 classes in relation to wind speeds that have been modelled through GWA version 3, which uses ERA5 datasets that has been supplied by the European Centre for Medium-Range Weather Forecasts. The ERA5 datasets are obtained through satellite measurements, that has been validated by radar measurements. The capacity factor is based on the average aggregate of the wind speeds between the

year 2008-2017. The capacity factor is given as a pixel containing a value, which has a resolution corresponding to the approximate distance of 200-250 meters between each measurement.

Through QGIS, the values of the raster layer have been aggregated as an average for each Ukrainian region, so that the annual capacity factor of the turbines in class IEC2 have been given for each Ukrainian region. Through the capacity factor the full load hours of the wind turbines was calculated, by using the wind turbine provided in the technology catalogue as a reference. The generating capacity for that wind turbine is 4,2MW, with a hub height of 85m and rotor diameter of 130m. The raster map, containing the

²¹ IEC Class 1 turbines are generally for wind speeds greater than 8 m/s. These turbines are tested for higher extreme wind speed and more severe turbulence.

IEC Class 2 turbines are designed for average wind speeds of 7.5 m/s to 8.5 m/s.

IEC Class 3 turbines are designed for winds less than 7.5 m/s. These turbines will need a larger rotor to capture the same amount of wind energy as a similar turbine at a Class II site. Source: <https://www.lmwindpower.com/en/stories-and-press/stories/learn-about-wind/what-is-a-wind-class>

capacity factor of IEC2 class turbines was used, as the wind turbine in the technology catalogue is a IEC2 class turbine, which means the wind profiles fit.

In order to calculate the full load hours of wind turbines in each Ukrainian region during the cold period, October to March, an hourly wind profile for 2019 from Renewables Ninja was assessed. It was concluded that 51% of the full load hours occurred during the cold period. This percentage was then used to calculate the full load hours for each region in Ukraine, during the cold period, by time multiplication for each region.

This calculation was also done for all of Ukraine, and the average power production of the wind turbines in all of Ukraine, on an annual basis and during the cold period, was used as the estimated power consumption in the LCOE calculation. As wind turbines might be easily targeted by artillery and CRBMs, a buffer zone of 100km and 280km was applied from Russian controlled areas and Belarus, accounting for the longest range of Russian artillery and CRBMs. These two means of attack are considered, as the projectiles might be harder to intercept for the Ukrainian missile defence system.

APPENDIX F: DATA SHEETS

Data sheets is attached in a excel sheet.

APPENDIX G: LOCAL CONSIDERATION

Local consideration for PV residential rooftop in Ukraine

In Ukraine, consumers can install electricity generation units for self-consumption without a license, if they do not supply excess energy to the Wholesale Electricity Market or other networks. They can also use energy storage systems without a license, provided they don't release stored energy into the Wholesale Electricity Market or other networks. Households with feed-in tariff agreement can sell their electricity to the universal service provider, while other consumers, including energy cooperatives, can sell to the off-taker (i.e., The Guaranteed Buyer).

In June 2023, Ukraine passed Law²² No 3220, introducing the concept of an active consumer (prosumer) and enabling them to qualify for the net billing support scheme. An active consumer status is achieved by signing electricity purchase and sale agreements under the self-generation mechanism, agreements with guaranteed buyers or universal service providers for selling electricity at a feed-in tariff, or by installing an energy storage system for participation in ancillary services and the purchase/sale of stored electricity. Under the net billing mechanism, if a household uses an energy storage system, electricity sales occur at the market price (e.g., 0.071 EUR/kWh in June 2023).

²² <https://zakon.rada.gov.ua/laws/show/3220-20#Text> : The Law of Ukraine regarding restoration and «green» transformation of the energy system of Ukraine.

Law No 3220 aims to encourage private households to install renewable energy generating units through self-generation mechanisms. To achieve this, a state target economic program was planned, but it hasn't been adopted by the Cabinet of Ministers as of October 2023. The program should motivate private households to install generating units up to 10 kW, along with energy storage systems at a ratio of 1 kW capacity to at least 0.5 kWh storage capacity. Stimulation measures for households could come in two forms: the feed-in tariff and the net billing system.

Local consideration for PV commercial, industrial, and public rooftop in Ukraine

In Ukraine, accompanying non-residential PV rooftop with battery storage, particularly for non-industrial purposes, is considered due to energy security measure. In the national level, Law 3220 has been enacted, focusing on net-billing and related issues. In the commercial and public sectors, this law is anticipated to encourage solar station installations by enabling surplus electricity feed-in and withdrawal as needed, potentially boosting the solar energy sector.

Once Law 3220 is enforced, the process of feeding surplus electricity from non-residential PV rooftop into the grid will require coordination. Unusual scenarios, such as multiple power lines for non-residential facilities like hospital complexes, where several buildings are connected to separate lines linked to the distribution system operator substation, may pose challenges. In such cases, transferring electricity between buildings without the involvement of the distribution system operator might not be feasible, necessitating the installation of a separate cable line. For example, if solar panels are installed on one building, and excess capacity is available to power nearby buildings, technical coordination with the distribution system operator may be necessary. In practical terms, facilities like hospitals and public buildings, which can only meet a portion of their electricity needs with

solar panels, may not find it beneficial to pursue a Feed-In Tariff arrangement. While using batteries for energy storage is desirable, the absence of economic incentives currently discourages their installation.

Amidst the war's impact on Ukraine's energy infrastructure, the EU has launched the "Ray of Hope" project, planning to donate 5,700 PV panels to the country. These panels will be primarily deployed in critical infrastructure sites such as hospitals, fire departments, and schools. Each site's installed capacity will not surpass 2 MW, contributing to energy resilience and support for vital services during these challenging times.

Local consideration for PV utility-scale in Ukraine

The government's current drive to encourage market participation encounters resistance from some companies due to market uncertainties, ongoing warfare, and price restrictions. These factors pose substantial barriers to investment in the renewable energy sector. To genuinely establish a sustainable renewable energy infrastructure and seamlessly integrate it into the power grid, comprehensive planning, well-defined mechanisms, long-term investment safeguards, and robust support mechanisms are essential. It's widely acknowledged that the predominant risk currently is the ongoing war, further emphasizing the importance of comprehensive insurance solutions. Addressing this risk requires collaborative efforts between the state and businesses.

According to the interviewed local experts, there are around 650 licensees for large-scale solar PV installation in Ukraine, with approx. 40 professional companies working in the field.

In Ukraine, the construction of utility-scale solar power installations can be accomplished relatively swiftly. The construction time for a turnkey 1 MW station is approximately three months, while a larger station with a capacity of 10-15 MW typically takes around five

months. For instance, the DTEK Pokrovska Solar Power Plant, which included 240 inverters and 320 panels, was successfully built in just nine months. The construction teams worked on-site, sometimes using robotic assistance, even during nighttime hours, with three different contractors involved in the project. This experience has enabled Ukrainians to develop both speed and quality in solar power construction, as they have learned from previous mistakes and continually improved their practices.

Large-scale solar installations offer a considerable advantage in terms of physical protection during military hostilities. These installations are distributed over extensive territories, making it highly impractical and costly to destroy them through direct attacks. In case of direct hits, only individual modules, such as 100 kW of panels, may require replacement, and the overall station can continue functioning. Potential issues might arise at the substations, which are now often containerized and can be easily installed and connected. Solar stations, as a technology, exhibit inherent resistance to warfare, and it is typically neither sensible nor economical to deploy air defense systems to protect solar farms.

Instances of solar station damage have primarily occurred in occupied territories or areas where direct military actions have taken place, such as tank movements or rocket strikes, or in areas where there were suspicions of hidden activity. Solar power technology has shown its resilience in the face of adversity. A 3.9 MW solar plant located in Ukraine's Kharkiv region, the largest utility-scale solar station in the area, was partially damaged during a Russian missile attack on May 28, 2022. Despite the damage to 416 solar panels and four inverters, the station was able to partly resume operations. The staff managed to disconnect the damaged components, allowing the plant to contribute 1.8 MW of clean electricity to the grid. This solar plant is situated 30 km south of Kharkiv and provides power to the city of Meref, serving as an example of distributed generation aimed at supplying energy

to a small town. The station features Talesun 325 W PV modules and 27 kW Fronius ECO 27.0-3-S string inverters, showcasing its capacity for resilience despite typical damage caused by rocket or projectile impacts in the region. The solar park's unique foundation on a swampy area using geo-screws allowed it to withstand local damage to supporting structures following the missile attack.



Figure 35: The Meref solar park in Kharkiv region partially damaged by Russian attacks. Photo by: Solar Generation



Figure 36: Solar Park in Kharkiv partially damaged by Russian attacks. Photo by: Solar Energy Association of Ukraine

According to local experts, the supply of equipment to Ukraine for solar power projects does not appear to be affected by the ongoing war. Equipment has been imported and transported by truckloads, even for larger installations up to 7 MW farms. Additionally, imports through Romania using Romanian ports have been utilized without significant issues. Solar power projects have been able to receive the necessary equipment from these sources and successfully build and connect their installations.

According to local experts, the construction of a solar station in Ukraine typically takes an average of 3-4 months. For a larger installation like a 5 MW station, it might take up to six months. In terms of project development speed, Ukraine is more efficient than Europe, although there are specific nuances that need to be addressed. However, due to the ongoing war and past issues with government commitment fulfilment, companies may face challenges in accessing financial resources.

Urgent technology catalogue for the Ukrainian power sector
January 2024 – version 1.2

This Technology catalogue is made with inputs from many Ukrainian experts and from experts from the following international and Danish organizations:

- MAN Energy Solutions
- RWE Scandinavia
- TOWII Renewables
- Better Energy
- Hybrid Greentech Energy Intelligence
- ABB – Hitachi
- Schneider Electric
- SGB Smit
- Siemens Energy
- BWSC

LIST OF ABBREVIATIONS

Abbreviations	Definitions
€	Euro
AC	Alternating current
BOS	Balance of System
LCOE	Levelized cost of electricity
CAPEX	Capital expenditure
CBRM	Close-range ballistic missiles
CCGT	Closed Cycle Gas generaTor
CHP	Combined heat and power
CO ₂	Carbon dioxide
DC	Direct current
EIA	Environmental impact assessment
ESCO	Energy service companies
ESS	Energy storage systems
EUR	Euro
FGT	Flue gas treatment
FLH	Full load hours
GW	Gigawatt
HPP	Hydro Power Plant
HPP	Hydroelectric Power Plant
HPP - PHS	Hydro Power Plant - Pump Hydro Storage
HPP - RoR	Hydro power Plant - Run of River
HVAC	Heating, ventilation, and air conditioning
IBRD	International Bank for Reconstruction and Development
IEC	International Electrotechnical Commission
IEV	International Electrical Vocabular (IEC standard)
IFC	International Finance Cooperation

Abbreviations	Definitions
kg	Kilogram
kW	Kilowatt
kWe	Kilowatt electric
kWh	Kilowatt-hour
LCOE	Levelized Cost of Electricity
LIB	Lithium-ion batteries
LTE	Life time extension
m	Meter
m ²	Square meter
MoE	Ministry of Energy
MW	Megawatt
MW _e	Megawatt electric
MWh	Megawatt-hour
MWp	Megawatt power
MWth	Megawatt thermal
NEURC	National Energy and Utilities Regulatory Commission (NEURC)
NG	Natural gas
NO _x	Nitrogen oxides
O&M	Operation and maintenance
OPEX	Operating expenses
ORC	Organic Rankine cycle
OCGT	Open Cycle Gas generaTor
P1, P2, etc.	Parameter 1, Parameter 2, etc.
PCED	Project and Cost Estimate Documentation
PHS	Pumped Hydro Storage
PJ	Petajoule
PPA	Power Purchase Agreement
PV	Photovoltaics
Q	Implementing speed (how quick this could be done)
R	The resilience of selected technologies
RoR	Run of River – hydro power plant
s	Second
SCR	Selective Catalytic Reduction
TEFS	Technical and Economic Feasibility Study
TMS	Thermal management system
TPP	Thermal Power Plant
TPP-G	Thermal Power Plant – gas fired
TPP-C	Thermal Power Plant- coal fired
TSO	Transmission system operator
UA	Ukraine, Ukrainian
UDEPP	Ukraine-Denmark Energy Partnership Programme
UNDP	United Nations Development Programme
UPS	Uninterruptible power supply
VRE	Variable energy resources

Abbreviations	Definitions
W	Watt
W	Winter impact
Wh	Watt-hour
WtE	Waste to Energy
WTG	Wind Turbine Generator
WTGS	Wind Turbine Generator System (IEV definition)